



**OPEN**

Industry Standard, Flexible Architecture

**GREEN**

Less Heat, Less Power Consumption

**STABLE**

Robust Design, Quality Parts

Stable and  
Reliable Solution

**Server/Workstation**

Motherboard

# X399D8A-2T

## User Manual

English

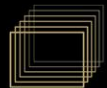

Version 1.0

Published July 2019

Copyright©2019 ASRock Rack Inc. All rights reserved.

## Copyright Notice:

No part of this documentation may be reproduced, transcribed, transmitted, or translated in any language, in any form or by any means, except duplication of documentation by the purchaser for backup purpose, without written consent of ASRock Rack Inc.

Products and corporate names appearing in this documentation may or may not be registered trademarks or copyrights of their respective companies, and are used only for identification or explanation and to the owners' benefit, without intent to infringe.

## Disclaimer:

Specifications and information contained in this documentation are furnished for informational use only and subject to change without notice, and should not be constructed as a commitment by ASRock Rack. ASRock Rack assumes no responsibility for any errors or omissions that may appear in this documentation.

With respect to the contents of this documentation, ASRock Rack does not provide warranty of any kind, either expressed or implied, including but not limited to the implied warranties or conditions of merchantability or fitness for a particular purpose.

In no event shall ASRock Rack, its directors, officers, employees, or agents be liable for any indirect, special, incidental, or consequential damages (including damages for loss of profits, loss of business, loss of data, interruption of business and the like), even if ASRock Rack has been advised of the possibility of such damages arising from any defect or error in the documentation or product.



This device complies with Part 15 of the FCC Rules. Operation is subject to the following two conditions:

- (1) this device may not cause harmful interference, and
- (2) this device must accept any interference received, including interference that may cause undesired operation.

## CALIFORNIA, USA ONLY

The Lithium battery adopted on this motherboard contains Perchlorate, a toxic substance controlled in Perchlorate Best Management Practices (BMP) regulations passed by the California Legislature. When you discard the Lithium battery in California, USA, please follow the related regulations in advance.

“Perchlorate Material-special handling may apply, see [www.dtsc.ca.gov/hazardouswaste/perchlorate](http://www.dtsc.ca.gov/hazardouswaste/perchlorate)”

**ASRock Rack's Website: [www.ASRockRack.com](http://www.ASRockRack.com)**

## Contact Information

If you need to contact ASRock Rack or want to know more about ASRock Rack, you're welcome to visit ASRock Rack's website at [www.ASRockRack.com](http://www.ASRockRack.com); or you may contact your dealer for further information.

### **ASRock Rack Incorporation**

6F., No.37, Sec. 2, Jhongyang S. Rd., Beitou District,

Taipei City 112, Taiwan (R.O.C.)

## Contents

<b>Chapter 1 Introduction</b>	<b>1</b>
1.1 Package Contents	1
1.2 Specifications	2
1.3 Unique Features	6
1.4 Motherboard Layout	7
1.5 Onboard LED Indicators	10
1.6 I/O Panel	11
1.7 Block Diagram	13
<b>Chapter 2 Installation</b>	<b>14</b>
2.1 Screw Holes	14
2.2 Pre-installation Precautions	15
2.3 Installing the CPU and Heatsink	16
2.4 Installing the CPU Cooler	20
2.5 Installation of Memory Modules (DIMM)	23
2.6 Expansion Slots (PCI Express Slots)	25
2.7 Jumper Setup	26
2.8 Onboard Headers and Connectors	28
2.9 Unit Identification purpose LED/Switch	35
2.10 Driver Installation Guide	35
2.11 M.2_SSD (NGFF) Module Installation Guide	36
<b>Chapter 3 UEFI Setup Utility</b>	<b>39</b>
3.1 Introduction	39
3.1.1 UEFI Menu Bar	39

3.1.2	Navigation Keys	40
3.2	Main Screen	41
3.3	OC Tweaker	42
3.4	Advanced Screen	49
3.4.1	CPU Configuration	50
3.4.2	Chipset Configuration	51
3.4.3	Storage Configuration	53
3.4.4	ACPI Configuration	54
3.4.5	Super IO Configuration	55
3.4.6	Serial Port Console Redirection	56
3.4.7	H/W Monitor	60
3.4.8	AMD CBS	62
3.4.9	AMD PBS	63
3.4.10	Instant Flash	64
3.5	Server Mgmt	65
3.5.1	System Event Log	66
3.5.2	BMC Network Configuration	67
3.6	Security	69
3.7	Boot Screen	70
3.7.1	CSM Parameters	72
3.8	Exit Screen	74
<b>Chapter 4 Software Support</b>		<b>75</b>
4.1	Install Operating System	75
4.2	Support CD Information	75

4.2.1	Running The Support CD	75
4.2.2	Drivers Menu	75
4.2.3	Utilities Menu	75
4.2.4	Contact Information	75
<b>Chapter 5 Troubleshooting</b>		<b>76</b>
5.1	Troubleshooting Procedures	76
5.2	Technical Support Procedures	78
5.3	Returning Merchandise for Service	78

# Chapter 1 Introduction

Thank you for purchasing ASRock Rack **X399D8A-2T** motherboard, a reliable motherboard produced under ASRock Rack's consistently stringent quality control. It delivers excellent performance with robust design conforming to ASRock Rack's commitment to quality and endurance.

In this manual, chapter 1 and 2 contains introduction of the motherboard and step-by-step guide to the hardware installation. Chapter 3 and 4 contains the configuration guide to BIOS setup and information of the Support CD.



*Because the motherboard specifications and the BIOS software might be updated, the content of this manual will be subject to change without notice. In case any modifications of this manual occur, the updated version will be available on ASRock Rack website without further notice. You may find the latest memory and CPU support lists on ASRock Rack website as well. ASRock Rack's Website: [www.ASRockRack.com](http://www.ASRockRack.com)*

*If you require technical support related to this motherboard, please visit our website for specific information about the model you are using.  
<http://www.asrockrack.com/support/>*

## 1.1 Package Contents

- ASRock Rack X399D8A-2T Motherboard  
(ATX Form Factor: 12.0-in x 9.6-in, 30.5 cm x 24.4 cm)
- Support CD
- Quick Installation Guide
- 1 x SATA3 Cable (60cm)
- 1 x Mini SAS HD to 4 SAS/SATA Cable (12G)
- 2 x Screws for M.2 Sockets
- 1 x I/O Shield



*If any items are missing or appear damaged, contact your authorized dealer.*

## 1.2 Specifications

<b>X399D8A-2T</b>	
<b>MB Physical Status</b>	
Form Factor	ATX
Dimension	12" x 9.6" (30.5 cm x 24.4 cm)
<b>Processor System</b>	
CPU	Supports AMD Ryzen™ Threadripper™ Processors
Socket	AMD Socket TR4 4094P
Chipset	AMD X399
<b>System Memory</b>	
Capacity	- 8 x 288-pin DDR4 DIMM slots - Supports up to 256GB DDR4 ECC U-DIMM
Type	- Quad Channel Memory Technology - Supports DDR4 ECC U-DIMM
Voltage	1.2V
DIMM Size per DIMM	ECC U-DIMM: 32GB, 16GB, 8GB, 4GB
DIMM Frequency	ECC / non-ECC U-DIMM: 3600+(OC)/3200(OC)/2933 (OC)/2666/2400/2133 MHz
<b>Expansion Slot</b>	
PCIe 3.0 x 16	SLOT2: Gen3 x16 link, auto switch to x8 link if Slot3 is occupied. SLOT3: Gen3 x8 link SLOT4: Gen3 x16 link, auto switch to x8 link if Slot5 is occupied. SLOT5: Gen3 x8 link SLOT6: Gen3 x16 link
PCIe 2.0 x 4 (open-ended)	SLOT7: Gen2 x 4 link
M.2	1x M-key (PCIe3.0 x4 or SATA 6Gb/s shared with SATA port) support 2230/2242/2260/2280/22110 1x M-key (PCIe3.0 x4) support 2230/2242/2260/2280/22110 ( Reserved BOM option for OCU Link)
<b>Storage</b>	
SATA Controller	8x SATA 6Gb/s; 2x SATA DOM, 4 via mini-SAS HD, 2x SATA 7-pin (one shared with M.2)
Additional SATA Controller	Asmedia 1061: 2 x SATA3 6.0 Gb/s (SATA3_6 / SATA3_7)
<b>Ethernet</b>	
Interface	10Gbps/1000 Mbps

LAN Controller	- 2 x RJ45 10GbE by Intel® X550-AT2 - Supports Wake-On-LAN - Supports Energy Efficient Ethernet 802.3az - Supports Dual LAN with Teaming function - Supports PXE - LAN1 Supports NCSI
<b>Management</b>	
BMC Controller	ASPEED AST2500 : IPMI (Intelligent Platform Management Interface) 2.0 with IChm and vMedia support
IPMI Dedicated GLAN	1 x Realtek RTL8211E for dedicated management
Features	NMI
<b>Graphics</b>	
Controller	ASPEED AST2500
VRAM	DDR4 16MB
<b>Audio</b>	
Audio code	Realtek ALC892
<b>Rear Panel I/O</b>	
PS/2 KB/mouse	1
VGA Port	1 x D-Sub
USB 3.1 Gen1 Port	2
USB 3.1 Gen2 Port	2 (1 type A, 1 type C)
LAN Port	- 2 x RJ45: 2x 10GbE by Intel® X550-AT2 - 1x IPMI dedicated LAN" - LAN Ports with LED (ACT/LINK LED and SPEED LED)
SPDIF	1
Audio	1(3 jack)
<b>Internal Connector</b>	
Auxiliary Panel Header	1 (includes chassis intrusion, location button & LED, system fault LED, and front LAN LED)
VGA header	1
COM header	1
SATA DOM	2
Speaker	1(4-pin)
TR1	1
TPM Header	1
IPMB Header	1
PMBus Header	1
BMC SMBus Header	1
Fan Header	6 x 4-pin Fans (1CPU/5 system)
ATX power	1x (24-pin) + 1x (8-pin) + 1x (8-pin)

Type A USB 3.1 Gen1 Port	1
USB 3.1 Gen1 Header	1 ( support 2 USB3.1 Gen1)
USB 2.0 Header	1 ( support 2 USB2.0)
ClearCMOS	1 (short pad)
NMI button	1
Front Panel	1
Buzzer	1
80 debug port LED	1
PWR_SMB	1
OH/FanFail LED	6 (Fan Fail LED only )
<b>System BIOS</b>	
BIOS Type	128Mb AMI UEFI Legal BIOS
BIOS Features	<ul style="list-style-type: none"> <li>- Plug and Play (PnP)</li> <li>- ACPI 2.0 Compliance Wake Up Events</li> <li>- SMBIOS 2.8 Support</li> <li>- ASRock Rack Instant Flash</li> </ul>
<b>Hardware Monitor</b>	
Temperature	<ul style="list-style-type: none"> <li>- CPU Temperature Sensing</li> <li>- System Temperature Sensing</li> <li>- Card side Temperature Sensing</li> <li>- System TR Temperature Sensing</li> </ul>
Fan	<ul style="list-style-type: none"> <li>- CPU/Rear/Front Fan Tachometer</li> <li>- CPU Quiet Fan (Allow Chassis Fan Speed Auto-Adjust by CPU Temperature)</li> <li>- CPU/Rear/Front Fan Multi-Speed Control</li> </ul>
Voltage	Voltage Monitoring: Vcore, VCCMAB, VCCMCD, 3v, 5v, 12v, 1.05V_PCH, +BAT, 3VSB, 5VSB, 5V_Dual, VcoreNB
<b>GPU Support</b>	
Technology	Supports AMD Quad-GPU CrossFireX™ Technology
<b>Support OS</b>	
OS	<p>Microsoft® Windows®</p> <ul style="list-style-type: none"> <li>- Windows 10 (64 bit)</li> </ul> <p>Linux®</p> <ul style="list-style-type: none"> <li>- RedHat Enterprise Linux Server 7.3 (64bit) / 7.6 (64bit)</li> <li>- CentOS 7.3 (64 bit) / 7.6 (64 bit)</li> <li>- Ubuntu 16.04 (64 bit) / 18.04 (64 bit)</li> </ul> <p>Virtual:</p> <ul style="list-style-type: none"> <li>- VMWare ESXi 6.5 u1</li> </ul> <p><i>* AMD RAID mode does not support Linux OS installation.</i>  <i>* Please refer to our website for the latest OS support list.</i></p>

**Environment****Temperature**

Operation temperature: 10°C ~ 35°C / Non operation temperature: -40°C ~ 70°C

*NOTE: Please refer to our website for the latest specifications.*



*This motherboard supports Wake from on Board LAN. To use this function, please make sure that the "Wake on Magic Packet from power off state" is enabled in Device Manager > Intel® Ethernet Connection > Power Management. And the "PCI Devices Power On" is enabled in UEFI SETUP UTILITY > Advanced > ACPI Configuration. After that, onboard LAN1&2 can wake up S5 under OS.*



*If you install Intel® LAN utility or Marvell SATA utility, this motherboard may fail Windows® Hardware Quality Lab (WHQL) certification tests. If you install the drivers only, it will pass the WHQL tests.*

---

## 1.3 Unique Features

ASRock Instant Flash is a BIOS flash utility embedded in Flash ROM. This convenient BIOS update tool allows you to update system BIOS without entering operating systems first like Windows®. With this utility, you can press the <F6> key during the POST or the <F2> key to enter into the BIOS setup menu to access ASRock Rack Instant Flash. Just launch this tool and save the new BIOS file to your USB flash drive, floppy disk or hard drive, then you can update your BIOS only in a few clicks without preparing an additional floppy diskette or other complicated flash utility. Please be noted that the USB flash drive or hard drive must use FAT32/16/12 file system.

# 1.4 Motherboard Layout

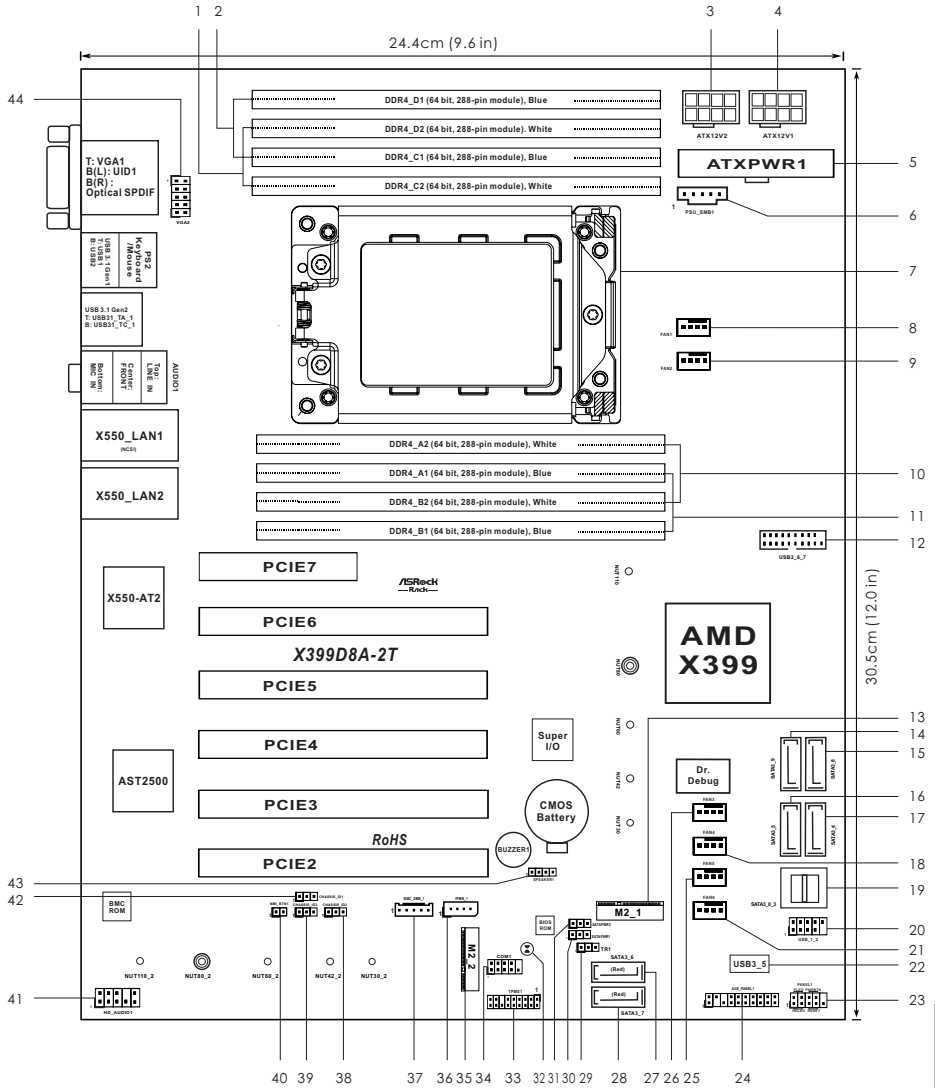

No.	Description
1	2 x 288-pin DDR4 DIMM Slots (DDR4_C2, DDR4_D2, White)
2	2 x 288-pin DDR4 DIMM Slots (DDR4_C1, DDR4_D1, Blue)
3	ATX 12V Power Connector (ATX12V2)
4	ATX 12V Power Connector (ATX12V1)
5	ATX Power Connector (ATXPWR1)
6	PSU SMBus (PSU_SMB1)
7	AMD Socket TR4 4094P
8	CPU Fan Connector (FAN1)
9	System Fan Connector (FAN2)
10	2 x 288-pin DDR4 DIMM Slots (DDR4_A2, DDR4_B2, White)
11	2 x 288-pin DDR4 DIMM Slots (DDR4_A1, DDR4_B1, Blue)
12	USB 3.1 Gen1 Header (USB3_6_7)
13	M.2 Socket (M2_1) (Type 2230/2242/2260/2280/22110)
14	SATA3 Connector (SATA3_9)
15	SATA3 Connector (SATA3_8)
16	SATA3 Connector (SATA3_5)
17	SATA3 Connector (SATA3_4)
18	System Fan Connector (FAN4)
19	MINI-SAS HD Connector (SATA3_0_3)
20	USB 2.0 Header (USB_1_2)
21	System Fan Connector (FAN6)
22	Vertical Type A USB 3.1 Gen1 (USB3_5)
23	System Panel Header (PANEL1)
24	Auxiliary Panel Header (AUX_PANEL1)
25	System Fan Connector (FAN5)
26	System Fan Connector (FAN3)
27	SATA3 DOM Connector (SATA3_6), Red
28	SATA3 DOM Connector (SATA3_7), Red
29	Thermal Sensor Header (TR1)
30	SATA DOM Power Jumper (SATAPWR1)
31	SATA DOM Power Jumper (SATAPWR2)
32	Clear CMOS Pad (CLRMOS1)
33	TPM Header (TPMS1)

No.	Description
34	COM Port Header (COM1)
35	M.2 Socket (M2_2) (Type 2230/2242/2260/2280/22110)
36	Intelligent Platform Management Bus header (IPMB_1)
37	BMC SMBus Header (BMC_SMB_1)
38	Chassis ID3 Jumper (CHASSIS_ID3)
39	Chassis ID2 Jumper (CHASSIS_ID2)
40	Non Maskable Interrupt Button (NMI_BTN1)
41	Front Panel Audio Header (HD_AUDIO1)
42	Chassis ID1 Jumper (CHASSIS_ID1)
43	Speaker Header (SPEAKER1)
44	Front VGA Header (VGA2)

*\*For DIMM installation and configuration instructions, please see p.22 (Installation of Memory Modules (DIMM)) for more details.*

## 1.5 Onboard LED Indicators

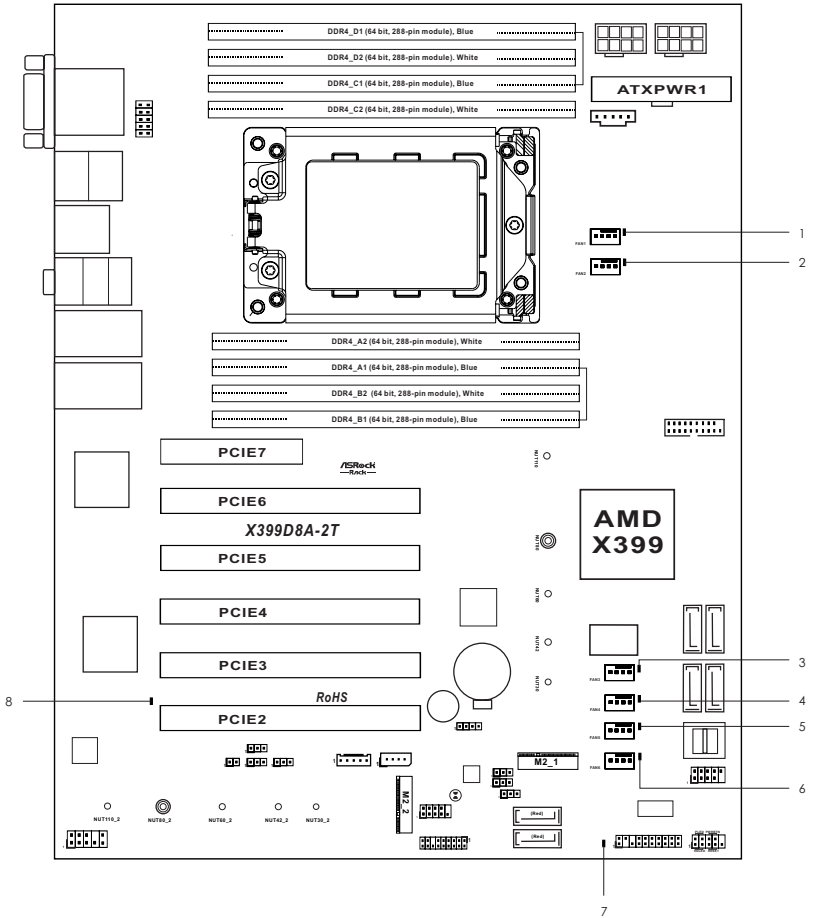

No.	Status	Description
1	Amber	FAN1 failed
2	Amber	FAN2 failed
3	Amber	FAN3 failed
4	Amber	FAN4 failed
5	Amber	FAN5 failed
6	Amber	FAN6 failed
7	Green	STB PWR ready
8	Green	BMC heartbeat LED

## 1.6 I/O Panel

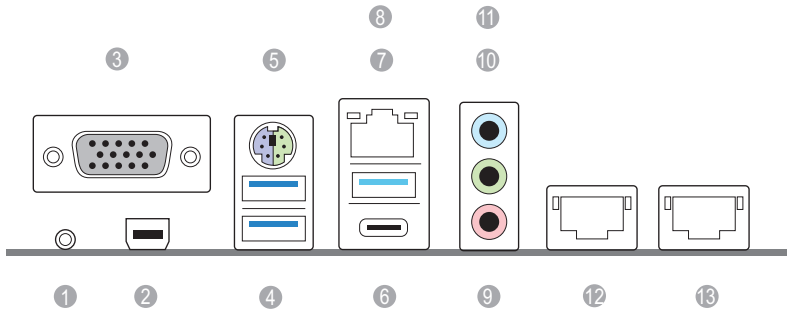

No.	Description	No.	Description
1	UID Switch (UID1)	8	LAN RJ-45 Port (IPMI_LAN)**
2	Optical SPDIF Out Port	9	Line In (Light Blue)
3	VGA Port (VGA1)	10	Front Speaker (Lime)
4	USB 3.1 Gen1 Ports (USB3_1_2)	11	Microphone (Pink)
5	PS/2 Mouse/Keyboard Port	12	LAN RJ-45 Port (LAN1)*
6	USB 3.1 Gen2 Port (USB31_TC_1)	13	LAN RJ-45 Port (LAN2)*
7	USB 3.1 Gen2 Port (USB31_TA_1)		

### LAN Port LED Indications

\*There are two LED next to the LAN port. Please refer to the table below for the LAN port LED indications.

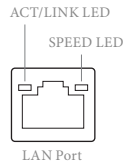

### Dedicated IPMI LAN Port LED Indications

Activity / Link LED		Speed LED	
Status	Description	Status	Description
Off	No Link	Off	10M bps connection or no link
Blinking Yellow	Data Activity	Yellow	100M bps connection
On	Link	Green	1G bps connection

\*\*There are two LEDs on each LAN port. Please refer to the table below for the LAN port LED indications.

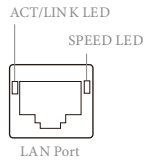

### 10G LAN Port (LAN1, LAN2) LED Indications

Activity / Link LED		Speed LED	
Status	Description	Status	Description
Off	No Link	Off	100Mbps connection or no link
Blinking Green	Data Activity	Yellow	1Gbps connection
On	Link	Green	10Gbps connection



# Chapter 2 Installation

This is an ATX form factor (12" x 9.6", 30.5 cm x 24.4 cm) motherboard. Before you install the motherboard, study the configuration of your chassis to ensure that the motherboard fits into it.



*Make sure to unplug the power cord before installing or removing the motherboard. Failure to do so may cause physical injuries to you and damages to motherboard components.*

## 2.1 Screw Holes

Place screws into the holes indicated by circles to secure the motherboard to the chassis.



*Attention! Before installing this motherboard, be sure to unscrew and remove the standoff at the marked location, under the motherboard, from the chassis, in order to avoid electrical short circuit and damage to your motherboard.*

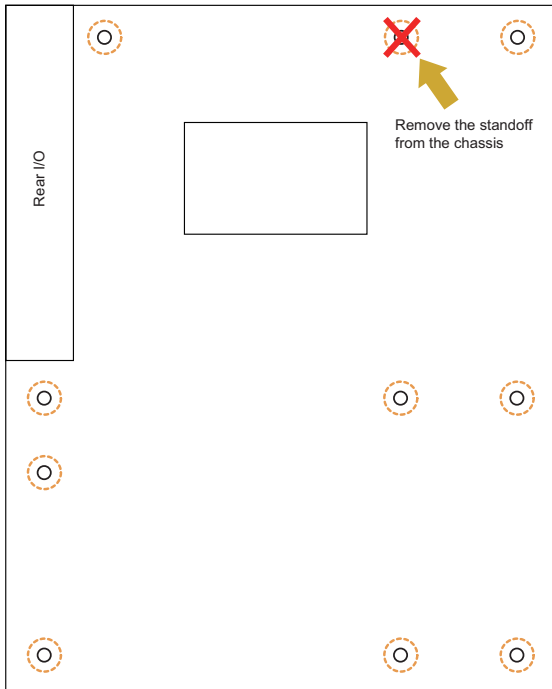

## 2.2 Pre-installation Precautions

Take note of the following precautions before you install motherboard components or change any motherboard settings.

1. Unplug the power cord from the wall socket before touching any components.
2. To avoid damaging the motherboard's components due to static electricity, NEVER place your motherboard directly on the carpet or the like. Also remember to use a grounded wrist strap or touch a safety grounded object before you handle the components.
3. Hold components by the edges and do not touch the ICs.
4. Whenever you uninstall any component, place it on a grounded anti-static pad or in the bag that comes with the component.
5. When placing screws into the screw holes to secure the motherboard to the chassis, please do not over-tighten the screws! Doing so may damage the motherboard.



*Do not over-tighten the screws! Doing so may damage the motherboard.*



*Before you install or remove any component, ensure that the power is switched off or the power cord is detached from the power supply. Failure to do so may cause severe damage to the motherboard, peripherals, and/or components.*

## 2.3 Installing the CPU and Heatsink



*Unplug all power cables before installing the CPU.*

1

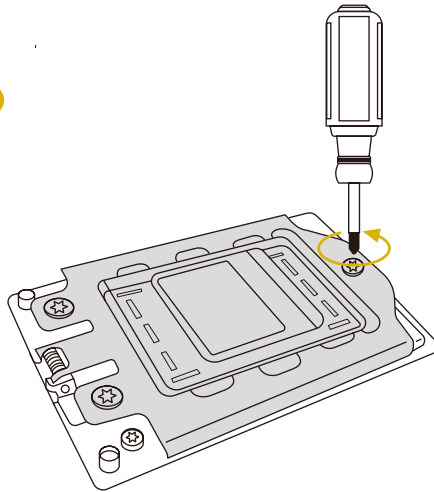

2

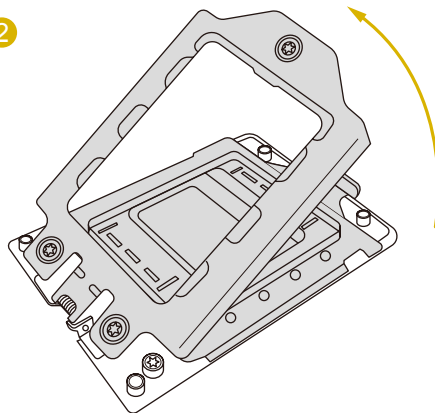

3

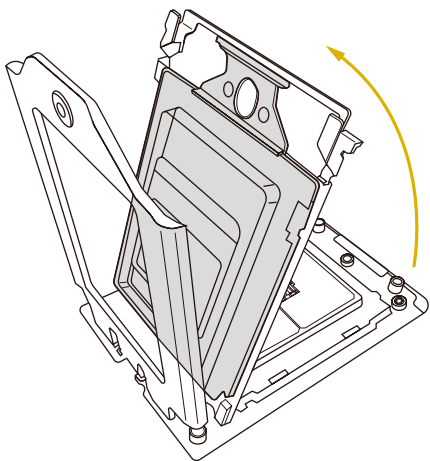

4

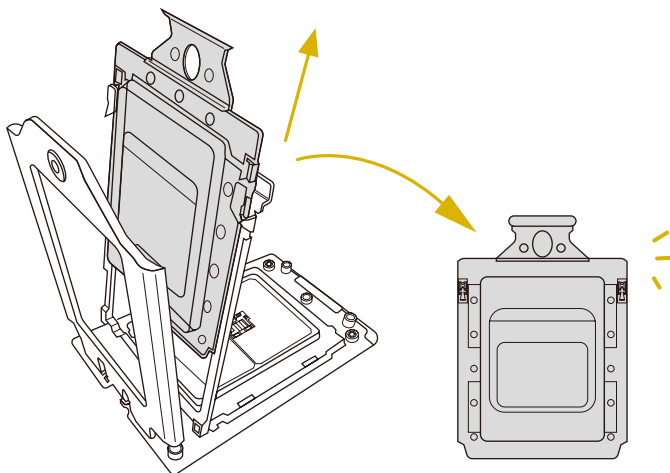

5

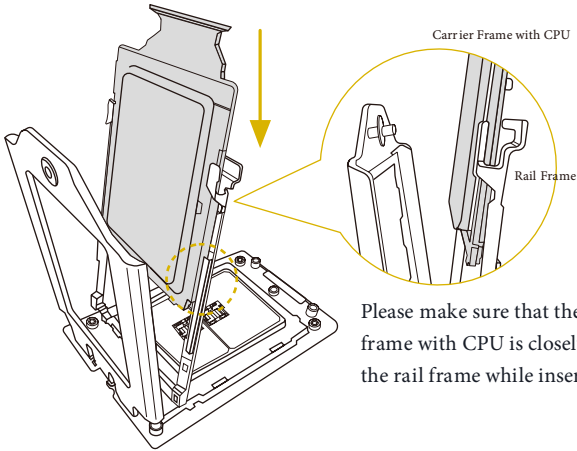

Install the orange carrier frame with CPU. Don't separate them.

6

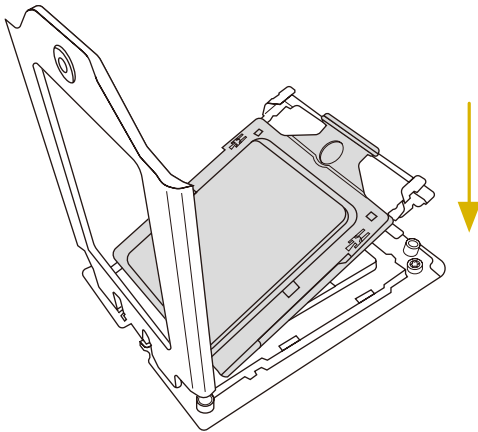

7

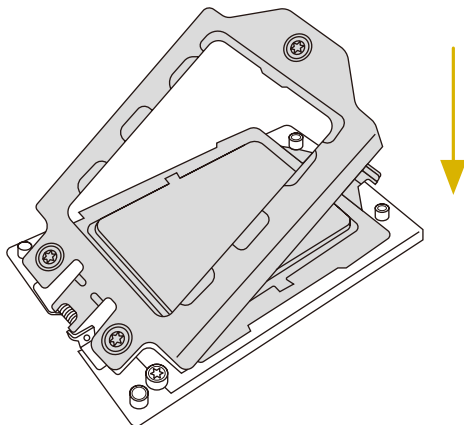

8

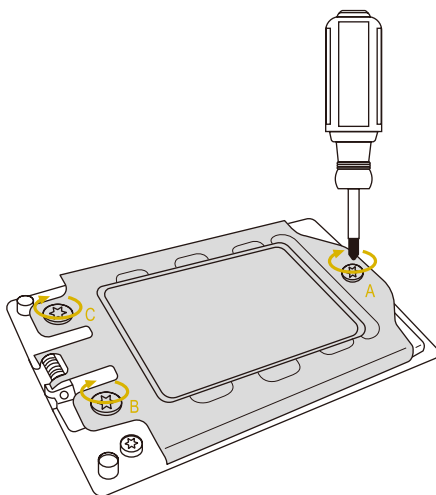

## 2.4 Installing the CPU Cooler

After you install the CPU into this motherboard, it is necessary to install a larger heatsink and cooling fan to dissipate heat. You also need to spray thermal grease between the CPU and the heatsink to improve heat dissipation. Make sure that the CPU and the heatsink are securely fastened and in good contact with each other.



*Please turn off the power or remove the power cord before changing a CPU or heatsink.*

1

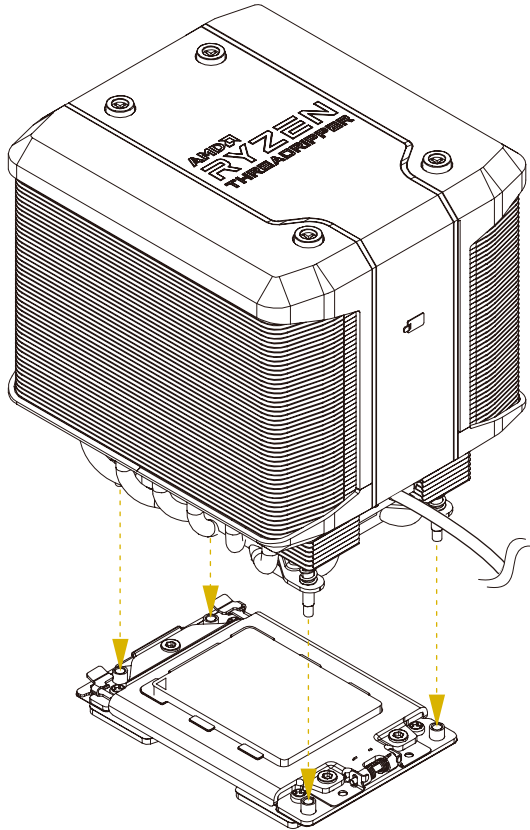

2

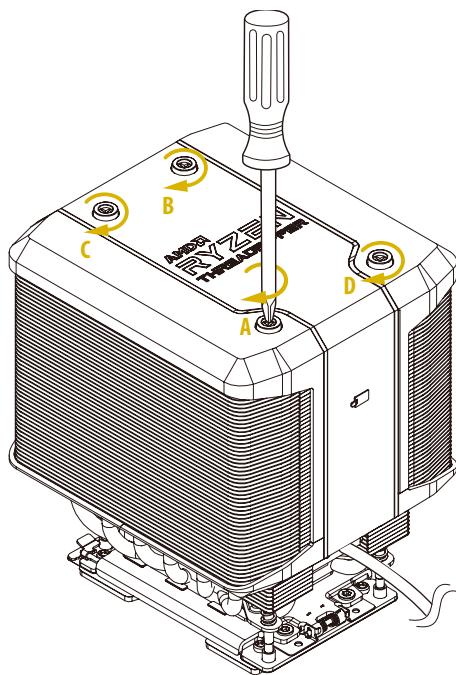

3

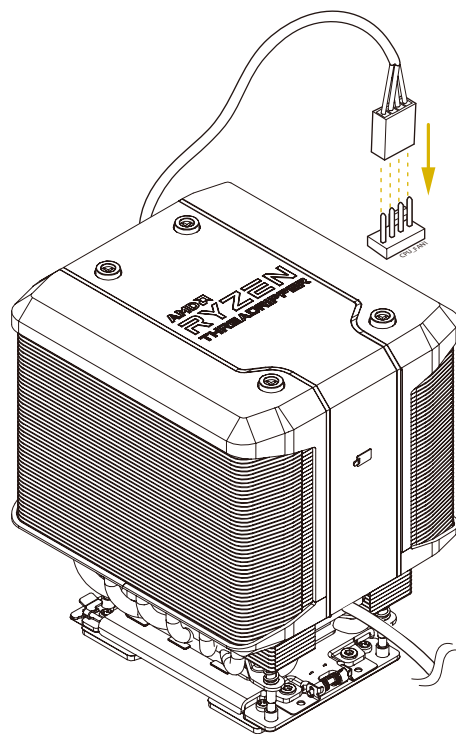

4

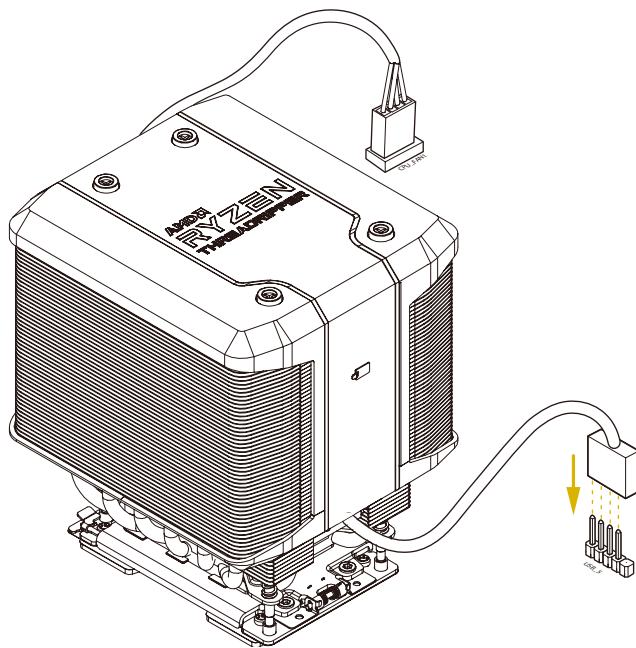

## 2.5 Installation of Memory Modules (DIMM)

This motherboard provides eight 288-pin DDR4 (Double Data Rate 4) DIMM slots in two groups, and supports Quad Channel Memory Technology.

A single memory module should be installed in the Blue socket.

	CPU1							
	A1	A2	B1	B2	C1	C2	D1	D2
1 DIMM	#							
2 DIMMS	#		#					
4 DIMMS	#		#		#		#	
8 DIMMS	#	#	#	#	#	#	#	#

### Dual Channel Memory Configuration

Priority	DDR4_A1	DDR4_B1	DDR4_C1	DDR4_D1
1	Populated	Populated		
2			Populated	Populated



1. It is not allowed to install a DDR, DDR2 or DDR3 memory module into a DDR4 slot; otherwise, this motherboard and DIMM may be damaged.
2. For dual channel configuration, you always need to install identical (the same brand, speed, size and chip-type) DDR4 DIMM pairs.
3. It is unable to activate Dual Channel Memory Technology with only one or three memory module installed.
4. Some DDR4 1GB double-sided DIMMs with 16 chips may not work on this motherboard. It is not recommended to install them on this motherboard.

1

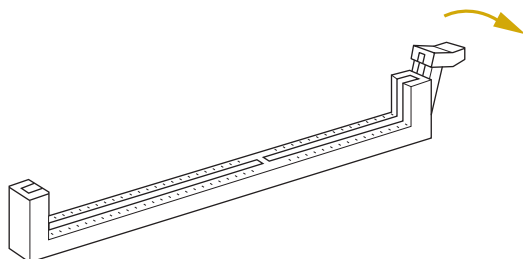

2

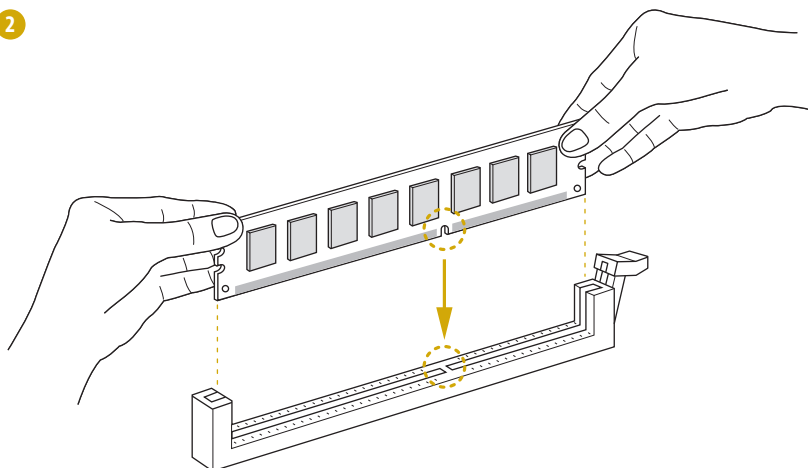

3

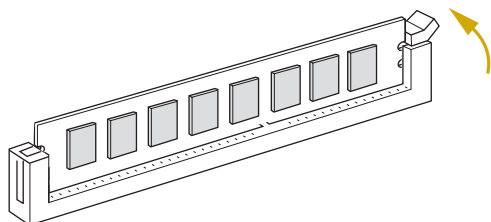

*The DIMM only fits in one correct orientation. It will cause permanent damage to the motherboard and the DIMM if you force the DIMM into the slot at incorrect orientation.*

## 2.6 Expansion Slots (PCI Express Slots)

There are 6 PCI Express slots on this motherboard.

### PCIe slot:

PCIe2, PCIe4 and PCIe6 (PCIe 3.0 x16 slot, from CPU) are used for PCI Express x16 lane width graphics cards.

PCIe3 and PCIe5 (PCIe 3.0 x16 slot, from CPU) are used for PCI Express x8 lane width graphics cards.

PCIe7 (PCIe 2.0 x4 slot, from PCH) is used for PCI Express x4 lane width graphics cards.

Slot	Generation	Mechanical	Electrical	Source
PCIe 2	3.0	x16	x16	CPU
PCIe 3	3.0	x16	x8	CPU
PCIe 4	3.0	x16	x16	CPU
PCIe 5	3.0	x16	x8	CPU
PCIe 6	3.0	x16	x16	CPU
PCIe 7	2.0	x4	x4	PCH

### PCI Express Slot Configuration

No.	PCIe 3	PCIe 2
Single Graphics Card		x16
Two Graphics Cards	x8	x8
No.	PCIe 5	PCIe 4
Single Graphics Card		x16
Two Graphics Cards	x8	x8

### Installing an expansion card

- Step 1. Before installing an expansion card, please make sure that the power supply is switched off or the power cord is unplugged. Please read the documentation of the expansion card and make necessary hardware settings for the card before you start the installation.
- Step 2. Remove the system unit cover (if your motherboard is already installed in a chassis).
- Step 3. Remove the bracket facing the slot that you intend to use. Keep the screws for later use.
- Step 4. Align the card connector with the slot and press firmly until the card is completely seated on the slot.
- Step 5. Fasten the card to the chassis with screws.
- Step 6. Replace the system cover.

## 2.7 Jumper Setup

The illustration shows how jumpers are setup. When the jumper cap is placed on the pins, the jumper is “Short”. If no jumper cap is placed on the pins, the jumper is “Open”. The illustration shows a 3-pin jumper whose pin1 and pin2 are “Short” when a jumper cap is placed on these 2 pins.

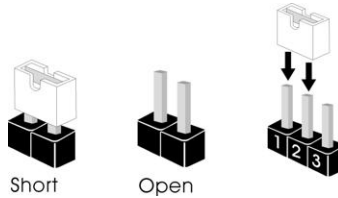

SATA DOM Power Jumper  
(3-pin SATAPWR1)  
(see p.7, No. 30)



SATA DOM (SATA\_6)  
requires 5V power supply



SATA DOM (SATA\_6) does  
NOT require 5V power supply  
(Default)

SATA DOM Power Jumper  
(3-pin SATAPWR2)  
(see p.7, No. 31)



SATA DOM (SATA\_7)  
requires 5V power supply



SATA DOM (SATA\_7) does  
NOT require 5V power supply  
(Default)



*Consult the documentation that comes with your SATA DOM and check whether or not Pin 7 requires 5V power supply.*

*If the connected SATA DOM requires 5V power supply, move the jumper caps placed on the SATA DOM Power Jumper (SATAPWR1/SATAPWR2) from pins 2-3 (default) to pins 1-2.*

*If the connected SATA DOM does NOT require 5V power supply, connect the SATA DOM power cable to the SATA DOM power header (SATAPWR1) and there is no need to change the default jumper setting of the SATA DOM Power Jumper (pins 2-3).*

**Warning!** *Incorrect setting of the SATA DOM Power Jumper (SATAPWR1/SATAPWR2) may cause damage to the motherboard or your SATA DOM.*

Chassis ID1 Jumper (3-pin CHASSIS_ID1) (see p.7, No. 42)	<b>1_2</b> 	<b>1_2</b> 
Chassis ID2 Jumper (3-pin CHASSIS_ID2) (see p.7, No. 39)	<b>1_2</b> 	<b>1_2</b> 
Chassis ID3 Jumper (3-pin CHASSIS_ID3) (see p.7, No. 38)	<b>1_2</b> 	<b>2_3</b> 
	Board Level SKU (Default)	Reserved for system level use

Chassis ID1 Jumper (3-pin CHASSIS_ID1) (see p.7, No. 42)	<b>1_2</b> 	<b>1_2</b> 
Chassis ID2 Jumper (3-pin CHASSIS_ID2) (see p.7, No. 39)	<b>2_3</b> 	<b>2_3</b> 
Chassis ID3 Jumper (3-pin CHASSIS_ID3) (see p.7, No. 38)	<b>2_3</b> 	<b>1_2</b> 
	Reserved for system level use	Reserved for system level use

Chassis ID1 Jumper (3-pin CHASSIS_ID1) (see p.7, No. 42)	<b>2_3</b> 	<b>2_3</b> 
Chassis ID2 Jumper (3-pin CHASSIS_ID2) (see p.7, No. 39)	<b>1_2</b> 	<b>1_2</b> 
Chassis ID3 Jumper (3-pin CHASSIS_ID3) (see p.7, No. 38)	<b>1_2</b> 	<b>2_3</b> 
	Reserved for system level use	Reserved for system level use

Chassis ID1 Jumper (3-pin CHASSIS_ID1) (see p.7, No. 42)	<b>2_3</b> 	<b>2_3</b> 
Chassis ID2 Jumper (3-pin CHASSIS_ID2) (see p.7, No. 39)	<b>2_3</b> 	<b>2_3</b> 
Chassis ID3 Jumper (3-pin CHASSIS_ID3) (see p.7, No. 38)	<b>1_2</b> 	<b>2_3</b> 
	Reserved for system level use	Reserved for system level use

## 2.8 Onboard Headers and Connectors



Onboard headers and connectors are NOT jumpers. Do NOT place jumper caps over these headers and connectors. Placing jumper caps over the headers and connectors will cause permanent damage to the motherboard.

System Panel Header  
(9-pin PANEL1)  
(see p.7, No. 23)

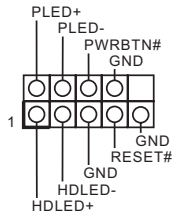

Connect the power switch, reset switch and system status indicator on the chassis to this header according to the pin assignments below. Note the positive and negative pins before connecting the cables.



**PWRBTN (Power Switch):**

Connect to the power switch on the chassis front panel. You may configure the way to turn off your system using the power switch.

**RESET (Reset Switch):**

Connect to the reset switch on the chassis front panel. Press the reset switch to restart the computer if the computer freezes and fails to perform a normal restart.

**PLED (System Power LED):**

Connect to the power status indicator on the chassis front panel. The LED is on when the system is operating. The LED keeps blinking when the system is in S1/S3 sleep state. The LED is off when the system is in S4 sleep state or powered off (S5).

**HDLED (Hard Drive Activity LED):**

Connect to the hard drive activity LED on the chassis front panel. The LED is on when the hard drive is reading or writing data.

The front panel design may differ by chassis. A front panel module mainly consists of power switch, reset switch, power LED, hard drive activity LED, speaker and etc. When connecting your chassis front panel module to this header, make sure the wire assignments and the pin assignments are matched correctly.

## Auxiliary Panel Header (18-pin AUX PANEL1) (see p.7, No. 24)

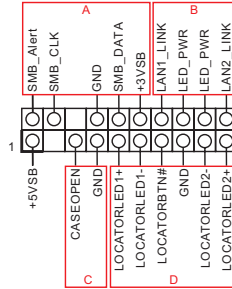

This header supports multiple functions on the front panel, including the front panel SMB, internet status indicator and chassis intrusion pin.



### A. Front panel SMBus connecting pin (6-1 pin FPSMB)

This header allows you to connect SMBus (System Management Bus) equipment. It can be used for communication between peripheral equipment in the system, which has slower transmission rates, and power management equipment.

### B. Internet status indicator (2-pin LAN1\_LED, LAN2\_LED)

These two 2-pin headers allow you to use the Gigabit internet indicator cable to connect to the LAN status indicator. When this indicator flickers, it means that the internet is properly connected.

### C. Chassis intrusion pin (2-pin CHASSIS)

This header is provided for host computer chassis with chassis intrusion detection designs. In addition, it must also work with external detection equipment, such as a chassis intrusion detection sensor or a microswitch. When this function is activated, if any chassis component movement occurs, the sensor will immediately detect it and send a signal to this header, and the system will then record this chassis intrusion event. The default setting is set to the CASEOPEN and GND pin; this function is off.

### D. Locator LED (6-pin LOCATOR)

This header is for the locator switch and LED on the front panel.

## Serial ATA3 Connectors

- (SATA3\_4)
- (see p.7, No. 17)
- (SATA3\_5)
- (see p.7, No. 16)
- (SATA3\_8)
- (see p.7, No. 15)
- (SATA3\_9)
- (see p.7, No. 14)



These four SATA3 connectors support SATA data cables for internal storage devices with up to 6.0 Gb/s data transfer rate.

Serial ATA3 DOM  
Connectors  
(SATA3\_6)  
(see p.7, No. 27)  
(SATA3\_7)  
(see p.7, No. 28)

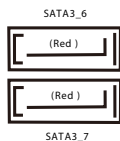

The SATA3 DOM connectors support both a SATA DOM (Disk-On-Module) and a SATA data cable for internal storage device.

Mini-SAS HD Connector  
(SATA3\_0\_3)  
(see p.7, No. 19)



The connector supports MiniSAS-to-SATA data cables for internal storage devices with up to 6.0 Gb/s data transfer rate.

USB 3.1 Gen1 Connector  
(USB3\_5)  
(see p.7, No. 22)



USB 2.0 Header  
(9-pin USB\_1\_2)  
(see p.7, No. 20)

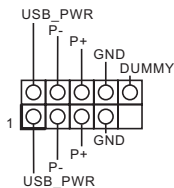

This is one header on this motherboard. Each USB 2.0 header can support two ports.

USB 3.1 Gen1 Header  
(19-pin USB3\_6\_7)  
(see p.7, No. 12)

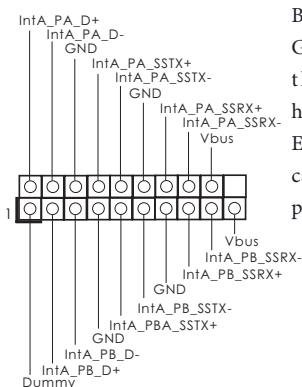

Besides two default USB 3.1 Gen1 ports on the I/O panel, there is one USB 3.1 Gen1 header on this motherboard. Each USB 3.1 Gen1 header can support two USB 3.1 Gen1 ports.

Front Panel Audio Header  
(9-pin HD\_AUDIO1)  
(see p.7, No. 41)

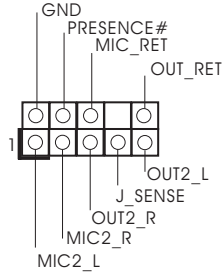

This is an interface for the front panel audio cable that allows convenient connection and control of audio devices.



1. High Definition Audio supports Jack Sensing, but the panel wire on the chassis must support HDA to function correctly. Please follow the instruction in our manual and chassis manual to install your system.

2. If you use AC'97 audio panel, please install it to the front panel audio header as below:

- A. Connect Mic\_IN (MIC) to MIC2\_L.
- B. Connect Audio\_R (RIN) to OUT2\_R and Audio\_L (LIN) to OUT2\_L.
- C. Connect Ground (GND) to Ground (GND).
- D. MIC\_RET and OUT\_RET are for HD audio panel only. You don't need to connect them for AC'97 audio panel.

Chassis Speaker Header  
(4-pin SPEAKER1)  
(see p.7, No. 43)

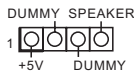

Please connect the chassis speaker to this header.

Baseboard Management  
Controller SMBus Header  
(5-pin BMC\_SMB\_1)  
(see p.7, No. 37)

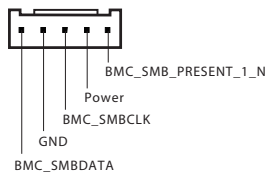

The header is used for the SM BUS devices.

---

### System Fan Connectors

(4-pin FAN2)

(see p.7, No. 9)

(4-pin FAN3)

(see p.7, No. 26)

(4-pin FAN4)

(see p.7, No. 18)

(4-pin FAN5)

(see p.7, No. 25)

(4-pin FAN6)

(see p.7, No. 21)

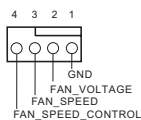

Please connect the fan cables to the fan connectors and match the black wire to the ground pin. All fans supports Fan Control.

---

### CPU Fan Connector

(4-pin FAN1)

(see p.7, No. 8)

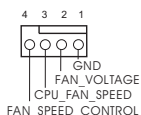

Please connect the CPU fan cable to the connector and match the black wire to the ground pin.

Though this motherboard provides a 4-Pin CPU fan (Quiet Fan) connector, 3-Pin CPU fans can still work successfully even without the fan speed control function. If you plan to connect a 3-Pin CPU fan to the CPU fan connector on this motherboard, please connect it to Pin 1-3.

*\*For more details, please refer to the Cooler QVL list on the ASRock Rack website.*

---

### ATX Power Connector

(24-pin ATXPWR1)

(see p.7, No. 5)

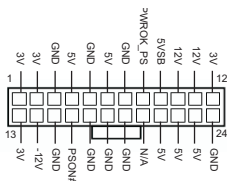

This motherboard provides a 24-pin ATX power connector. To use a 20-pin ATX power supply, please plug it along Pin 1 and Pin 13.

ATX 12V Power  
Connectors  
(8-pin ATX12V1)  
(see p.7, No. 4)  
(8-pin ATX12V2)  
(see p.7, No. 3)

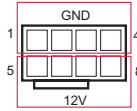

This motherboard provides two 8-pin ATX 12V power connectors.

TPM Header  
(17-pin TPMS1)  
(see p.7, No. 33)

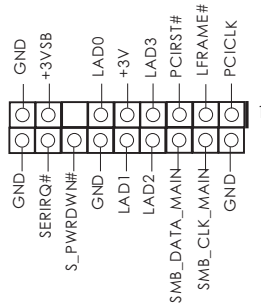

This connector supports Trusted Platform Module (TPM) system, which can securely store keys, digital certificates, passwords, and data. A TPM system also helps enhance network security, protects digital identities, and ensures platform integrity.

PSU SMBus  
(PSU\_SMB1)  
(see p.7, No. 6)

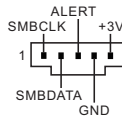

PSU SMBus monitors the status of the power supply, fan and system temperature.

Non Maskable Interrupt  
Button Header  
(NMI\_BTN1)  
(see p.7, No. 40)

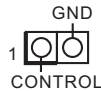

Please connect a NMI device to this header.

Intelligent Platform  
Management Bus header  
(4-pin IPMB\_1)  
(see p.7, No. 36)

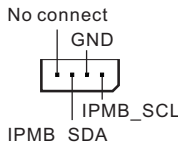

This 4-pin connector is used to provide a cabled base-board or front panel connection for value added features and 3rd-party add-in cards, such as Emergency Management cards, that provide management features using the IPMB.

---

Thermal Sensor Header  
(3-pin TR1)  
(see p.7, No. 29)

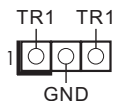

Please connect the thermal sensor cable to either pin 1-2 or pin 2-3 and the other end to the device which you wish to monitor its temperature.

---

Serial Port Header  
(9-pin COM1)  
(see p.7, No. 34)

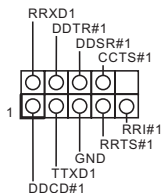

This COM header supports a serial port module.

---

Clear CMOS Pad  
(CLRMOS1)  
(see p.7, No. 32)



This allows you to clear the data in CMOS. To clear CMOS, take out the CMOS battery and short the Clear CMOS Pad.

---

Front VGA Header  
(10-pin VGA2)  
(see p.7, No. 44)

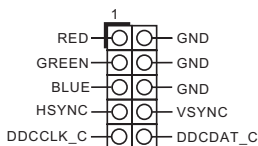

Please connect either end of VGA\_2X5 cable to VGA header.

## 2.9 Unit Identification purpose LED/Switch

With the UID button, You are able to locate the server you're working on from behind a rack of servers.

Unit Identification  
purpose LED/Switch  
(UID1)



When the UID button on the front or rear panel is pressed, the front/rear UID blue LED indicator will be turned on. Press the UID button again to turn off the indicator.

## 2.10 Driver Installation Guide

To install the drivers to your system, please insert the support CD to your optical drive first. Then, the drivers compatible to your system can be auto-detected and listed on the support CD driver page. Please follow the order from top to bottom to install those required drivers. Therefore, the drivers you install can work properly.

## 2.11 M.2\_SSD (NGFF) Module Installation Guide

The M.2, also known as the Next Generation Form Factor (NGFF), is a small size and versatile card edge connector that aims to replace mPCIe and mSATA. The M.2 Socket supports M.2 SATA3 6.0 Gb/s module and M.2 PCI Express module up to Gen3 x4 (16 Gb/s).

### Installing the M.2\_SSD (NGFF) Module

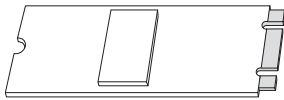

#### Step 1

Prepare a M.2\_SSD (NGFF) module and the screw.

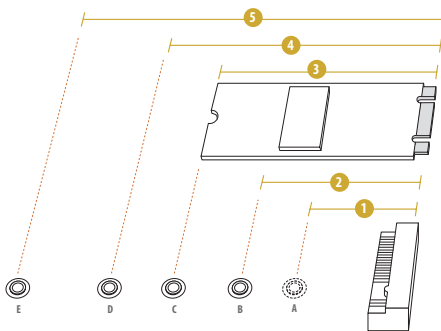

#### Step 2

Depending on the PCB type and length of your M.2\_SSD (NGFF) module, find the corresponding nut location to be used.

No.	1	2	3	4	5
Nut Location	A	B	C	D	E
PCB Length	3cm	4.2cm	6cm	8cm	11cm
Module Type	Type2230	Type 2242	Type2260	Type 2280	Type 22110

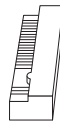
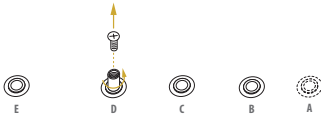
**Step 3**

Move the standoff based on the module type and length. The standoff is placed at the nut location E by default. Skip Step 3 and 4 and go straight to Step 5 if you are going to use the default nut. Otherwise, release the standoff by hand.

**Step 4**

Peel off the yellow protective film on the nut to be used. Hand tighten the standoff into the desired nut location on the motherboard.

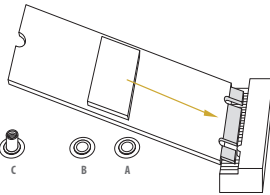
**Step 5**

Gently insert the M.2 (NGFF) SSD module into the M.2 slot. Please be aware that the M.2 (NGFF) SSD module only fits in one orientation.

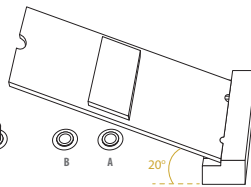
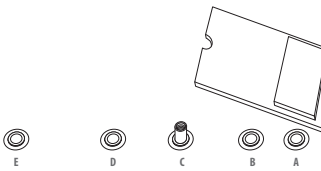

### Step 6

Tighten the screw with a screwdriver to secure the module into place.  
Please do not overtighten the screw as this might damage the module.

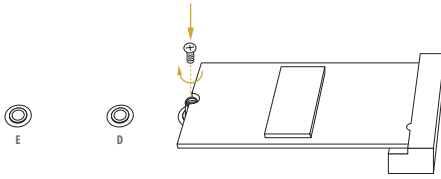

## Chapter 3 UEFI Setup Utility

### 3.1 Introduction

This section explains how to use the UEFI SETUP UTILITY to configure your system. The UEFI chip on the motherboard stores the UEFI SETUP UTILITY. You may run the UEFI SETUP UTILITY when you start up the computer. Please press <F2> or <Del> during the Power-On-Self-Test (POST) to enter the UEFI SETUP UTILITY; otherwise, POST will continue with its test routines.

If you wish to enter the UEFI SETUP UTILITY after POST, restart the system by pressing <Ctrl> + <Alt> + <Delete>, or by pressing the reset button on the system chassis. You may also restart by turning the system off and then back on.



*Because the UEFI software is constantly being updated, the following UEFI setup screens and descriptions are for reference purpose only, and they may not exactly match what you see on your screen.*

#### 3.1.1 UEFI Menu Bar

The top of the screen has a menu bar with the following selections:

Item	Description
Main	To set up the system time/date information
OC Tweaker	For overclocking configurations
Advanced	To set up the advanced UEFI features
Server Mgmt	To manage the server
Security	To set up the security features
Boot	To set up the default system device to locate and load the Operating System
Exit	To exit the current screen or the UEFI SETUP UTILITY

Use <←→> key or <→> key to choose among the selections on the menu bar, and then press <Enter> to get into the sub screen.

### 3.1.2 Navigation Keys

Please check the following table for the function description of each navigation key.

Navigation Key(s)	Function Description
← / →	Moves cursor left or right to select Screens
↑ / ↓	Moves cursor up or down to select items
+ / -	To change option for the selected items
<Tab>	Switch to next function
<Enter>	To bring up the selected screen
<PGUP>	Go to the previous page
<PGDN>	Go to the next page
<HOME>	Go to the top of the screen
<END>	Go to the bottom of the screen
<F1>	To display the General Help Screen
<F7>	Discard changes and exit the UEFI SETUP UTILITY
<F9>	Load optimal default values for all the settings
<F10>	Save changes and exit the UEFI SETUP UTILITY
<F12>	Print screen
<ESC>	Jump to the Exit Screen or exit the current screen

## 3.2 Main Screen

Once you enter the UEFI SETUP UTILITY, the Main screen will appear and display the system overview. The Main screen provides system overview information and allows you to set the system time and date.

```

Apilo Setup Utility - Copyright (C) 2019 American Megatrends, Inc.
Main | OC Tweaker | Advanced | Server Mgmt | Security | Boot | Exit

UEFI Version      : X399D8A-2T L1.01
BMC Version       : 1.00.00
Processor Type    : AMD Ryzen Threadripper 2920X 12-Core Processor

Processor Speed   : 3500MHz
Microcode Update  : 900F32/8008208
L1 Instruction Cache : 64KB
L1 Data Cache Size : 32KB
L2 Cache Size     : 512KB
L3 Cache per Socket : 32MB

DDR4_R1          : None
DDR4_R2          : None
DDR4_B1          : 4 GB(ECC DDR4-2400)
DDR4_B2          : None
DDR4_D1          : None
DDR4_D2          : None
DDR4_D1          : None
DDR4_D2          : None

Total Memory     : 4GB
Single-Channel Memory Mode

System Date      : [Mon 03/03/2019]
System Time     : [15:23:30]

Set the Date. Use Tab to switch between Date elements.
Default Ranges:
Year: 2005-2099
Months: 1-12
Days: dependent on month

F4: Select Screen
F1: Select Item
Enter: Select
F5: Change Option
F1: General Help
F7: Discard Changes
F9: Load UEFI Defaults
F10: Save and Exit
ESC: Exit

Version 2.20.1271. Copyright (C) 2019 American Megatrends, Inc.

```

## 3.3 OC Tweaker

In the OC Tweaker screen, you can set up overclocking features.

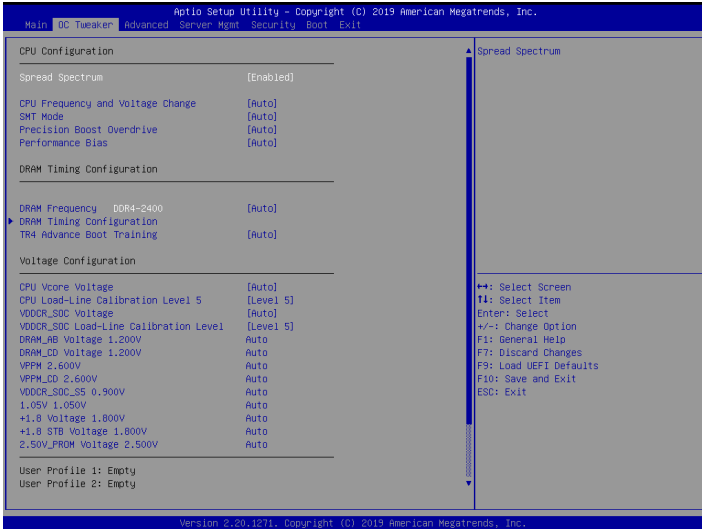

*Because the UEFI software is constantly being updated, the following UEFI setup screens and descriptions are for reference purpose only, and they may not exactly match what you see on your screen.*

### CPU Configuration

#### Spread Spectrum

Pcie Pll SSC percentage or Disable SSC. Range is 0.0%-1.9%(Enable is 0.5%). Last once is the POR for LBG.

#### CPU Frequency and Voltage Change

If Manual, multiplier and voltage will be set based on user selection. Final result is depending on CPU's capability.

#### SMT Mode

This item can be used to disable symmetric multithreading. To re-enable SMT, a POWER CYCLE is needed after selecting the 'Auto' option. WARNING - S3 is

NOT SUPPORTED on systems where SMT is disabled.

## Precision Boost Overdrive

Precision Boost Overdrive:

Disabled: Stock board values for standard IRM.

Enabled: Loads board limits for EDC, TDC and PPT.

Manual: Manual setting of PPT, TDC and EDC.

## Performance Bias

You can configure the settings of Performance Bias.

## DRAM Timing Configuration

### DRAM Frequency

If [Auto] is selected, the motherboard will detect the memory module(s) inserted and assign the appropriate frequency automatically.

### DRAM Timing Configuration

You can configure DRAM Timing.

### Primary Timing

#### CAS# Latency (tCL)

The time between sending a column address to the memory and the beginning of the data in response.

#### RAS# to CAS# Delay to Read (tRC)

The number of clock cycles required between the opening of a row of memory and accessing columns within it.

#### RAS# to CAS# Delay to Write (tRC)

The number of clock cycles required between the opening of a row of memory and accessing columns within it.

#### Row Precharge Time (tRP)

The number of clock cycles required between the issuing of the precharge command and opening the next row.

#### RAS# Active Time (tRAS)

The number of clock cycles required between a bank active command and issuing

the precharge command.

## Secondary Timing

### Fail Count

The number of training failure/retries required before boot from recovery mode.

### RAS# Cycle Time (tRC)

The number of memory clock cycles from and activate command to another activate command.

### RAS to RAS Delay (tRRD\_S)

The number of clock clocks between two rows activated in different banks of the same rank.

### RAS to RAS Delay (tRRD\_L)

The number of clock clocks between two rows activated in different banks of the same rank.

### Four Activate Window (tFAW)

The time window in which four activates are allowed the same rank.

### Write to Read Delay (tWTR\_S)

The number of clocks between the last valid write operation and the next read command to the same internal bank.

### Write to Read Delay (tWTR\_L)

The number of clocks between the last valid write operation and the next read command to the same internal bank.

### Write Recovery Time (tWR)

The amount of delay that must elapse after the completion of a valid write operation, before an active bank can be precharged.

### Trcpage (tMAW,MAC)

The minimum average time in memory clock cycles within a refresh window from an activate command to another activate command.

### TrdrdScL

The minimum number of cycles from the last clock of virtual CAS of the first read-burst operation to the clock in which CAS is asserted for a following read-burst operation in the same chipselect in the same bank group.

## TwrrwScL

The minimum number of cycles from the last clock of virtual CAS of the first write-burst operation to the clock in which CAS is asserted for a following write-burst operation in the same chipselect in the same bank group.

## Refresh Cycle Time (tRFC)

Configure the Refresh command period.

## Refresh Cycle Time 2 (tRFC2)

The x2 Fine Granularity Refresh mode Refresh command period.

## Refresh Cycle Time 4 (tRFC4)

The x4 Fine Granularity Refresh mode Refresh command period.

## CAS Write Latency (tCWL)

Configure CAS Write Latency.

## Read to Precharge (tRTP)

The number of clocks that are inserted between a read command to a row pre-charge command to the same rank.

## Trdwr

The minimum number of cycles from the last clock of virtual CAS of the first read-burst operation to the clock in which CAS is asserted for a following write-burst operation.

## Twrrd

The minimum number of cycles from the last clock of virtual CAS of the first write-burst operation to the clock in which CAS is asserted for a following write-burst operation.

## TwrrwSc

The minimum number of cycles from the last clock of virtual CAS of the first write-burst operation to the clock in which CAS is asserted for a following write-burst operation in the same chipselect.

## TwrrwSd

The minimum number of cycles from the last clock of virtual CAS of the first write-burst operation to the clock in which CAS is asserted for a following write-burst operation in the same DIMM.

## **TwrwrDd**

The minimum number of cycles from the last clock of virtual CAS of the first write-burst operation to the clock in which CAS is asserted for a following write-burst operation in a different DIMM.

## **TrdrdSc**

The minimum number of cycles from the last clock of virtual CAS of the first read-burst operation to the clock in which CAS is asserted for a following read-burst operation in the same chipselect.

## **TrdrdSd**

The minimum number of cycles from the last clock of virtual CAS of the first read-burst operation to the clock in which CAS is asserted for a following read-burst operation in the same DIMM.

## **TrdrdDd**

The minimum number of cycles from the last clock of virtual CAS of the first read-burst operation to the clock in which CAS is asserted for a following read-burst operation in a different DIMM.

## **tCKE**

Specifies the CKE minimum high and low pulse width in memory clock cycles.

## **ProcODT**

Specifies the Processor ODT.

## **Data Bus Configutaion**

Data Bus Configuration.

### **RttNom**

Configure RttNom

### **RttWr**

Configure RttWr

### **RttPark**

Configure RttPark

## **Command Rate (CR)#1**

Change Command Rate(CR) Setting.

## Gear Down Mode

Configure Gear Down Mode

## Power Down Enable

Enable or disable DDR4 power down mode.

## CAD Bus Configutaion

CAD Bus Configuration.

## CAD Bus Timing User Controls

Setup time on CAD bus signals to Auto or Manual.

## CAD Bus Drive Strength User Controls

Drive Strength on CAD bus signals to Auto or Manual.

## TR4 Advance Boot Training

Configure TR4 Advance Boot Training.

## Voltage Configuration

### CPU Vcore Voltage

Input voltage for the processor by the external voltage regulator.

### CPU Load-Line Calibration Level 5

FFSGUID:0951C12E-7D7E-49c9-93AA-593E8135904A

### VDDCR\_SOC Voltage

Input voltage for the processor by the external voltage regulator.

### VDDCR\_SOC Load-Line Calibration Level

VDDCR\_SOC Load-Line Calibration helps prevent VDDCR\_SOC voltage droop when the system is under heavy load.

### DRAM\_AB Voltage

Configure the voltage for the DRAM\_AB.

### DRAM\_CD Voltage

Configure the voltage for the DRAM\_AB.

## VPPM

Configure the voltage for the VPPM

## VPPM\_CD

Configure the voltage for the VPPM\_CD.

## VDDCR\_SOC\_S5

Configure the voltage for the VDDCR\_SOC\_S5.

## 1.05V

Configure the voltage for the 1.05V\_PROM Voltage.

## +1.8 Voltage

Configure the voltage for the +1.8 Voltage.

## +1.8 STB Voltage

Configure the voltage for the +1.8 STB Voltage.

## 2.50V\_PROM Voltage

Configure the voltage for the 2.50V\_PROM Voltage.

### 3.4 Advanced Screen

In this section, you may set the configurations for the following items: CPU Configuration, Chipset Configuration, Storage Configuration, ACPI Configuration, Super IO Configuration, Serial Port Console Redirection, H/W Monitor, AMD CBS, AMD PBS and Instant Flash.

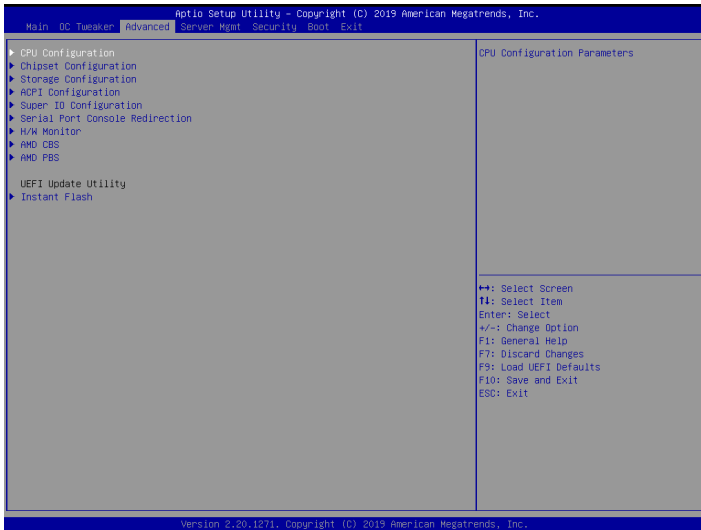

*Setting wrong values in this section may cause the system to malfunction.*

## 3.4.1 CPU Configuration

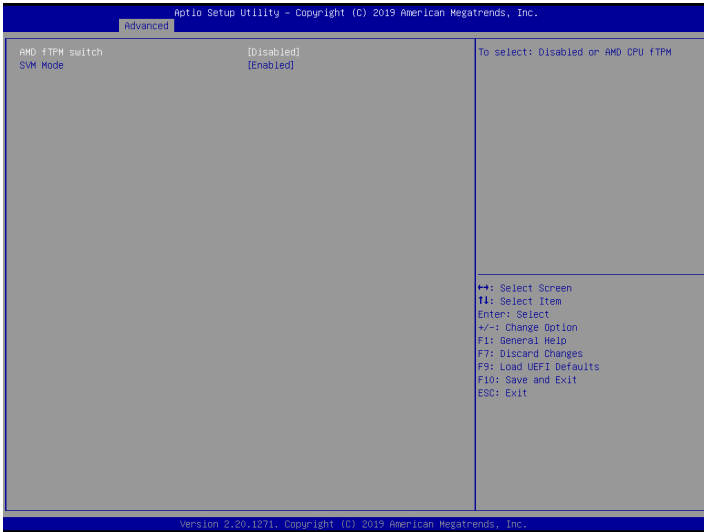

### AMD fTPM Switch

To select .0: Auto (Depend on Tcg module). 1: Disabled fTPM. 2: OnBoard SPI TPM2.0

### SVM Mode

Enable/disable CPU Virtualization.

## 3.4.2 Chipset Configuration

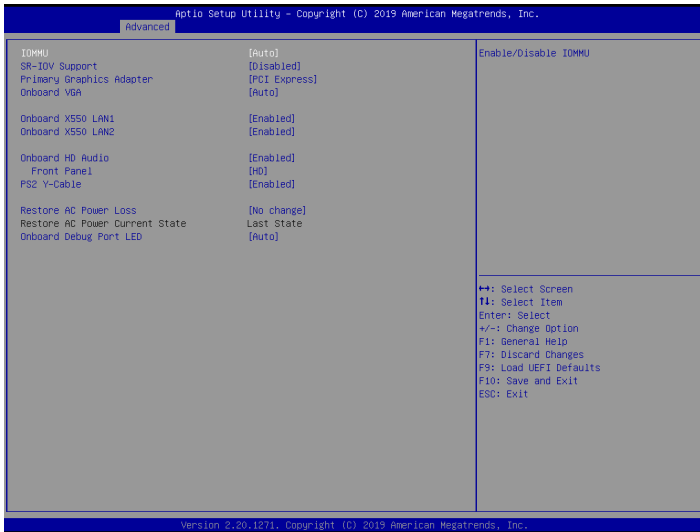

### IOMMU

To enable or disable IOMMU.

### SR-IOV Support

If system has SR-IOV capable PCIe Devices, this option Enables or Disables Single Root IO Virtualization Support.

### Primary Graphics Adapter

Select a primary VGA.

### Onboard VGA

To enable or disable Onboard VGA.

### Onboard X550 LAN1

To enable or disable Onboard LAN.

### Onboard X550 LAN2

To enable or disable Onboard LAN.

### Onboard HD Audio

Enable/disable onboard HD audio. Set to Auto to enable onboard HD audio and

automatically disable it when a sound card is installed.

### **Front Panel**

Use this item to select Front Panel Type.

### **PS2 Y-Cable**

Enable the PS2 Y-Cable or set this option to Auto.

### **Restore AC Power Loss**

This allows you to set the power state after a power failure. If [Power Off] is selected, the power will remain off when the power recovers. If [Power On] is selected, the system will start to boot up when the power recovers.

### **Restore AC Power Current State**

This allows you to restore AC Power Current State.

### **Onboard Debug Port LED**

Enable or disable the onboard Dr. Debug LED.

### 3.4.3 Storage Configuration

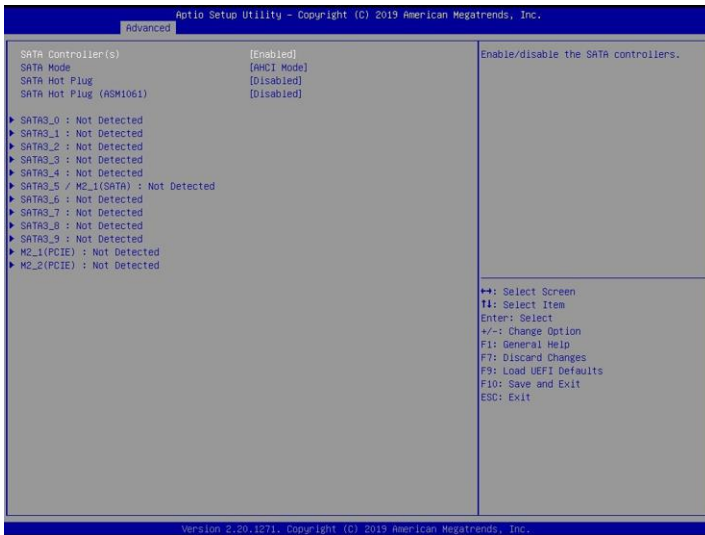

#### SATA Controller(s)

Use this item to enable or disable SATA Controllers.

#### SATA Mode

Identify the SATA port is connected to Solid State Drive or Hard Disk Drive.

Press <Ctrl+I> to enter RAID ROM during UEFI POST process.

#### SATA Hot Plug

Enable/disable the SATA Hot Plug Function.

#### SATA Hot Plug (ASM1601)

SATA Hot Plug (ASM1061 SATA\_8/9) Enable/Disable Control.

## 3.4.4 ACPI Configuration

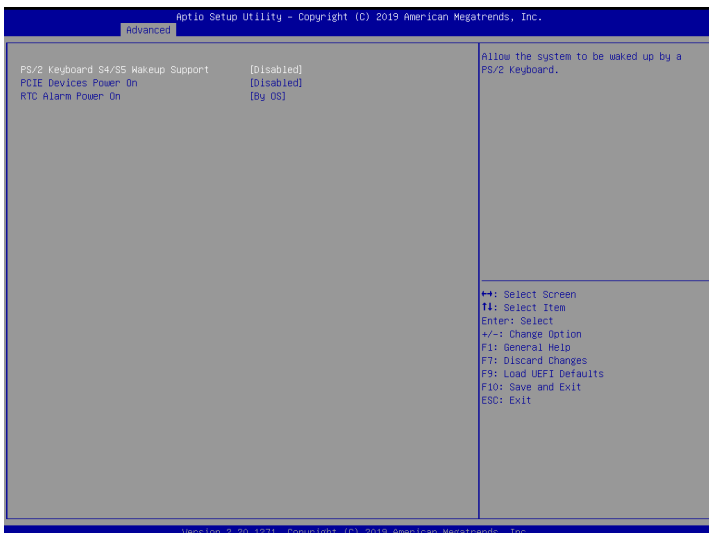

### PS/2 Keyboard S4/S5 Wakeup Support

Allow the system to be waked up by a PS/2 Keyboard.

### PCIe Devices Power On

Allow the system to be waked up by a PCIe device and enable wake on LAN.

### RTC Alarm Power On

Use this item to enable or disable RTC (Real Time Clock) to power on the system.

## 3.4.5 Super IO Configuration

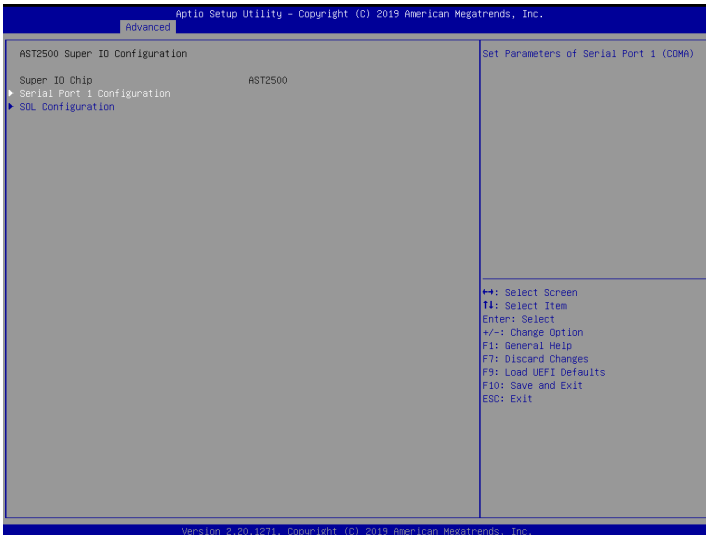

### Serial Port 1 Configuration

Use this item to set parameters of Serial Port 1 (COM1).

### Serial Port

Use this item to enable or disable the serial port.

### Serial Port Address

Use this item to select an optimal setting for Super IO device.

### SOL Configuration

Use this item to set parameters of SOL.

### SOL Port

Use this item to set parameters of SOL.

### Serial Port Address

Use this item to select an optimal setting for Super IO device.

## 3.4.6 Serial Port Console Redirection

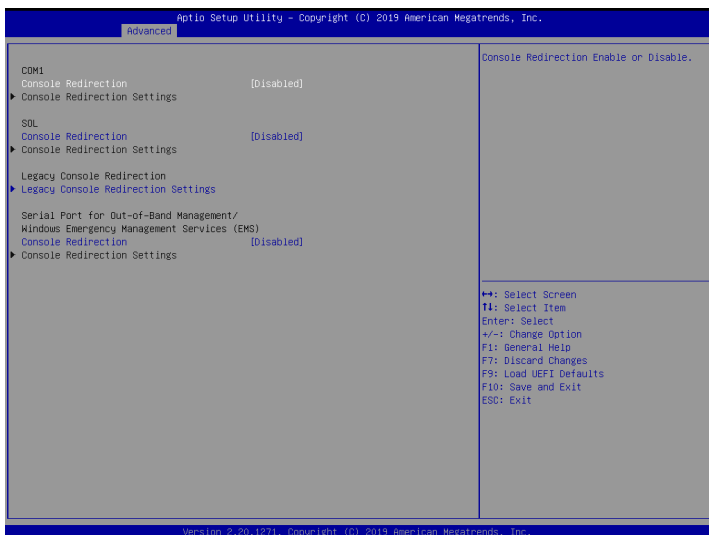

### COM1 / SOL

#### Console Redirection

Use this option to enable or disable Console Redirection. If this item is set to Enabled, you can select a COM Port to be used for Console Redirection.

#### Console Redirection Settings

Use this option to configure Console Redirection Settings, and specify how your computer and the host computer to which you are connected exchange information.

#### Terminal Type

Use this item to select the preferred terminal emulation type for out-of-band management. It is recommended to select [VT-UTF8].

Option	Description
VT100	ASCII character set
VT100+	Extended VT100 that supports color and function keys
VT-UTF8	UTF8 encoding is used to map Unicode chars onto 1 or more bytes
ANSI	Extended ASCII character set

**Bits Per Second**

Use this item to select the serial port transmission speed. The speed used in the host computer and the client computer must be the same. Long or noisy lines may require lower transmission speed. The options include [9600], [19200], [57600] and [115200].

**Data Bits**

Use this item to set the data transmission size. The options include [7] and [8] (Bits).

**Parity**

Use this item to select the parity bit. The options include [None], [Even], [Odd], [Mark] and [Space].

**Stop Bits**

The item indicates the end of a serial data packet. The standard setting is [1] Stop Bit. Select [2] Stop Bits for slower devices.

**Flow Control**

Use this item to set the flow control to prevent data loss from buffer overflow. When sending data, if the receiving buffers are full, a "stop" signal can be sent to stop the data flow. Once the buffers are empty, a "start" signal can be sent to restart the flow. Hardware flow uses two wires to send start/stop signals. The options include [None] and [Hardware RTS/CTS].

**VT-UTF8 Combo Key Support**

Use this item to enable or disable the VT-UTF8 Combo Key Support for ANSI/VT100 terminals.

**Recorder Mode**

Use this item to enable or disable Recorder Mode to capture terminal data and send it as text messages.

**Resolution 100x31**

Use this item to enable or disable extended terminal resolution support.

**Legacy OS Redirection Resolution**

Use this item to select the number of rows and columns used in legacy OS redirection.

**Putty Keypad**

Use this item to select Function Key and Keypad on Putty.

**Legacy Console Redirection****Legacy Console Redirection Settings**

Use this option to configure Legacy Console Redirection Settings, and specify how your computer and the host computer to which you are connected exchange information.

**Redirection COM Port**

Select a COM port to display redirection of Legacy OS and Legacy OPROM Messages.

## Resolution

On Legacy OS, the Number of Rows and Columns supported redirection.

## Redirect After POST

When Bootloader is selected, then Legacy Console Redirection is disabled before booting to legacy OS. When Always Enable is selected, then Legacy Console Redirection is enabled for legacy OS. Default setting for this option is set to Always Enable.

## Serial Port for Out-of-Band Management/Windows Emergency Management Services (EMS)

### Console Redirection

Use this option to enable or disable Console Redirection. If this item is set to Enabled, you can select a COM Port to be used for Console Redirection.

### Console Redirection Settings

Use this option to configure Console Redirection Settings, and specify how your computer and the host computer to which you are connected exchange information.

### Out-of-Band Mgmt Port

Microsoft Windows Emergency Management Services (EMS) allows for remote management of a Windows Server OS through a serial port.

### Terminal Type

Use this item to select the preferred terminal emulation type for out-of-band management. It is recommended to select [VT-UTF8].

Option	Description
VT100	ASCII character set
VT100+	Extended VT100 that supports color and function keys
VT-UTF8	UTF8 encoding is used to map Unicode chars onto 1 or more bytes
ANSI	Extended ASCII character set

### Bits Per Second

Use this item to select the serial port transmission speed. The speed used in the host computer and the client computer must be the same. Long or noisy lines may require lower transmission speed. The options include [9600], [19200], [57600] and [115200].

### Flow Control

Use this item to set the flow control to prevent data loss from buffer overflow. When sending data, if the receiving buffers are full, a "stop" signal can be sent to stop the data flow. Once the buffers are empty, a "start" signal can be sent to restart the flow. Hardware flow uses two wires to send start/stop signals. The options include [None], [Hardware RTS/CTS], and [Software Xon/Xoff].

**Data Bits**

**Parity**

**Stop Bits**

## 3.4.7 H/W Monitor

In this section, it allows you to monitor the status of the hardware on your system, including the parameters of the CPU temperature, motherboard temperature, CPU fan speed, chassis fan speed, and the critical voltage.

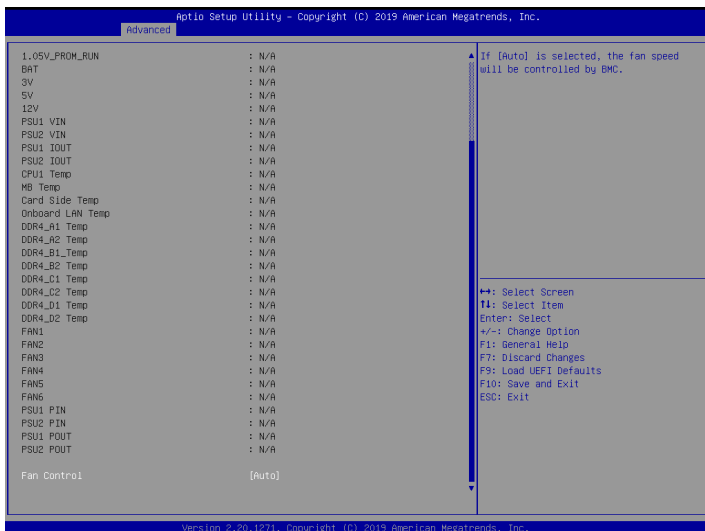

### Fan Control

If [Auto] is selected, the fan speed will controlled by BMC.

If [Manual] is selected, configure the items below.

#### FAN1

Fan Speed Control

#### FAN2

Fan Speed Control

#### FAN3

Fan Speed Control

#### FAN4

Fan Speed Control

#### FAN5

Fan Speed Control

## **FAN6**

Fan Speed Control

### **Smart Fan Control**

This allows you to set the Smart fan's level speed.

### **Smart Fan Duty Control**

Smart Fan Duty x (x means 1 to 11 stage)

This allows you to set duty cycle for each stage.

### **Smart Fan Temp Control**

Smart Fan Temp x (x means 1 to 11 stage)

This allows you to set temperature for each stage.

## 3.4.8 AMD CBS

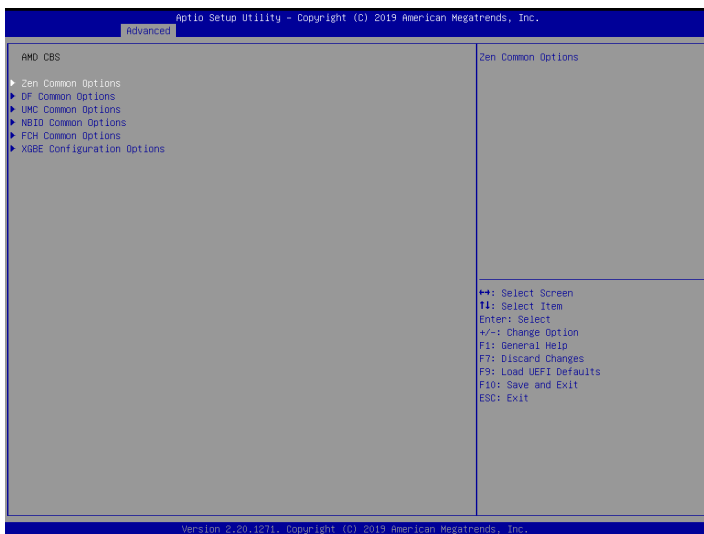

### Zen Common Options

Use this item to configure Zen Common options.

### DF Common Options

Use this item to configure DF Common options.

### UMC Common Options

Use this item to configure UMC Common options.

### NBIO Common Options

Use this item to configure NBIO Common options.

### FCH Common Options

Use this item to configure FCH Common options.

### XGBE Configuration Options

Use this item to configure XGBE Configuration options.

## 3.4.9 AMD PBS

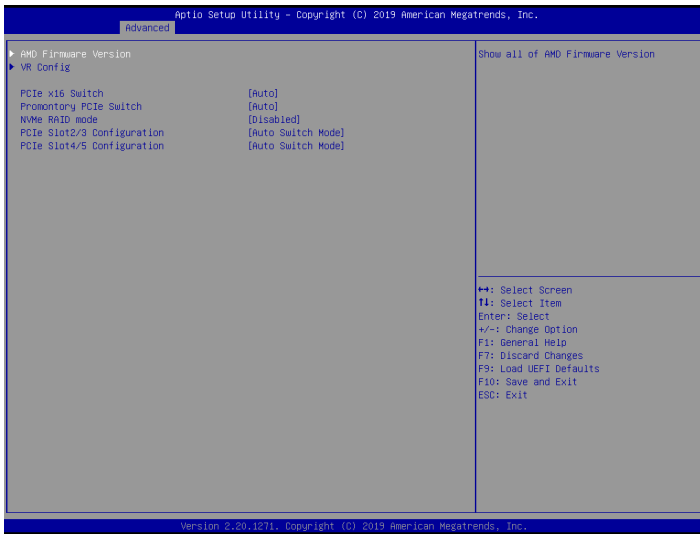

### AMD Firmware Version

Show all of AMD Firmware Version.

### VR Config

Show all of VR config files' version information.

### PCIe x16 Switch

Configure the PCIe x16 Switch.

### Promontory PCIe Switch

Configure the Promontory PCIe Switch.

### NVMe RAID mode

Configure the NVMe RAID mode.

### PCIe Slot2/3 Configuration

Configure the PCIe slots.

### PCIe Slot4/5 Configuration

Configure the PCIe slots.

## 3.4.10 Instant Flash

Instant Flash is a UEFI flash utility embedded in Flash ROM. This convenient UEFI update tool allows you to update system UEFI without entering operating systems first like MS-DOS or Windows. Just save the new UEFI file to your USB flash drive, floppy disk or hard drive and launch this tool, then you can update your UEFI only in a few clicks without preparing an additional floppy diskette or other complicated flash utility. Please be noted that the USB flash drive or hard drive must use FAT32/16/12 file system. If you execute Instant Flash utility, the utility will show the UEFI files and their respective information. Select the proper UEFI file to update your UEFI, and reboot your system after the UEFI update process is completed.

## 3.5 Server Mgmt

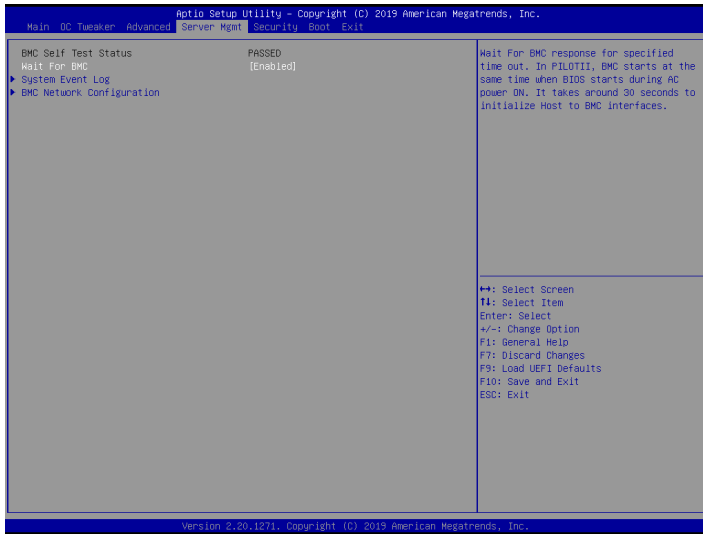

### Wait For BMC

Wait For BMC response for specified time out. BMC starts at the same time when BIOS starts during AC power ON. It takes around 90 seconds to initialize Host to BMC interfaces.

## 3.5.1 System Event Log

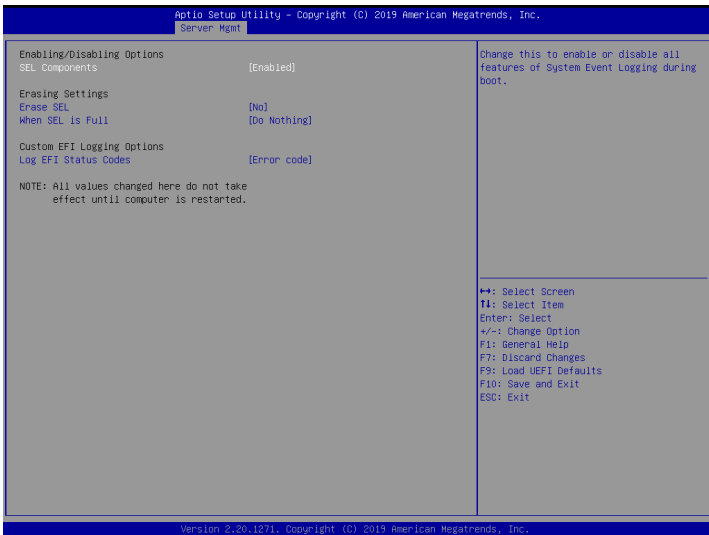

### SEL Components

Change this to enable or disable event logging for error/progress codes during boot.

### Erase SEL

Use this to choose options for erasing SEL.

### When SEL is Full

Use this to choose options for reactions to a full SEL.

### Log EFI Status Codes

Use this item to disable the logging of EFI Status Codes or log only error code or only progress code or both.

## 3.5.2 BMC Network Configuration

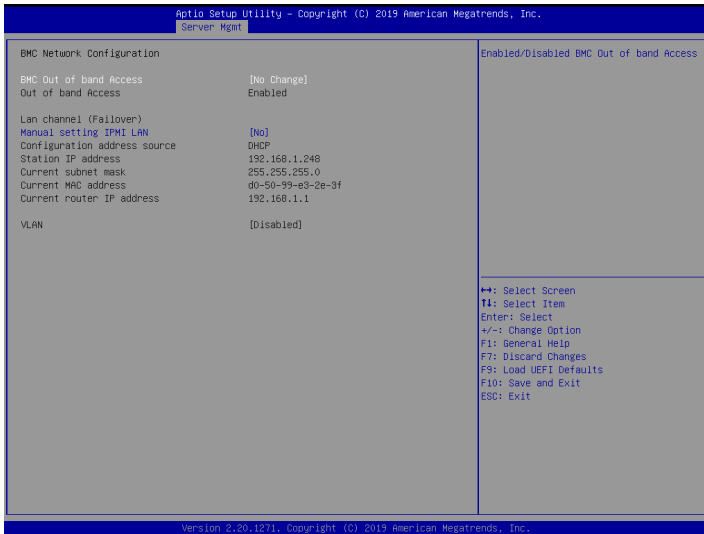

### BMC Out of Band Access

Enabled/Disabled BMC Out of band Access.

### Lan Channel (Failover)

### Manual Setting IPMI LAN

If [No] is selected, the IP address is assigned by DHCP. If you prefer using a static IP address, toggle to [Yes], and the changes take effect after the system reboots. The default value is [No].

### Configuration Address Source

Select to configure BMC network parameters statically or dynamically (by BIOS or BMC). Configuration options: [Static] and [DHCP].

**Static:** Manually enter the IP Address, Subnet Mask and Gateway Address in the BIOS for BMC LAN channel configuration.

**DHCP:** IP address, Subnet Mask and Gateway Address are automatically assigned by the network's DHCP server.



When [DHCP] or [Static] is selected, do NOT modify the BMC network settings on the IPMI web page.



*The default login information for the IPMI web interface is:*

*Username: admin*

*Password: admin*

*For more instructions on how to set up remote control environment and use the IPMI management platform, please refer to the IPMI Configuration User Guide or go to the Support website at: <http://www.asrockrack.com/support/faq.asp>*

## **VLAN**

Enabled/Disabled Virtual Local Area Network.

If [Enabled] is selected, configure the items below.

### **VLAN ID**

Use this item to configure VLAN ID setting.

### **VLAN Priority**

Use this item to configure VLAN Priority setting.

## 3.6 Security

In this section, you may set or change the supervisor/user password for the system. For the user password, you may also clear it.

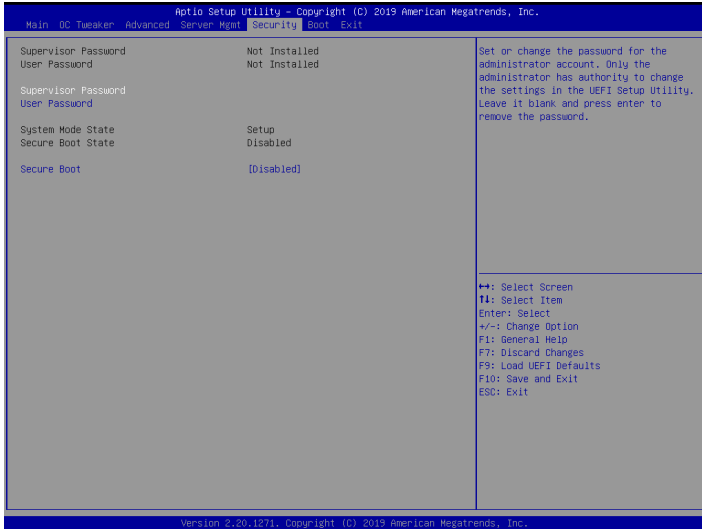

### Supervisor Password

Set or change the password for the administrator account. Only the administrator has authority to change the settings in the UEFI Setup Utility. Leave it blank and press enter to remove the password.

### User Password

Set or change the password for the user account. Users are unable to change the settings in the UEFI Setup Utility. Leave it blank and press enter to remove the password.

### Secure Boot

Use this to enable or disable Secure Boot Control. The default value is [Disabled]. Enable to support Windows Server 2012 R2 or later versions Secure Boot.

## 3.7 Boot Screen

In this section, it will display the available devices on your system for you to configure the boot settings and the boot priority.

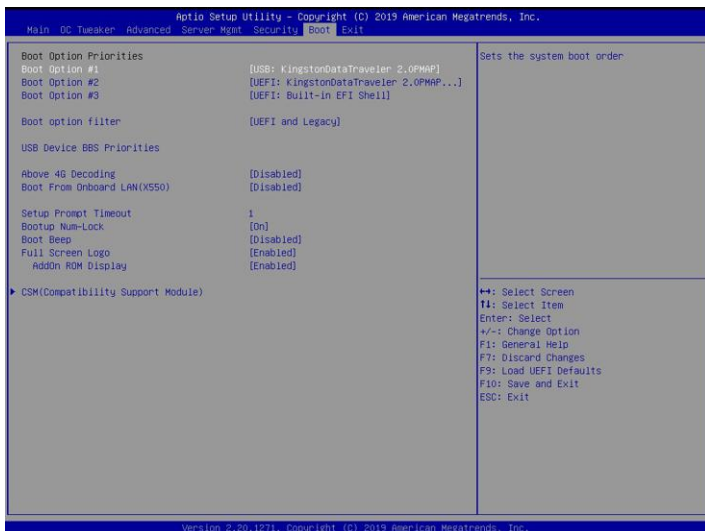

### Boot Option #1

Use this item to set the system boot order.

### Boot Option #2

Use this item to set the system boot order.

### Boot Option #3

Use this item to set the system boot order.

### Boot Option Filter

This option controls Legacy/UEFI ROMs priority.

### USB Device BBS Priorities

This page will show only when system install USB Storage.

### Above 4G Decoding

Enable or disable 64bit capable Devices to be decoded in Above 4G Address Space (only if the system supports 64 bit PCI decoding).

## Boot From Onboard LAN(X550)

Use this item to enable or disable the Boot From Onboard LAN feature.

## Setup Prompt Timeout

Configure the number of seconds to wait for the UEFI setup utility.

## Bootup Num-Lock

If this item is set to [On], it will automatically activate the Numeric Lock function after boot-up.

## Boot Beep

Select whether the Boot Beep should be turned on or off when the system boots up. Please note that a buzzer is needed.

## Full Screen Logo

Use this item to enable or disable OEM Logo. The default value is [Enabled].

## AddOn ROM Display

Use this option to adjust AddOn ROM Display. If you enable the option “Full Screen Logo” but you want to see the AddOn ROM information when the system boots, please select [Enabled]. Configuration options: [Enabled] and [Disabled]. The default value is [Enabled].

## 3.7.1 CSM Parameters

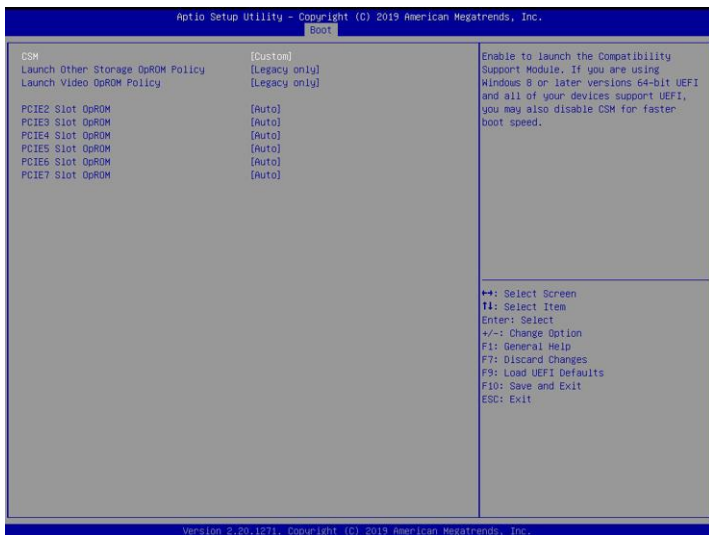

### CSM

Enable to launch the Compatibility Support Module. Please do not disable unless you're running a WHCK test. If you are using Windows Server 2012 R2 or later versions 64-bit UEFI and all of your devices support UEFI, you may also disable CSM for faster boot speed.

### Launch Other Storage OpROM Policy

Select UEFI only to run those that support UEFI option ROM only. Select Legacy only to run those that support legacy option ROM only. Select Do not launch to not execute both legacy and UEFI option ROM.

### Launch Video OpROM Policy

Select UEFI only to run those that support UEFI option ROM only. Select Legacy only to run those that support legacy option ROM only. Select Do not launch to not execute both legacy and UEFI option ROM.

### PCIEx Slot OpROM

To select Slot Storage and Network Option ROM policy. In Auto option, the default is Disabled with NVMe device, but it is Legacy with other devices. (This item can't select Video Option ROM policy.)

## PCIe3 Slot OpROM

To select Slot Storage and Network Option ROM policy. In Auto option, the default is Disabled with NVMe device, but it is Legacy with other devices. (This item can't select Video Option ROM policy.)

## PCIe4 Slot OpROM

To select Slot Storage and Network Option ROM policy. In Auto option, the default is Disabled with NVMe device, but it is Legacy with other devices. (This item can't select Video Option ROM policy.)

## PCIe5 Slot OpROM

To select Slot Storage and Network Option ROM policy. In Auto option, the default is Disabled with NVMe device, but it is Legacy with other devices. (This item can't select Video Option ROM policy.)

## PCIe6 Slot OpROM

To select Slot Storage and Network Option ROM policy. In Auto option, the default is Disabled with NVMe device, but it is Legacy with other devices. (This item can't select Video Option ROM policy.)

## PCIe7 Slot OpROM

To select Slot Storage and Network Option ROM policy. In Auto option, the default is Disabled with NVMe device, but it is Legacy with other devices. (This item can't select Video Option ROM policy.)

## 3.8 Exit Screen

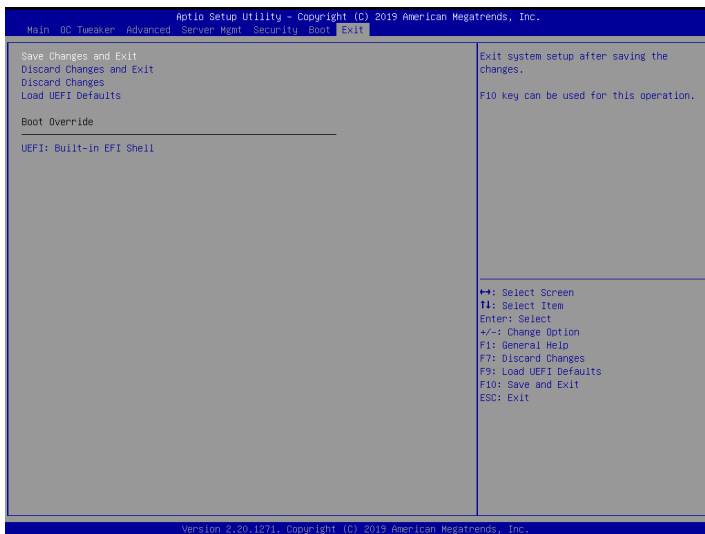

### Save Changes and Exit

When you select this option, the following message “Save configuration changes and exit setup?” will pop-out. Press <F10> key or select [Yes] to save the changes and exit the UEFI SETUP UTILITY.

### Discard Changes and Exit

When you select this option, the following message “Discard changes and exit setup?” will pop-out. Press <ESC> key or select [Yes] to exit the UEFI SETUP UTILITY without saving any changes.

### Discard Changes

When you select this option, the following message “Discard changes?” will pop-out. Press <F7> key or select [Yes] to discard all changes.

### Load UEFI Defaults

Load UEFI default values for all the setup questions. F9 key can be used for this operation.

# Chapter 4 Software Support

## 4.1 Install Operating System

This motherboard supports various Microsoft® Windows® / Linux compliant. Because motherboard settings and hardware options vary, use the setup procedures in this chapter for general reference only. Refer to your OS documentation for more information.

*\*Please download the Intel® SATA Floppy Image driver from the ASRock Rack's website ([www.asrockrack.com](http://www.asrockrack.com)) to your USB drive or simply install the SATA driver from the Support CD while installing OS in SATA RAID mode.*

## 4.2 Support CD Information

The Support CD that came with the motherboard contains necessary drivers and useful utilities that enhance the motherboard's features.

### 4.2.1 Running The Support CD

To begin using the support CD, insert the CD into your CD-ROM drive. The CD automatically displays the Main Menu if "AUTORUN" is enabled in your computer. If the Main Menu does not appear automatically, locate and double click on the file "ASRSetup.exe" from the root folder in the Support CD to display the menu.

### 4.2.2 Drivers Menu

The Drivers Menu shows the available device's drivers if the system detects installed devices. Please install the necessary drivers to activate the devices.

### 4.2.3 Utilities Menu

The Utilities Menu shows the application softwares that the motherboard supports. Click on a specific item then follow the installation wizard to install it.

### 4.2.4 Contact Information

If you need to contact ASRock Rack or want to know more about ASRock Rack, welcome to visit ASRock Rack's website at <http://www.ASRockRack.com>; or you may contact your dealer for further information.

# Chapter 5 Troubleshooting

## 5.1 Troubleshooting Procedures

Follow the procedures below to troubleshoot your system.



*Always unplug the power cord before adding, removing or changing any hardware components. Failure to do so may cause physical injuries to you and damages to motherboard components.*

1. Disconnect the power cable and check whether the PWR LED is off.
2. Unplug all cables, connectors and remove all add-on cards from the motherboard. Make sure that the jumpers are set to default settings.
3. Confirm that there are no short circuits between the motherboard and the chassis.
4. Install a CPU and fan on the motherboard, then connect the chassis speaker and power LED.

### **If there is no power...**

1. Confirm that there are no short circuits between the motherboard and the chassis.
2. Make sure that the jumpers are set to default settings.
3. Check the settings of the 115V/230V switch on the power supply.
4. Verify if the battery on the motherboard provides ~3VDC. Install a new battery if it does not.

### **If there is no video...**

1. Try replugging the monitor cables and power cord.
2. Check for memory errors.

### **If there are memory errors...**

1. Verify that the DIMM modules are properly seated in the slots.
2. Use recommended DDR4 ECC U-DIMMs.
3. If you have installed more than one DIMM modules, they should be identical with the same brand, speed, size and chip-type.
4. Try inserting different DIMM modules into different slots to identify faulty ones.
5. Check the settings of the 115V/230V switch on the power supply.

**Unable to save system setup configurations...**

1. Verify if the battery on the motherboard provides ~3VDC. Install a new battery if it does not.
2. Confirm whether your power supply provides adequate and stable power.

**Other problems...**

1. Try searching keywords related to your problem on ASRock Rack's FAQ page:  
<http://www.asrockrack.com/support>

## 5.2 Technical Support Procedures

If you have tried the troubleshooting procedures mentioned above and the problems are still unsolved, please contact ASRock Rack's technical support with the following information:

1. Your contact information
2. Model name, BIOS version and problem type.
3. System configuration.
4. Problem description.

You may contact ASRock Rack's technical support at:

<http://www.asrockrack.com/support/tsd.asp>

## 5.3 Returning Merchandise for Service

For warranty service, the receipt or a copy of your invoice marked with the date of purchase is required. By calling your vendor or going to our RMA website (<http://event.asrockrack.com/tsd.asp>) you may obtain a Returned Merchandise Authorization (RMA) number.

The RMA number should be displayed on the outside of the shipping carton which is mailed prepaid or hand-carried when you return the motherboard to the manufacturer. Shipping and handling charges will be applied for all orders that must be mailed when service is complete.

This warranty does not cover damages incurred in shipping or from failure due to alteration, misuse, abuse or improper maintenance of products.

Contact your distributor first for any product related problems during the warranty period.