



**H370M-HDV/M.2**

**Motherboard**

**Software/BIOS Setup Guide**

Version 1.0

Published September 2023

Copyright©2023 ASRock INC. All rights reserved.

Version 1.0

Published September 2023

Copyright©2023 ASRock INC. All rights reserved.

## Copyright Notice:

No part of this documentation may be reproduced, transcribed, transmitted, or translated in any language, in any form or by any means, except duplication of documentation by the purchaser for backup purpose, without written consent of ASRock Inc.

Products and corporate names appearing in this documentation may or may not be registered trademarks or copyrights of their respective companies, and are used only for identification or explanation and to the owners' benefit, without intent to infringe.

## Disclaimer:

Specifications and information contained in this documentation are furnished for informational use only and subject to change without notice, and should not be construed as a commitment by ASRock. ASRock assumes no responsibility for any errors or omissions that may appear in this documentation.

With respect to the contents of this documentation, ASRock does not provide warranty of any kind, either expressed or implied, including but not limited to the implied warranties or conditions of merchantability or fitness for a particular purpose.

In no event shall ASRock, its directors, officers, employees, or agents be liable for any indirect, special, incidental, or consequential damages (including damages for loss of profits, loss of business, loss of data, interruption of business and the like), even if ASRock has been advised of the possibility of such damages arising from any defect or error in the documentation or product.

## Contact Information:

If you need to contact ASRock or want to know more about ASRock, you're welcome to visit ASRock's website at <http://www.asrock.com>; or you may contact your dealer for further information. For technical questions, please submit a support request form at <https://event.asrock.com/tsd.asp>

### **ASRock Incorporation**

e-mail: [info@asrock.com.tw](mailto:info@asrock.com.tw)

### **ASRock EUROPE B.V.**

e-mail: [sales@asrock.nl](mailto:sales@asrock.nl)

### **ASRock America, Inc.**

e-mail: [sales@asrockamerica.com](mailto:sales@asrockamerica.com)

# Contents

<b>Chapter 1 Introduction</b>	<b>1</b>
<b>Chapter 2 Software and Utilities Operation</b>	<b>2</b>
2.1 Auto Driver Installer (ADI)	2
2.1.1 Installing Drivers for the First Time	2
2.1.2 Updating Drivers	6
2.2 ASRock Live Update & APP Shop	7
2.2.1 Installing ASRock Live Update & APP Shop	7
2.2.2 UI Overview	8
2.2.3 Apps	9
2.2.4 BIOS & Drivers	12
2.2.5 Setting	13
2.3 ASRock Motherboard Utility (A-Tuning)	14
2.3.1 Installing ASRock Motherboard Utility (A-Tuning)	14
2.3.2 Using ASRock Motherboard Utility (A-Tuning)	14
<b>Chapter 3 UEFI SETUP UTILITY</b>	<b>17</b>
3.1 Introduction	17
3.1.1 Entering BIOS Setup	17
3.1.2 EZ Mode	18
3.1.3 Advanced Mode	19
3.1.4 UEFI Menu Bar	19
3.1.5 Navigation Keys	20
3.2 Main Screen (Advanced Mode)	21

3.3	OC Tweaker Screen	22
3.4	Advanced Screen	31
3.4.1	CPU Configuration	32
3.4.2	Chipset Configuration	34
3.4.3	Storage Configuration	36
3.4.4	Super IO Configuration	37
3.4.5	ACPI Configuration	38
3.4.6	USB Configuration	39
3.4.7	Trusted Computing	41
3.5	Tools	43
3.6	Hardware Health Event Monitoring Screen	44
3.7	Security Screen	47
3.8	Boot Screen	52
3.9	Exit Screen	55

# Chapter 1 Introduction

This user guide is a complete setup guide for H370M-HDV/M.2 motherboard series. The screenshots in this manual are for reference only. Settings and options may vary due to the motherboard you purchased.

In this documentation, Chapter 1 gives an overview of the setup guide. Chapter 2 contains the operation guide of the software and utilities. Chapter 3 contains the configuration guide of the BIOS setup.

## Software Setup Guide

- Auto Driver Installer (ADI)
- ASRock Live Update & APP Shop
- ASRock Motherboard Utility (A-Tuning)

## BIOS Setup Guide

- UEFI Setup Utility



*Because the motherboard specifications and the software might be updated, the content of this documentation will be subject to change without notice. In case any modifications of this documentation occur, the updated version will be available on ASRock's website without further notice. If you require technical support related to this motherboard, please visit our website for specific information about the model you are using. ASRock website <http://www.asrock.com>.*

# Chapter 2 Software and Utilities Operation

## 2.1 Auto Driver Installer (ADI)

Optical drive or driver DVD is no longer needed for driver installation. ASRock motherboard already has its Ethernet driver prepacked in BIOS ROM. When you finish installing the operation system, simply use the Auto Driver Installer to download and install all necessary drivers automatically.

### 2.1.1 Installing Drivers for the First Time

Follow the instructions to install all necessary drivers via the Auto Driver Installer. Please note that the Internet access is required during the following procedures.

#### **Step 1**

After you install the Windows OS, connect your computer to the Internet.

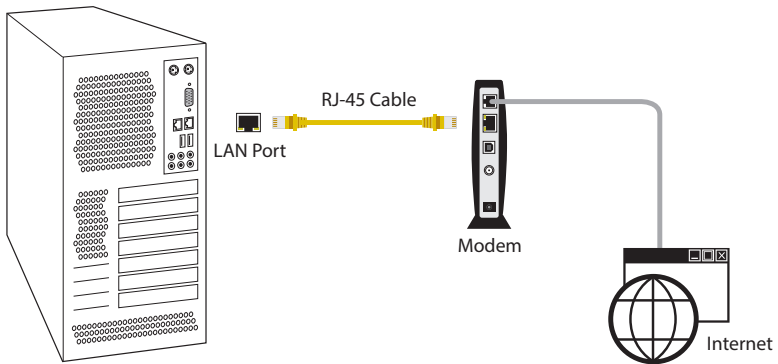

## Step 2

Boot into the system, and a notification will pop up in the lower right corner of your screen saying, "**Do you want to one-step-install the latest drivers simply from ASRock Auto Driver Installer?**".

Select "Yes" to install Auto Driver Installer.

Select "No" to skip the installation.



1. The Auto Driver Installer will automatically pop up for users to install drivers only when the "Auto Driver Installer" item under the "Tool" menu in the BIOS is set to [Enabled]. The item is enabled by default; therefore, for the first-time users, there is no need to change the setting in the BIOS.
2. An available Internet connection is a prerequisite for using the Auto Driver Installer. If you boot into the system without Internet, the Auto Driver Installer won't appear. Now connect your computer to the Internet, wait a few seconds, and then the Auto Driver Installer will pop up.
3. If you select "No" in Step 2 and skip the installation, the Auto Driver Installer will be removed. If you would like to run the application again, please enable the "Auto Driver Installer" item in the BIOS setting.

## Step 3

When it's completed, you will see the Auto Driver Installer icon on your desktop and then the Auto Driver Installer appears.



#### Step 4

The Auto Driver Installer panel lists all available drivers that your motherboard supports. Select one or more drivers to be installed.

Click "Select All" to select all items.

Click "Unselect All" to remove all of your selections.

Click "Update" to start downloading and installing drivers.

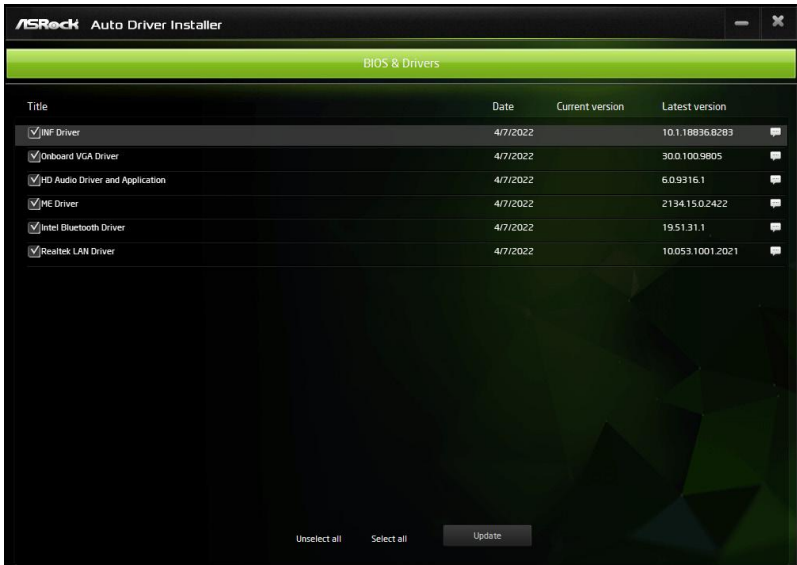

*If there are no drivers to be installed, click "Finish" to exit. If you would like to run the application again, please enable the "Auto Driver Installer" item in the BIOS setting.*

**Step 5**

A message pops up saying, "During installation, your system may reboot and continue installing remaining item(s)".

Click "Yes" to continue.

Click "No" to exit.

**Step 6**

Once all drivers are successfully installed, a message pops up saying, "Installation has been successfully completed! For further drivers and utilities, please visit ASRock's website."

Click "Ok" to complete the procedure.

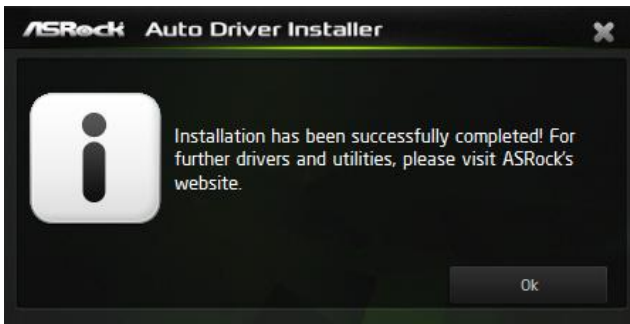

When driver installation is completed, the Auto Driver Installer tool will be uninstalled automatically from your computer.



*After driver installation, the Auto Driver Installer will be removed. If you would like to run the application again, please go to the "Tool" menu in the BIOS setting, and set the "Auto Driver Installer" item to [Enabled].*

## 2.1.2 Updating Drivers

Updating drivers ensures that your system work well without any issue. To update drivers, please go to ASRock' website (<https://www.asrock.com>) and select "Support" > "Latest Drivers Update".

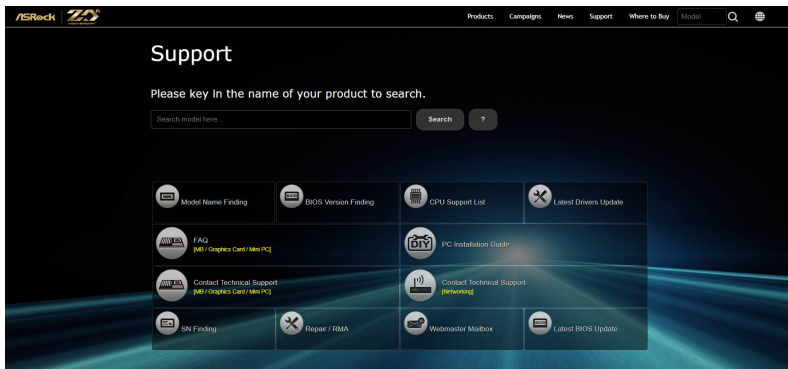

## 2.2 ASRock Live Update & APP Shop

The ASRock Live Update & APP Shop is an online store for purchasing and downloading software applications for your ASRock computer. You can quickly and easily install various apps and support utilities. With ASRock Live Update & APP Shop, you can optimize your system and keep your motherboard up to date simply with a few clicks.

### 2.2.1 Installing ASRock Live Update & APP Shop

Please download the ASRock Live Update & APP Shop utility from the ASRock's website: "https://www.asrock.com".

Go to the product page of your motherboard, select "Support" > "Download" to download the APP Shop.

Description	OS	Size	Date	Download
Realtek high definition audio driver ver.9231.1_LIAD_WHQL_Nahimic	Windows® 11 64bit	35.5MB	2021/10/12	<a href="#">Global</a> <a href="#">China</a>
AMD chipset driver ver.3.10.22.706	Windows® 11 64bit	50.33MB	2021/11/30	<a href="#">Global</a> <a href="#">China</a>
Killer Lan driver ver:3.0.1606	Windows® 11 64bit	38.8MB	2021/10/8	<a href="#">Global</a> <a href="#">China</a>
AMD RAIDXpert2 Utility ver.9.2.0.158	Windows® 11 64bit	95.4MB	2021/5/31	<a href="#">Global</a> <a href="#">China</a>
SATA Floppy Image_CC ver:9.3.0.296	Windows® 11 64bit	361KB	2022/2/8	<a href="#">Global</a> <a href="#">China</a>
SATA Floppy Image_DID ver:9.3.0.296	Windows® 11 64bit	361KB	2022/2/8	<a href="#">Global</a> <a href="#">China</a>
<b>NVMe_DID Supported AMD processors:</b> (Ryzen) - AMD Ryzen™ 5000 Series Desktop Processors with Radeon™ Graphics (Renoir) - AMD Ryzen™ 4000 Series Desktop Processors with Radeon™ Graphics (Cezanne) - AMD Ryzen™ 5000 Series Desktop Processors with Radeon™ Graphics	Windows® 11 64bit	361KB	2022/2/8	<a href="#">Global</a> <a href="#">China</a>
VGA driver ver.21.30.02.210727a_0827	Windows® 11 64bit	587MB	2021/10/8	<a href="#">Global</a> <a href="#">China</a>
ASRock Motherboard Utility ver.3.0.466	Windows® 11 64bit	59.40MB	2022/5/17	<a href="#">Global</a> <a href="#">China</a>
APP Shop ver:1.0.52	Windows® 11 64bit	3.91MB	2021/5/31	<a href="#">Global</a> <a href="#">China</a>
Nahimic3 Utility ver.210913_APO4	Windows® 11 64bit	85.3MB	2021/11/8	<a href="#">Global</a> <a href="#">China</a>
Norton Security ver.22.21.5	Windows® 11 64bit	232MB	2021/10/8	<a href="#">Global</a> <a href="#">China</a>
Restart to UEFI ver.1.0.9	Windows® 11 64bit	1.01MB	2021/10/8	<a href="#">Global</a> <a href="#">China</a>
[Beta] ASRock Motherboard Utility ver.3.0.441	Windows® 11 64bit	59.31MB	2021/12/14	<a href="#">Global</a> <a href="#">China</a>

After installation, double-click  on your desktop to access ASRock Live Update & APP Shop utility.

*\*You need to be connected to the Internet to download apps from the ASRock Live Update & APP Shop.*

## 2.2.2 UI Overview

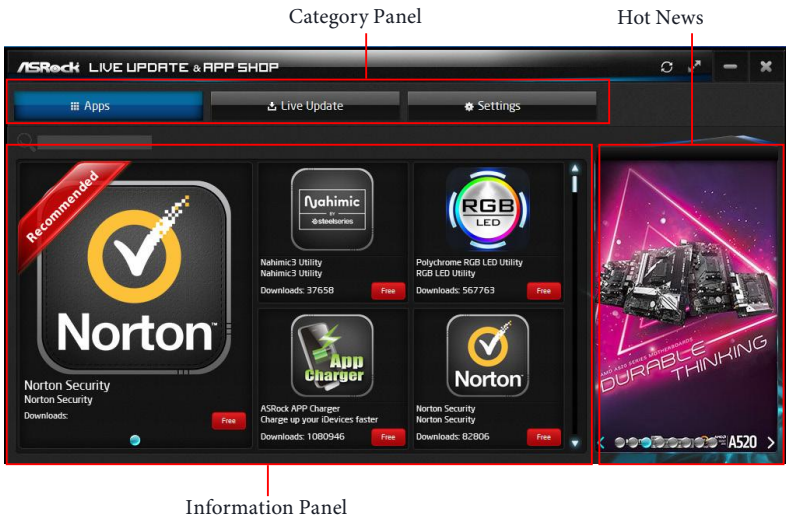

**Category Panel:** The category panel contains several category tabs or buttons that when selected the information panel below displays the relative information.

**Information Panel:** The information panel in the center displays data about the currently selected category and allows users to perform job-related tasks.

**Hot News:** The hot news section displays the various latest news. Click on the image to visit the website of the selected news and know more.

## 2.2.3 Apps

When the "Apps" tab is selected, you will see all the available apps on screen for you to download.

### Installing an App

#### Step 1

Find the app you want to install.



The most recommended app appears on the left side of the screen. The other various apps are shown on the right. Please scroll up and down to see more apps listed.

You can check the price of the app and whether you have already installed it or not.

**Free** - The red icon displays the price or "Free" if the app is free of charge.

**Installed** - The green "Installed" icon means the app is installed on your computer.

#### Step 2

Click on the app icon to see more details about the selected app.

### Step 3

If you want to install the app, click on the red icon  to start downloading.



### Step 4

When installation completes, you can find the green "Installed" icon appears on the upper right corner.



To uninstall it, simply click on the trash can icon .

\*The trash icon may not appear for certain apps.

## Upgrading an App

You can only upgrade the apps you have already installed. When there is an available new version for your app, you will find the mark of "New Version"  appears below the installed app icon.



### Step 1

Click on the app icon to see more details.

### Step 2

Click on the yellow icon  to start upgrading.

## 2.2.4 BIOS & Drivers

### Installing BIOS or Drivers

When the "BIOS & Drivers" tab is selected, you will see a list of recommended or critical updates for the BIOS or drivers. Please update them all soon.

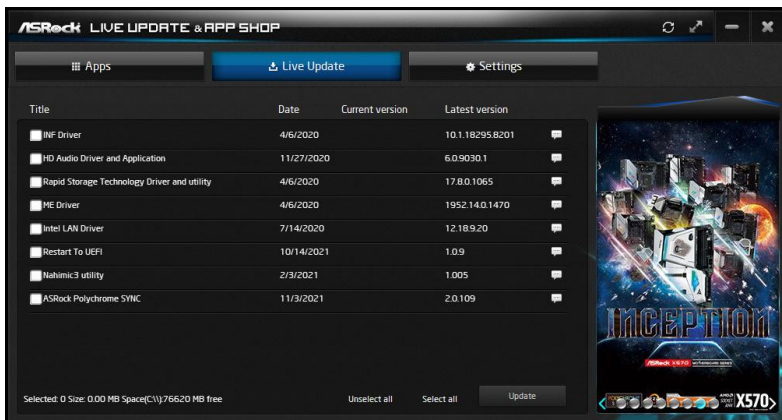

#### **Step 1**

Please check the item information before update. Click on  to see more details.

#### **Step 2**

Click to select one or more items you want to update.

#### **Step 3**

Click Update to start the update process.

## 2.2.5 Setting

In the "Setting" page, you can change the language, select the server location, and determine if you want to automatically run the ASRock Live Update & APP Shop on Windows startup.

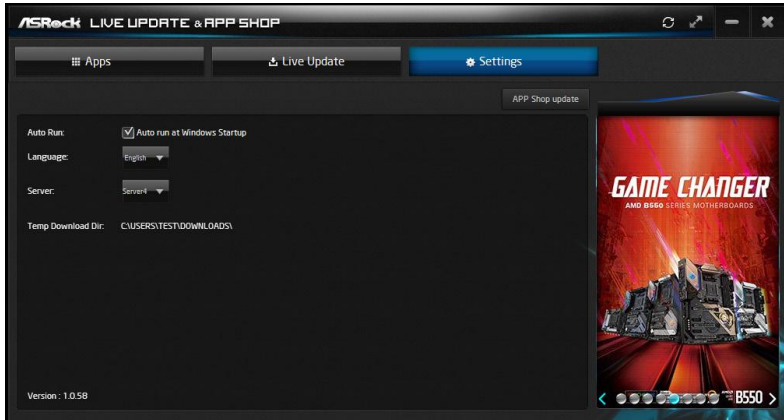

## 2.3 ASRock Motherboard Utility (A-Tuning)

ASRock Motherboard Utility (A-Tuning) is ASRock's multi purpose software suite with a new interface, more new features and improved utilities.

### 2.3.1 Installing ASRock Motherboard Utility (A-Tuning)

ASRock Motherboard Utility (A-Tuning) can be downloaded from ASRock Live Update & APP Shop.

You can also download the utility from the ASRock's website: "<https://www.asrock.com>". Go to the product page of your motherboard, select "Support" > "Download" to download "ASRock Motherboard Utility".

After the installation, you will find the icon "ASRock Motherboard Utility (A-Tuning)" on your desktop. Double-click the "ASRock Motherboard Utility (A-Tuning)" icon , ASRock Motherboard Utility (A-Tuning) main menu will pop up.

### 2.3.2 Using ASRock Motherboard Utility (A-Tuning)

There are five sections in ASRock Motherboard Utility (A-Tuning) main menu: Operation Mode, OC Tweaker, System Info, FAN-Tastic Tuning and Settings.

#### Operation Mode

Choose an operation mode for your computer.

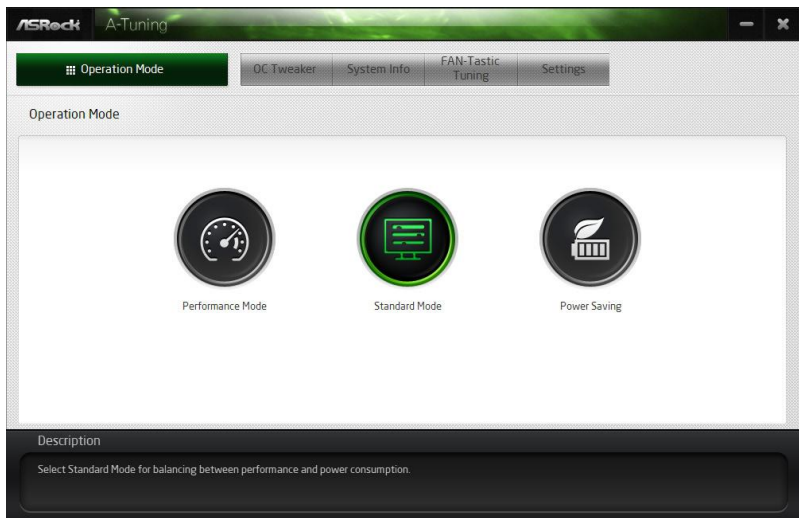

## OC Tweaker

Configurations for overclocking the system.

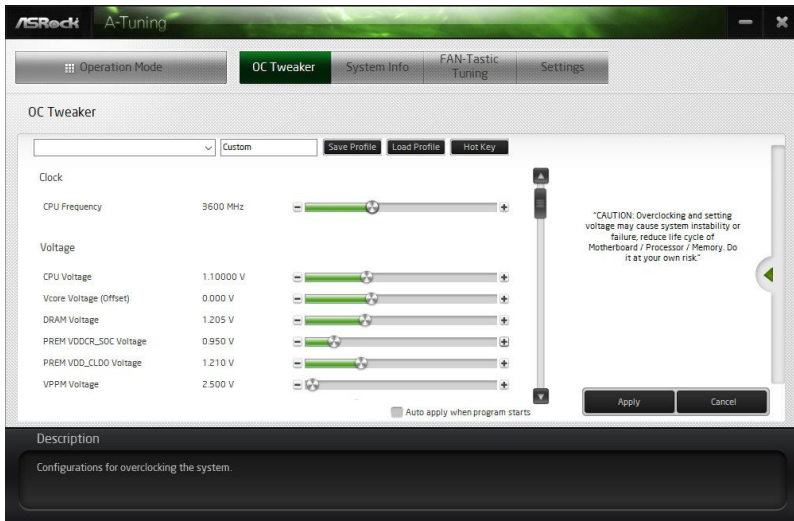

## System Info

View information about the system.

\*The System Browser tab may not appear for certain models.

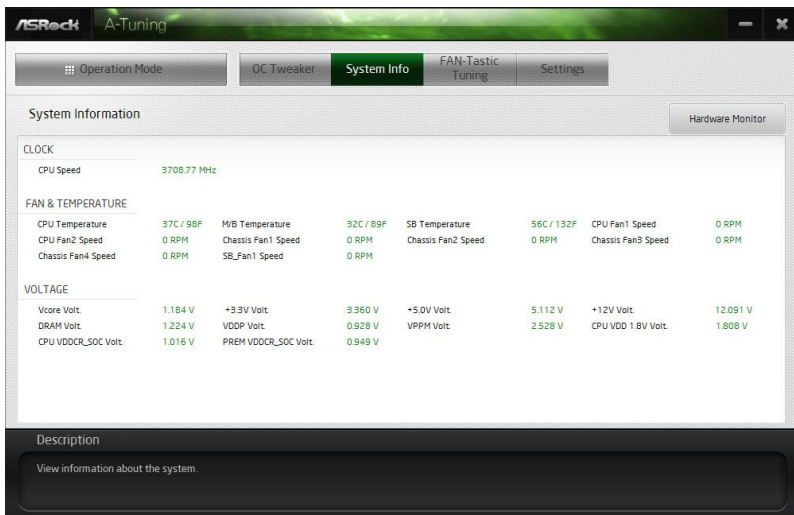

## FAN-Tastic Tuning

Configure up to five different fan speeds using the graph. The fans will automatically shift to the next speed level when the assigned temperature is met.

The screenshot shows the 'FAN-Tastic Tuning' window in ASRock A-Tuning. It features a graph with the following data points:

Temperature (C)	FAN Speed (%)
40	50
50	60
60	80
70	90
80	100

The table on the right shows the following settings:

Fan Power	Fan Speed
100%	N/A RPM
90%	N/A RPM
80%	N/A RPM
70%	N/A RPM
60%	N/A RPM
50%	N/A RPM
40%	N/A RPM
30%	N/A RPM
20%	N/A RPM
10%	N/A RPM

The 'Description' section states: "Configure different fan speeds for respective temperatures using the graph. The fans will automatically shift to the next speed level when the assigned temperature is met."

## Settings

Configure ASRock ASRock Motherboard Utility (A-Tuning). Click to select "Auto run at Windows Startup" if you want ASRock Motherboard Utility (A-Tuning) to be launched when you start up the Windows operating system.

The screenshot shows the 'Settings' window in ASRock A-Tuning. The 'Auto run at Windows Startup' checkbox is checked. The 'Description' section states: "Configure ASRock A-Tuning."

# Chapter 3 UEFI SETUP UTILITY

## 3.1 Introduction

ASRock UEFI (Unified Extensible Firmware Interface) is a BIOS utility which offers tweak-friendly options in an advanced viewing interface. The UEFI system works with a USB mouse and offers users a faster, sleeker experience.

This BIOS utility can perform the Power-On Self-Test (POST) during system startup, record hardware parameters of the system, load operating system, and so on. The battery on the motherboard supplies the power needed to the CMOS when the system power is turned off, and the values configured in the UEFI utility are kept in the CMOS.

Please note that inadequate BIOS settings may cause system instability, malfunction or boot failure. We strongly recommend that you do not alter the UEFI default configurations or change the settings only with the assistance of a trained service person.

If the system becomes unstable or fails to boot after you change the setting, try to clear the CMOS values and reset the board to default values. See your motherboard manual for instructions.

### 3.1.1 Entering BIOS Setup

You may run the UEFI SETUP UTILITY by pressing <F2> or <Del> right after you power on the computer; otherwise, the Power-On-Self-Test (POST) will continue with its test routines. If you wish to enter the UEFI SETUP UTILITY after POST, restart the system by pressing <Ctl> + <Alt> + <Delete>, or by pressing the reset button on the system chassis. You may also restart by turning the system off and then back on.

This setup guide explains how to use the UEFI SETUP UTILITY to configure all the supported system. The screenshots in this manual are for reference only. UEFI Settings and options may vary owing to different BIOS release versions or CPU installed. Please refer to the actual BIOS version of the motherboard you purchased for detailed screens, settings and options.

### 3.1.2 EZ Mode

The EZ Mode screen appears when you enter the BIOS setup program by default. EZ mode is a dashboard which contains multiple readings of the system's current status. You can check the most crucial information of your system, such as CPU speed, DRAM frequency, SATA information, fan speed, etc.

Press <F6> or click the "Advanced Mode" button at the upper right corner of the screen to switch to "Advanced Mode" for more options.

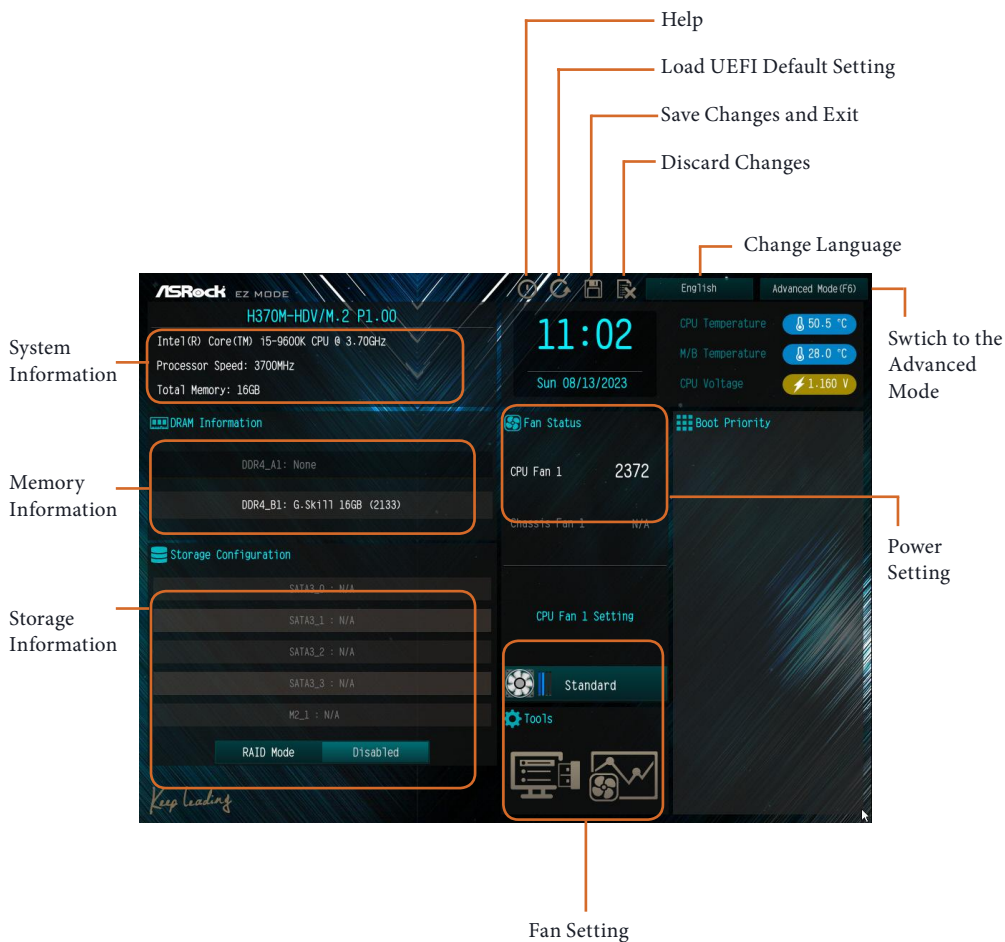

### 3.1.3 Advanced Mode

The Advanced Mode provides more options to configure the BIOS settings. Refer to the following sections for the detailed configurations.

To access the EZ Mode, press <F6> or click the "EZ Mode" button at the upper right corner of the screen.

### 3.1.4 UEFI Menu Bar

The top of the screen has a menu bar with the following selections:

<b>Main</b>	For setting system time/date information
<b>OC Tweaker</b>	For overclocking configurations
<b>Advanced</b>	For advanced system configurations
<b>Tool</b>	Useful tools
<b>H/W Monitor</b>	Displays current hardware status
<b>Security</b>	For security settings
<b>Boot</b>	For configuring boot settings and boot priority
<b>Exit</b>	Exit the current screen or the UEFI Setup Utility



*Because the UEFI software is constantly being updated, the following UEFI setup screens and descriptions for reference purpose only, and may vary from the latest BIOS and do not exactly match what you see on your screen.*



*Please realize that there is a certain risk involved with overclocking, including adjusting the setting in the BIOS, applying Untied Overclocking Technology, or using third-party overclocking tools. Overclocking may affect your system's stability, or even cause damage to the components and devices of your system. It should be done at your own risk and expense. We are not responsible for possible damage caused by overclocking.*

### 3.1.5 Navigation Keys

Use <←→> key or <→> key to choose among the selections on the menu bar, and use <↑> key or <↓> key to move the cursor up or down to select items, then press <Enter> to get into the sub screen. You can also use the mouse to click your required item.

Please check the following table for the descriptions of each navigation key.

Navigation Key(s)	Description
+ / -	To change option for the selected items
<Tab>	Switch to next function
<PGUP>	Go to the previous page
<PGDN>	Go to the next page
<HOME>	Go to the top of the screen
<END>	Go to the bottom of the screen
<F1>	To display the General Help Screen
<F7>	Discard changes and exit the SETUP UTILITY
<F9>	Load optimal default values for all the settings
<F10>	Save changes and exit the SETUP UTILITY
<F12>	Print screen
<ESC>	Jump to the Exit Screen or exit the current screen

## 3.2 Main Screen (Advanced Mode)

When you enter the UEFI SETUP UTILITY, the Main screen will appear and display the system overview.



### My Favorite

Display your collection of BIOS items. Press F5 to add/remove your favorite items.



*Because the UEFI software is constantly being updated, the following UEFI setup screens and descriptions are for reference purpose only, and they may not exactly match what you see on your screen. Options may also vary depending on the features of your motherboard.*

## 3.3 OC Tweaker Screen

In the OC Tweaker screen, you can set up overclocking features.



### CPU Configuration

#### Boot Performance Mode

Default is Max Non-Turbo performance mode. It will keep cpu Flex-ratio till OS handoff. Max Battery mode will set CPU ratio as x8 till OS handoff. This option is suggested for BCLK overclocking.

#### FCLK Frequency

Default is 800Mhz. If you want to overclock BCLK over 190 Mhz, 400Mhz is suggested value.

#### AVX Ratio Offset

AVX Ratio Offset specifies a negative offset from the CPU Ratio for AVX workloads. AVX is a more stressful workload. It is helpful to lower the AVX ratio to ensure maximum possible ratio for SSE workloads.

#### BCLK Aware Adaptive Voltage

Allows you to set BCLK Aware Adaptive Voltage as enabled or disabled. When it is enabled, pcode will be aware of the BCLK frequency when calculating the CPU V/F curves. This is ideal for BCLK OC to avoid high voltage overrides.

## Ring to Core Ratio Offset

Disable Ring to Core Ratio Offset so the ring and core can run at the same frequency.

## Intel SpeedStep Technology

Intel SpeedStep technology allows processors to switch between multiple frequencies and voltage points for better power saving and heat dissipation. CPU turbo ratio can be fixed when Intel SpeedStep Technology is set to Disabled and Intel Turbo Boost Technology is set to Enabled.

## Intel Turbo Boost Technology

Intel Turbo Boost Technology enables the processor to run above its base operating frequency when the operating system requests the highest performance state.

## Intel Speed Shift Technology

Enable/Disable Intel Speed Shift Technology support. Enabling will expose the CPPC v2 interface to allow for hardware controlled P-states.

## Long Duration Power Limit

Configure Package Power Limit 1 in watts. When the limit is exceeded, the CPU ratio will be lowered after a period of time. A lower limit can protect the CPU and save power, while a higher limit may improve performance.

## Long Duration Maintained

Configure the period of time until the CPU ratio is lowered when the Long Duration Power Limit is exceeded.

## Short Duration Power Limit

Configure Package Power Limit 2 in watts. When the limit is exceeded, the CPU ratio will be lowered immediately. A lower limit can protect the CPU and save power, while a higher limit may improve performance.

## CPU Core Current Limit

Configure the current limit of the CPU core. A lower limit can protect the CPU and save power, while a higher limit may improve performance.

## GT Current Limit

Configure the voltage regulator current limit. This value represents the Maximum instantaneous current allowed at any given time.

## GT Frequency

Configure the frequency of the integrated GPU.

## DRAM Configuration

### DRAM Tweaker

Fine tune the DRAM settings by leaving marks in checkboxes. Click OK to confirm and apply your new settings.

### DRAM Timing Configuration

#### DRAM Frequency Clock

Select Auto for optimized settings.

#### DRAM Frequency

If [Auto] is selected, the motherboard will detect the memory module(s) inserted and assign the appropriate frequency automatically.

#### DRAM Clock

Choose a frequency to override to clock delay for memory training. DRAM Clock controls memory training only if ASRock Timing Optimization is disabled.

## Primary Timing

### CAS# Latency (tCL)

The time between sending a column address to the memory and the beginning of the data in response.

### RAS# to CAS# Delay and Row Precharge (tRCDtRP)

RAS# to CAS# Delay : The number of clock cycles required between the opening of a row of memory and accessing columns within it.

Row Precharge: The number of clock cycles required between the issuing of the precharge command and opening the next row.

### RAS# Active Time (tRAS)

The number of clock cycles required between a bank active command and issuing the precharge command.

### Command Rate (CR)

The delay between when a memory chip is selected and when the first active command can be issued.

## Secondary Timing

### Write Recovery Time (tWR)

The amount of delay that must elapse after the completion of a valid write operation, before an active bank can be precharged.

### Refresh Cycle Time (tRFC)

The number of clocks from a Refresh command until the first Activate command to the same rank.

### RAS to RAS Delay (tRRD\_L)

The number of clocks between two rows activated in different banks of the same rank.

### RAS to RAS Delay (tRRD\_S)

The number of clocks between two rows activated in different banks of the same rank.

### Write to Read Delay (tWTR\_L)

The number of clocks between the last valid write operation and the next read command to the same internal bank.

### Write to Read Delay (tWTR\_S)

The number of clocks between the last valid write operation and the next read command to the same internal bank.

### Read to Precharge (tRTP)

The number of clocks that are inserted between a read command to a row precharge command to the same rank.

### Four Activate Window (tFAW)

The time window in which four activates are allowed the same rank.

### CAS Write Latency (tCWL)

Configure CAS Write Latency.

## Third Timing

### tREFI

Configure refresh cycles at an average periodic interval.

## tCKE

Configure the period of time the DDR4 initiates a minimum of one refresh command internally once it enters Self-Refresh mode.

## Turn Around Timing

### tRDRD\_sg

Configure between module read to read delay.

### tRDRD\_dg

Configure between module read to read delay.

### tRDRD\_dr

Configure between module read to read delay.

### tRDRD\_dd

Configure between module read to read delay.

### tRDWR\_sg

Configure between module read to write delay.

### tRDWR\_dg

Configure between module read to write delay.

### tRDWR\_dr

Configure between module read to write delay.

### tRDWR\_dd

Configure between module read to write delay.

### tWRRD\_sg

Configure between module write to read delay.

### tWRRD\_dg

Configure between module write to read delay.

### tWRRD\_dr

Configure between module write to read delay.

### tWRRD\_dd

Configure between module write to read delay.

**tWRWR\_sg**

Configure between module write to write delay.

**tWRWR\_dg**

Configure between module write to write delay.

**tWRWR\_dr**

Configure between module write to write delay.

**tWRWR\_dd**

Configure between module write to write delay.

**Round Trip Timing****RTL Init Value**

Configure round trip latency init value for round trip latency training.

**IOL Init Value**

Configure IO latency init value for IO latency training.

**RTL (CH A)**

Configure round trip latency for channel A.

**RTL (CH B)**

Configure round trip latency for channel B.

**IOL (CH A)**

Configure IO latency for channel A.

**IOL (CH B)**

Configure IO latency for channel B.

**IOL Offset (CH A)**

Configure IO latency offset for channel A.

**IOL Offset (CH B)**

Configure IO latency offset for channel B.

**RFR Delay (CH A)**

Configure RFR Delay for Channel A.

## RFR Delay (CH B)

Configure RFR Delay for Channel B.

## ODT Setting

### ODT WR (A1)

Configure the memory on die termination resistors' WR for channel A.

### ODT WR (B1)

Configure the memory on die termination resistors' WR for channel B.

### ODT NOM (A1)

Use this to change ODT (CH A) Auto/Manual settings. The default is [Auto].

### ODT NOM (B1)

Use this to change ODT (CH B) Auto/Manual settings. The default is [Auto].

### ODT PARK (A1)

Configure the memory on die termination resistors' PARK for channel A.

### ODT PARK (B1)

Configure the memory on die termination resistors' PARK for channel B.

## COMP Setting

### RCOMP0: DQ ODT (Read)

Default is 121.

### RCOMP1: DQ /CLK Ron (Drive Strength)

Default is 75.

### RCOMP2: CMD/CTL Ron (Drive Strength)

Default is 100.

## DQ ODT Driving

Adjust ODT Driving for better signal. Default is 60.

## DQ Driving

Adjust DQ Driving for better signal. Default is 26.

## Command Driving

Adjust Command Driving for better signal. Default is 20.

## Control Driving

Adjust Control Driving for better signal. Default is 20.

## Clock Driving

Adjust Clock Driving for better signal. Default is 26.

## DQ Slew Rate

Adjust DQ Slew Rate for better signal. Default is 59.

## Command Slew Rate

Adjust Command Slew Rate for better signal. Default is 53 for IN, 89 for 2N.

## Control Slew Rate

Adjust Control Slew Rate for better signal. Default is 53.

## Clock Slew Rate

Adjust Clock Slew Rate for better signal. Default is 53.

## MRS Setting

### MRS tCL

Configure the tCL for Memory MRS MR0.

### MRS tWRtRTP

Configure the tWRtRTP for Memory MRS MRC.

### MRS tCWL

Configure the tCWL for Memory MRS MR2.

### MRS tCCD\_L

Configure the tCL for Memory MRS MR6.

## Advanced Setting

### ASRock Timing Optimization

Configure the fast path through the MRC.

### Realtime Memory Timing

Configure the realtime memory timings.

[Enabled] The system will allow performing realtime memory timing changes after MRC\_DONE.

## Command Tristate

Configure the Command Tristate Support.

## Exit On Failure

Configure the Exit On Failure for MRC training steps.

## Reset On Training Fail

Reset system if the MRC training fails.

## MRC Fast Boot

Enable Memory Fast Boot to skip DRAM memory training for booting faster.

## Voltage Configuration

### DRAM Voltage

Use this to configure DRAM Voltage. The default value is [Auto].

### PCH +1.0 Voltage

Configure the chipset voltage (1.0V).

## Save User Default

Type a profile name and press enter to save your settings as user default.

## Load User Default

Load previously saved user defaults.

## Save User UEFI Setup Profile to Disk

Save current UEFI settings as an user default profile to disk.

## Load User UEFI Setup Profile to Disk

Load previously saved user defaults from the disk.

## 3.4 Advanced Screen

In this section, you may set the configurations for the following items: CPU Configuration, Chipset Configuration, Storage Configuration, Super IO Configuration, ACPI Configuration, USB Configuration and Trusted Computing.



*Setting wrong values in this section may cause the system to malfunction.*

### UEFI Configuration

#### UEFI Setup Style

Select the default mode when entering the UEFI setup utility.

#### Active Page on Entry

Select the default page when entering the UEFI setup utility.

#### Full HD UEFI

When [Auto] is selected, the resolution will be set to 1920 x 1080 if the monitor supports Full HD resolution. If the monitor does not support Full HD resolution, then the resolution will be set to 1024 x 768. When [Disable] is selected, the resolution will be set to 1024 x 768 directly.

[Disabled]

When [Disabled] is selected, the resolution will be set to 1024 x 768 directly.

## 3.4.1 CPU Configuration



### Active Processor Cores

Select the number of cores to enable in each processor package.

### CPU C States Support

Enable CPU C States Support for power saving. It is recommended to keep C3, C6 and C7 all enabled for better power saving.

### Enhanced Halt State (C1E)

Enable Enhanced Halt State (C1E) for lower power consumption.

### CPU C3 State Support

Enable C3 sleep state for lower power consumption.

### CPU C6 State Support

Enable C6 sleep state for lower power consumption.

### CPU C7 State Support

Enable C7 sleep state for lower power consumption.

### CPU C10 State Support

Enable C10 sleep state for lower power consumption.

## Package C State Support

Enable CPU, PCIe, Memory, Graphics C State Support for power saving.

## CFG Lock

This item allows you to disable or enable the CFG Lock.

## CPU Thermal Throttling

Enable CPU internal thermal control mechanisms to keep the CPU from overheating.

## Intel Virtualization Technology

Intel Virtualization Technology allows a platform to run multiple operating systems and applications in independent partitions, so that one computer system can function as multiple virtual systems.

## Hardware Prefetcher

Automatically prefetch data and code for the processor. Enable for better performance.

## Adjacent Cache Line Prefetch

Automatically prefetch the subsequent cache line while retrieving the currently requested cache line. Enable for better performance.

## Software Guard Extensions (SGX)

Use this item to enable or disable Software Controlled Software Guard Extensions (SGX).

## 3.4.2 Chipset Configuration



### Primary Graphics Adapter

Select a primary VGA.

### Above 4G Decoding

Enable or disable 64bit capable Devices to be decoded in Above 4G Address Space (only if the system supports 64 bit PCI decoding).

### VT-d

Intel® Virtualization Technology for Directed I/O helps your virtual machine monitor better utilize hardware by improving application compatibility and reliability, and providing additional levels of manageability, security, isolation, and I/O performance.

### PCIe1 Link Speed

Select the link speed for PCIe1.

### PCIe2 Link Speed

Select the link speed for PCIe2.

### PCI Express Native Control

Select Enable for enhanced PCI Express power saving in OS.

### PCIe ASPM Support

This option enables/disables the ASPM support for all CPU downstream devices.

### PCH PCIe ASPM Support

This option enables/disables the ASPM support for all PCH PCIe devices.

### DMI ASPM Support

This option enables/disables the control of ASPM on CPU side of the DMI Link.

### PCH DMI ASPM Support

This option enables/disables the ASPM support for all PCH DMI devices.

### Share Memory

Configure the size of memory that is allocated to the integrated graphics processor when the system boots up.

### IGPU Multi-Monitor

Select disable to disable the integrated graphics when an external graphics card is installed. Select enable to keep the integrated graphics enabled at all times.

### Onboard LAN

Allows you to enable or disable Onboard LAN.

### Onboard HD Audio

Enable/disable onboard HD audio. Set to Auto to enable onboard HD audio and automatically disable it when a sound card is installed.

### Front Panel

Enable/disable front panel HD audio.

### Onboard HDMI HD Audio

Enable audio for the onboard digital outputs.

### Deep Sleep

Configure deep sleep mode for power saving when the computer is shut down.

### Restore on AC/Power Loss

Select the power state after a power failure. If [Power Off] is selected, the power will remain off when the power recovers. If [Power On] is selected, the system will start to boot up when the power recovers.

### 3.4.3 Storage Configuration



#### SATA Controller(s)

Enable/disable the SATA controllers.

#### SATA Mode Selection

[AHCI] Supports new features that improve performance.

[Intel RST Premium (RAID)] Combine multiple disk drives into a logical unit.

#### SATA Aggressive Link Power Management

SATA Aggressive Link Power Management allows SATA devices to enter a low power state during periods of inactivity to save power. It is only supported by AHCI mode.

#### Hard Disk S.M.A.R.T.

S.M.A.R.T stands for Self-Monitoring, Analysis, and Reporting Technology. It is a monitoring system for computer hard disk drives to detect and report on various indicators of reliability.

## 3.4.4 Super IO Configuration



### PS2 Y-Cable

Enable the PS2 Y-Cable or set this option to Auto.

## 3.4.5 ACPI Configuration



### Suspend to RAM

Select disable for ACPI suspend type S1. It is recommended to select auto for ACPI S3 power saving.

### ACPI HPET Table

Enable the High Precision Event Timer for better performance.

### PS/2 Keyboard S4/S5 Wakeup Support

Allow the system to be waked up by a PS/2 Keyboard.

### PCIE Devices Power On

Allow the system to be waked up by a PCIE device and enable wake on LAN.

### RTC Alarm Power On

Allow the system to be waked up by the real time clock alarm. Set it to By OS to let it be handled by your operating system.

### USB Keyboard/Remote Power On

Allow the system to be waked up by an USB keyboard or remote controller.

### USB Mouse Power On

Allow the system to be waked up by an USB mouse.

## 3.4.6 USB Configuration



### Legacy USB Support

Enable or disable Legacy OS Support for USB 2.0 devices. If you encounter USB compatibility issues it is recommended to disable legacy USB support. Select UEFI Setup Only to support USB devices under the UEFI setup and Windows/Linux operating systems only.

### XHCI Hand-off

This is a workaround for OSEs without XHCI hand-off support. The XHCI ownership change should be claimed by XHCI driver.

### USB Single Port Control

#### USB Port 1

Enable or disable this USB Physical Connector (physical port). Once disabled, any USB devices plugged into the connector will not be detected by BIOS or OS.

#### USB Port 2

Enable or disable this USB Physical Connector (physical port). Once disabled, any USB devices plugged into the connector will not be detected by BIOS or OS.

#### USB Port 3

Enable or disable this USB Physical Connector (physical port). Once disabled, any USB devices plugged into the connector will not be detected by BIOS or OS.

## USB Port 4

Enable or disable this USB Physical Connector (physical port). Once disabled, any USB devices plugged into the connector will not be detected by BIOS or OS.

## USB Port 5

Enable or disable this USB Physical Connector (physical port). Once disabled, any USB devices plugged into the connector will not be detected by BIOS or OS.

## USB Port 6

Enable or disable this USB Physical Connector (physical port). Once disabled, any USB devices plugged into the connector will not be detected by BIOS or OS.

## USB3 Port 1

Enable or disable this USB Physical Connector (physical port). Once disabled, any USB devices plugged into the connector will not be detected by BIOS or OS.

## USB3 Port 2

Enable or disable this USB Physical Connector (physical port). Once disabled, any USB devices plugged into the connector will not be detected by BIOS or OS.

## USB3 Port 3

Enable or disable this USB Physical Connector (physical port). Once disabled, any USB devices plugged into the connector will not be detected by BIOS or OS.

## USB3 Port 4

Enable or disable this USB Physical Connector (physical port). Once disabled, any USB devices plugged into the connector will not be detected by BIOS or OS.

## 3.4.7 Trusted Computing



*NOTE: Options vary depending on the version of your connected TPM module.*

### Security Device Support

Allows you to enable or disable BIOS support for security device. O.S. will not show Security Device. TCG EFI protocol and INT1A interface will not be available.

Configuration options: [Enabled] [Disabled]

### Active PCR banks

This item displays active PCR Banks.

### Available PCR banks

This item displays available PCR Banks.

### SHA-1 PCR Bank

Allows you to enable or disable SHA-1 PCR Bank.

Configuration options: [Enabled] [Disabled]

### SHA256 PCR Bank

Allows you to enable or disable SHA256 PCR Bank.

Configuration options: [Enabled] [Disabled]

## Pending Operation

Allows you to schedule an Operation for the Security Device.

NOTE: Your computer will reboot during restart in order to change State of the Device.

Configuration options: [None] [TPM Clear]

## Platform Hierarchy

Allows you to enable or disable Platform Hierarchy.

Configuration options: [Enabled] [Disabled]

## Storage Hierarchy

Allows you to enable or disable Storage Hierarchy.

Configuration options: [Enabled] [Disabled]

## Endorsement Hierarchy

Allows you to enable or disable Endorsement Hierarchy.

Configuration options: [Enabled] [Disabled]

## TPM 2.0 UEFI Spec Version

Allows you to select the TCG2 Spec Version Support.

[TCG\_1\_2]: The Compatible mode for Win8/Win10.

[TCG\_2]: Support new TCG2 protocol and event format for Win10 or later.

## Physical Presence Spec Version

Select this item to tell OS to support PPI spec version 1.2 or 1.3. Please note that some HCK tests might not support version 1.3.

Configuration options: [1.2] [1.3]

## TPM 2.0 InterfaceType

Allows you to view the Communication Interface to TPM 2.0 Device: CRB or ITS.

## Device Select

Allows you to select the TPM device to be supported.

[TPM 1.2] restricts support to TPM 1.2 devices.

[TPM 2.0] restricts support to TPM 2.0 devices.

[Auto] supports both TPM 1.2 and TPM 2.0 devices with the default set to TPM 2.0 devices. If TPM 2.0 devices are not found, TPM 1.2 devices will be enumerated.

## 3.5 Tools

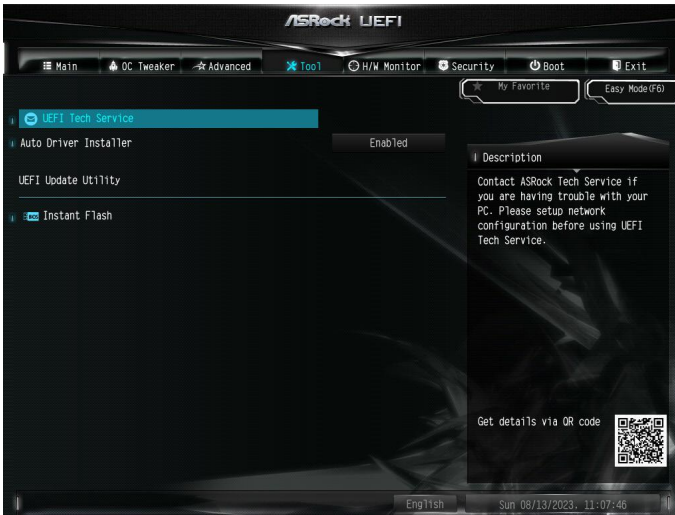

### UEFI Tech Service

Contact ASRock Tech Service if you are having trouble with your PC. Please setup network configuration before using UEFI Tech Service.

### Auto Driver Installer

Allows you to download and install all necessary drivers automatically.

[Enabled]

Select this item to enable the Auto Driver Installer tool. When it is enabled, after entering to Windows with available Internet access, the Auto Driver Installer tool will appear automatically.

[Disabled]

Select this item to disable the Auto Driver Installer tool.

### Instant Flash

Allows you to save UEFI files in your USB storage device and run Instant Flash to update your UEFI. Please note that your USB storage device must be FAT32/16/12 file system.

### 3.6 Hardware Health Event Monitoring Screen

This section allows you to monitor the status of the hardware on your system, including the parameters of the CPU temperature, motherboard temperature, fan speed and voltage.



*NOTE: Options vary depending on the features of your motherboard.*

#### Fan Tuning

When selected, the BIOS will proceed to detect the lowest fan speeds for fans connected to the motherboard. This process will take a few minutes to complete.

## Fan-Tastic Tuning

Allows you to select a fan mode for CPU Fan, or choose Customize to set 5 CPU temperatures and assign a respective fan speed for each temperature.

Select a fan mode or customize the profile

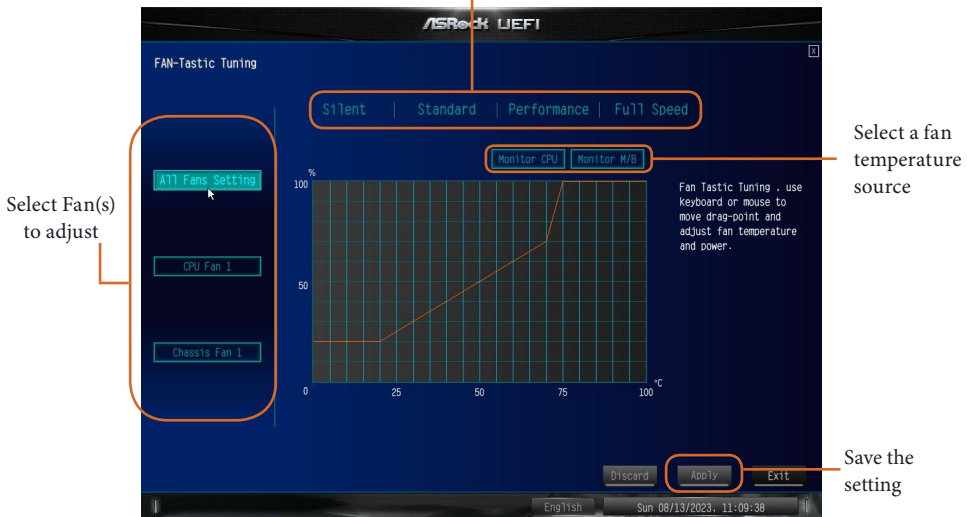

## CPU Fan 1 Setting

Allows you to select a fan mode for CPU Fan 1, or choose [Customize] to set 5 CPU temperatures and assign a respective fan speed for each temperature.

Configuration options:

[Customize] [Silent Mode] [Standard Mode] [Performance Mode] [Full Speed]

## CPU Fan 1 Step Up

Allows you to set the value of CPU Fan 1 Step Up. Configuration options: [Level 0] - [Level 9]

## CPU Fan 1 Step Down

Allows you to set the value of CPU Fan 1 Step Down.

Configuration options: [Level 0] - [Level 9]

## CHA\_FAN1/ WP Switch

Allows you to select Chassis Fan 1 or Water Pump mode.

Configuration options: [CHA\_FAN1] [W\_PUMP]

## Chassis Fan 1 Control Mode

Allows you to select PWM mode or DC mode for Chassis Fan 1.

[Auto] Select this mode to detect the type of installed fan and automatically switch the control modes.

[DC Mode] Select this mode for 3-pin fan.

[PWM Mode] Select this mode for 4-pin fan.

## Chassis Fan 1 Setting

Allows you to select a fan mode for Chassis Fan 1, or choose [Customize] to set 5 CPU temperatures and assign a respective fan speed for each temperature.

Configuration options:

[Customize] [Silent Mode] [Standard Mode] [Performance Mode] [Full Speed]

## Chassis Fan 1 Temp Source

Allows you to select a fan temperature source for Chassis Fan 1.

[Monitor M/B] Select this item to set motherboard as the fan temperature source.

[Monitor CPU] Select this item to set CPU as the fan temperature source.

## Chassis Fan 1 Step Up

Allows you to set the value of Chassis Fan 1 Step Up.

Configuration options: [Level 0] - [Level 9]

## Chassis Fan 1 Step Down

Allows you to set the value of Chassis Fan 1 Step Down.

Configuration options: [Level 0] - [Level 9]

## Over Temperature Protection

When Over Temperature Protection is enabled, the system automatically shuts down when the motherboard is overheated.

## Case Open Feature

Enable or disable Case Open Feature to detect whether the chassis cover has been removed.

## 3.7 Security Screen

In this section you may set or change the supervisor/user password for the system. You may also clear the user password.



### Supervisor Password

Set or change the password for the administrator account. Only the administrator has authority to change the settings in the UEFI Setup Utility. Leave it blank and press enter to remove the password.

### User Password

Set or change the password for the user account. Users are unable to change the settings in the UEFI Setup Utility. Leave it blank and press enter to remove the password.

### Secure Boot

Press [Enter] to configure the Secure Boot Settings. The feature protects the system from unauthorized access and malwares during POST.

### Secure Boot Mode

[Standard] Select this item and the system will automatically load the Secure Boot keys from the BIOS database.

[Custom] Select this item and Secure Boot Policy variables can be configured by a physically present user without full authentication.

## Install Default Secure Boot Keys

Please install default secure boot keys if it's the first time you use secure boot.

## Clear Secure Boot Keys

This item appears only when you load the default Secure Boot keys. Use this item to clear all default Secure Boot keys.

## Key Management

This item enables expert users to modify Secure Boot Policy variables without full authentication. This appears only when you set Secure Boot Mode to [Custom].

## Factory Key Provision

Allows you to install factory default Secure Boot keys after the platform reset and while the System is in Setup mode.

## Install Default Secure Boot Keys

Please install default secure boot keys if it's the first time you use secure boot.

## Clear Secure Boot Keys

This item appears only when you load the default Secure Boot keys. Use this item to clear all default Secure Boot keys.

## Export Secure Boot variables

Allows you to copy NVRAM content of Secure Boot variables to files in a root folder on a file\_system device.

## Enroll Efi Image

Allows Efi image to run in Secure Boot Mode. Enroll SHA256 Hash certificate of a PE image into Authorized Signature Database (db).

## Device Guard Ready

### Remove 'UEFI CA' from DB

Device Guard ready system must not list 'Microsoft UEFI CA' Certificate in Authorized Signature database (db).

## Restore DB Defaults

Use this item to restore DB variable to factory defaults.

## Platform Key(PK)

Enroll Factory Defaults or load certificates from a file:

1. Public Key Certificate:

- a) EFI\_SIGNATURE\_LIST
- b) EFI\_CERT\_X509 (DER)
- c) EFI\_CERT\_RSA2048 (bin)
- d) EFI\_CERT\_SHAXXX

2. Authenticated UEFI Variable

3. EFI PE/COFF Image(SHA256)

Key Source: Factory, External, Mixed

## Key Exchange Keys

Enroll Factory Defaults or load certificates from a file:

1. Public Key Certificate:

- a) EFI\_SIGNATURE\_LIST
- b) EFI\_CERT\_X509 (DER)
- c) EFI\_CERT\_RSA2048 (bin)
- d) EFI\_CERT\_SHAXXX

2. Authenticated UEFI Variable

3. EFI PE/COFF Image(SHA256)

Key Source: Factory, External, Mixed

## Authorized Signatures

Enroll Factory Defaults or load certificates from a file:

1. Public Key Certificate:

- a) EFI\_SIGNATURE\_LIST
- b) EFI\_CERT\_X509 (DER)
- c) EFI\_CERT\_RSA2048 (bin)
- d) EFI\_CERT\_SHAXXX

2. Authenticated UEFI Variable

3. EFI PE/COFF Image(SHA256)

Key Source: Factory, External, Mixed

## Forbidden Signatures

Enroll Factory Defaults or load certificates from a file:

1. Public Key Certificate:
  - a) EFI\_SIGNATURE\_LIST
  - b) EFI\_CERT\_X509 (DER)
  - c) EFI\_CERT\_RSA2048 (bin)
  - d) EFI\_CERT\_SHAXXX
2. Authenticated UEFI Variable
3. EFI PE/COFF Image(SHA256)

Key Source: Factory, External, Mixed

## Authorized TimeStamps

Enroll Factory Defaults or load certificates from a file:

1. Public Key Certificate:
  - a) EFI\_SIGNATURE\_LIST
  - b) EFI\_CERT\_X509 (DER)
  - c) EFI\_CERT\_RSA2048 (bin)
  - d) EFI\_CERT\_SHAXXX
2. Authenticated UEFI Variable
3. EFI PE/COFF Image(SHA256)

Key Source: Factory, External, Mixed

## OsRecovery Signatures

Enroll Factory Defaults or load certificates from a file:

1. Public Key Certificate:
  - a) EFI\_SIGNATURE\_LIST
  - b) EFI\_CERT\_X509 (DER)
  - c) EFI\_CERT\_RSA2048 (bin)
  - d) EFI\_CERT\_SHAXXX
2. Authenticated UEFI Variable

### 3. EFI PE/COFF Image(SHA256)

Key Source: Factory, External, Mixed

#### **Intel(R) Platform Trust Technology**

Allows you to enable or disable Intel PTT function.

[Enabled] Enables Intel PTT in ME.

[Disabled] Disables Intel PTT in ME. Use a discrete TPM Module.

Configuration options: [Enabled] [Disabled]

## 3.8 Boot Screen

This section displays the available devices on your system for you to configure the boot settings and the boot priority.



### Fast Boot

Fast Boot speeds up your computer's boot time; however, you won't be able to boot from an USB storage device. Ultra Fast mode is supported by UEFI aware OS or later versions, and a VBIOS that supports UEFI GOP is required if you are using an external graphics card. Please note that Ultra Fast mode boots so fast that the only way to enter this UEFI Setup Utility is to clear CMOS or run the Restart to UEFI utility in Windows.

Configuration options: [Disabled] [Ultra Fast]

### Boot From Onboard LAN

Allows the system to be waked up by the onboard LAN.

Configuration options: [Enabled] [Disabled]

### Setup Prompt Timeout

Allows you to configure the number of seconds to wait for the UEFI setup utility.

Configuration options: [1] - [65535]

### Bootup Num-Lock

Allows you to select whether Num Lock should be turned on or off when the system boots up.

Configuration options: [On] [Off]

### Boot Beep

Allows you to select whether the Boot Beep should be turned on or off when the system boots up. Please note that a buzzer is needed.

Configuration options: [Enabled] [Disabled]

### Full Screen Logo

[Enabled] Select this item to display the boot logo.

[Disabled] Select this item to show normal POST messages.

### AddOn ROM Display

Allows you to set display mode for Option ROM.

[Enabled]

Select this item to enable AddOn ROM Display to see the AddOn ROM messages or configure the AddOn ROM if you've enabled Full Screen Logo.

[Disabled]

Select this item to disable AddOn ROM Display for faster boot speed.

### Boot Failure Guard Message

If the computer fails to boot for a number of times the system automatically restores the default settings.

Configuration options: [Enabled] [Disabled]

## CSM (Compatibility Support Module)



### CSM

Allows you to enable and launch the Compatibility Support Module. Please do not disable unless you're running a WHCK test.

### Launch PXE OpROM Policy

[UEFI only] Select this item to run those that support UEFI option ROM only.

[Do not launch] Select this item to not execute both legacy and UEFI option ROM.

[Legacy only] Select this item to run those that support Legacy option ROM only.

### Launch Storage OpROM Policy

[UEFI only] Select this item to run those that support UEFI option ROM only.

[Do not launch] Select this item to not execute both legacy and UEFI option ROM.

[Legacy only] Select this item to run those that support Legacy option ROM only.

### Other PCI Device ROM Priority

Allows you to select whether to enable the UEFI or Legacy option ROM for the PCI device controller other than the network, mass storage device, and video graphics controllers.

Configuration options: [Do not launch] [UEFI only] [Legacy only]

### 3.9 Exit Screen

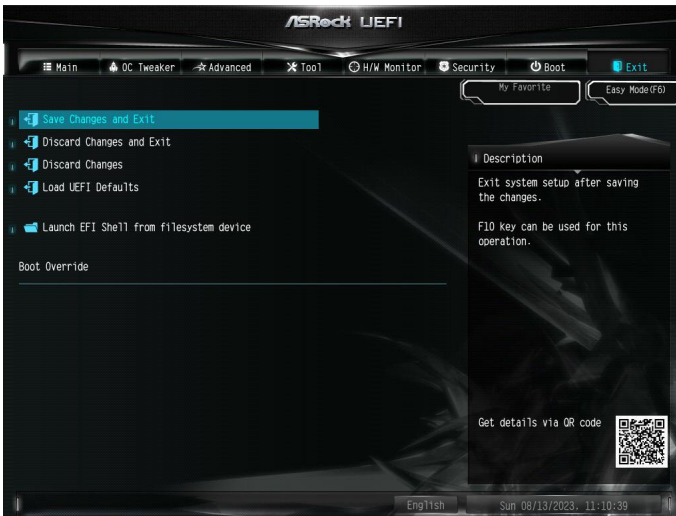

#### Save Changes and Exit

When you select this option the following message, “Save configuration changes and exit setup?” will pop out. Press <F10> key or select [Yes] to save the changes and exit the UEFI SETUP UTILITY.

#### Discard Changes and Exit

When you select this option the following message, “Discard changes and exit setup?” will pop out. Press <ESC> key or select [Yes] to exit the UEFI SETUP UTILITY without saving any changes.

#### Discard Changes

When you select this option the following message, “Discard changes?” will pop out. Press <F7> key or select [Yes] to discard all changes.

#### Load UEFI Defaults

Allows you to load UEFI default values for all options. The F9 key can be used for this operation.

#### Launch EFI Shell from filesystem device

Allows you to copy shellx64.efi to the root directory to launch EFI Shell.