

Version 1.0

Published April 2020

Copyright©2020 ASRock INC. All rights reserved.

### Copyright Notice:

No part of this documentation may be reproduced, transcribed, transmitted, or translated in any language, in any form or by any means, except duplication of documentation by the purchaser for backup purpose, without written consent of ASRock Inc.

Products and corporate names appearing in this documentation may or may not be registered trademarks or copyrights of their respective companies, and are used only for identification or explanation and to the owners' benefit, without intent to infringe.

### Disclaimer:

Specifications and information contained in this documentation are furnished for informational use only and subject to change without notice, and should not be construed as a commitment by ASRock. ASRock assumes no responsibility for any errors or omissions that may appear in this documentation.

With respect to the contents of this documentation, ASRock does not provide warranty of any kind, either expressed or implied, including but not limited to the implied warranties or conditions of merchantability or fitness for a particular purpose.

In no event shall ASRock, its directors, officers, employees, or agents be liable for any indirect, special, incidental, or consequential damages (including damages for loss of profits, loss of business, loss of data, interruption of business and the like), even if ASRock has been advised of the possibility of such damages arising from any defect or error in the documentation or product.



This device complies with Part 15 of the FCC Rules. Operation is subject to the following two conditions:

- (1) this device may not cause harmful interference, and
- (2) this device must accept any interference received, including interference that may cause undesired operation.

### CALIFORNIA, USA ONLY

The Lithium battery adopted on this motherboard contains Perchlorate, a toxic substance controlled in Perchlorate Best Management Practices (BMP) regulations passed by the California Legislature. When you discard the Lithium battery in California, USA, please follow the related regulations in advance.

“Perchlorate Material-special handling may apply, see [www.dtsc.ca.gov/hazardouswaste/perchlorate](http://www.dtsc.ca.gov/hazardouswaste/perchlorate)”

**ASRock Website: <http://www.asrock.com>**

---

## AUSTRALIA ONLY

Our goods come with guarantees that cannot be excluded under the Australian Consumer Law. You are entitled to a replacement or refund for a major failure and compensation for any other reasonably foreseeable loss or damage caused by our goods. You are also entitled to have the goods repaired or replaced if the goods fail to be of acceptable quality and the failure does not amount to a major failure. If you require assistance please call ASRock Tel : +886-2-28965588 ext.123 (Standard International call charges apply)

The terms HDMI® and HDMI High-Definition Multimedia Interface, and the HDMI logo are trademarks or registered trademarks of HDMI Licensing LLC in the United States and other countries.



# Motherboard Layout

## H410M-HDVP:

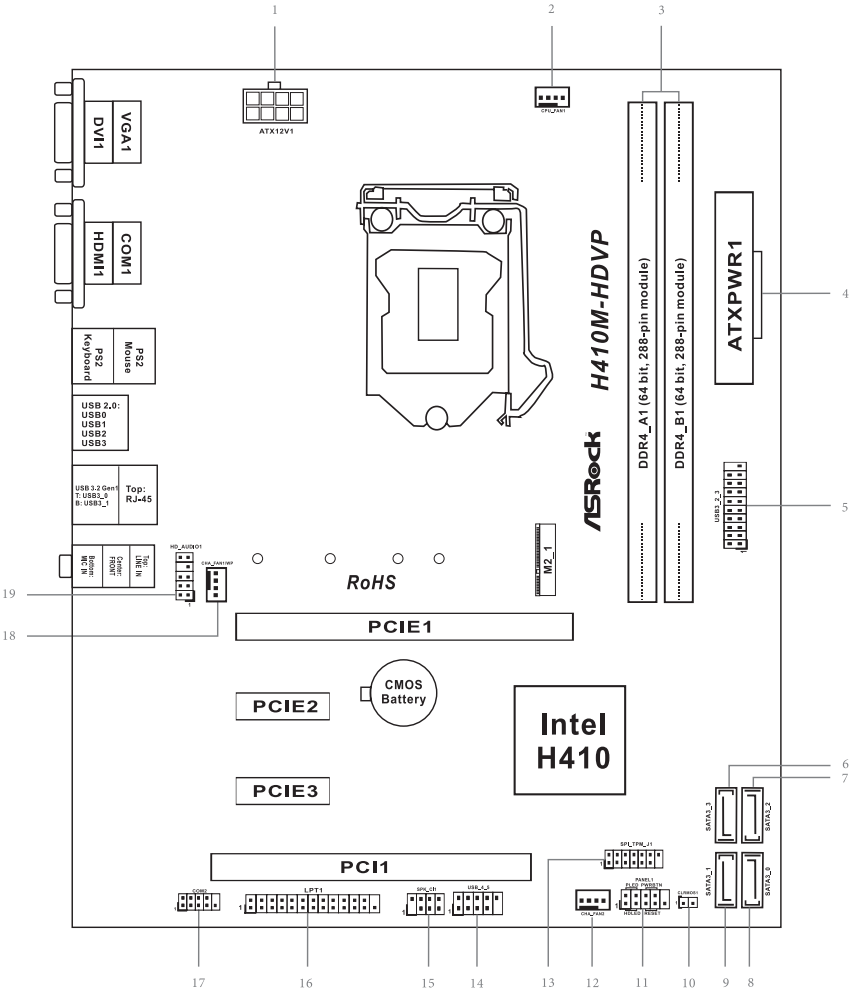

English

| No. | Description                                    |
|-----|--|
| 1   | ATX 12V Power Connector (ATX12V1)              |
| 2   | CPU Fan Connector (CPU_FAN1)                   |
| 3   | 2 x 288-pin DDR4 DIMM Slots (DDR4_A1, DDR4_B1) |
| 4   | ATX Power Connector (ATXPWR1)                  |
| 5   | USB 3.2 Gen1 Header (USB3_2_3)                 |
| 6   | SATA3 Connector (SATA3_3)                      |
| 7   | SATA3 Connector (SATA3_2)                      |
| 8   | SATA3 Connector (SATA3_0)                      |
| 9   | SATA3 Connector (SATA3_1)                      |
| 10  | Clear CMOS Jumper (CLRMOS1)                    |
| 11  | System Panel Header (PANEL1)                   |
| 12  | Chassis Fan Connector (CHA_FAN2)               |
| 13  | SPI TPM Header (SPI_TPM_J1)                    |
| 14  | USB 2.0 Header (USB_4_5)                       |
| 15  | Chassis Intrusion and Speaker Header (SPK_C11) |
| 16  | Print Port Header (LPT1)                       |
| 17  | COM Port Header (COM2)                         |
| 18  | Chassis/Water Pump Fan Connector (CHA_FAN1/WP) |
| 19  | Front Panel Audio Header (HD_AUDIO1)           |

H410M-HDVP2:

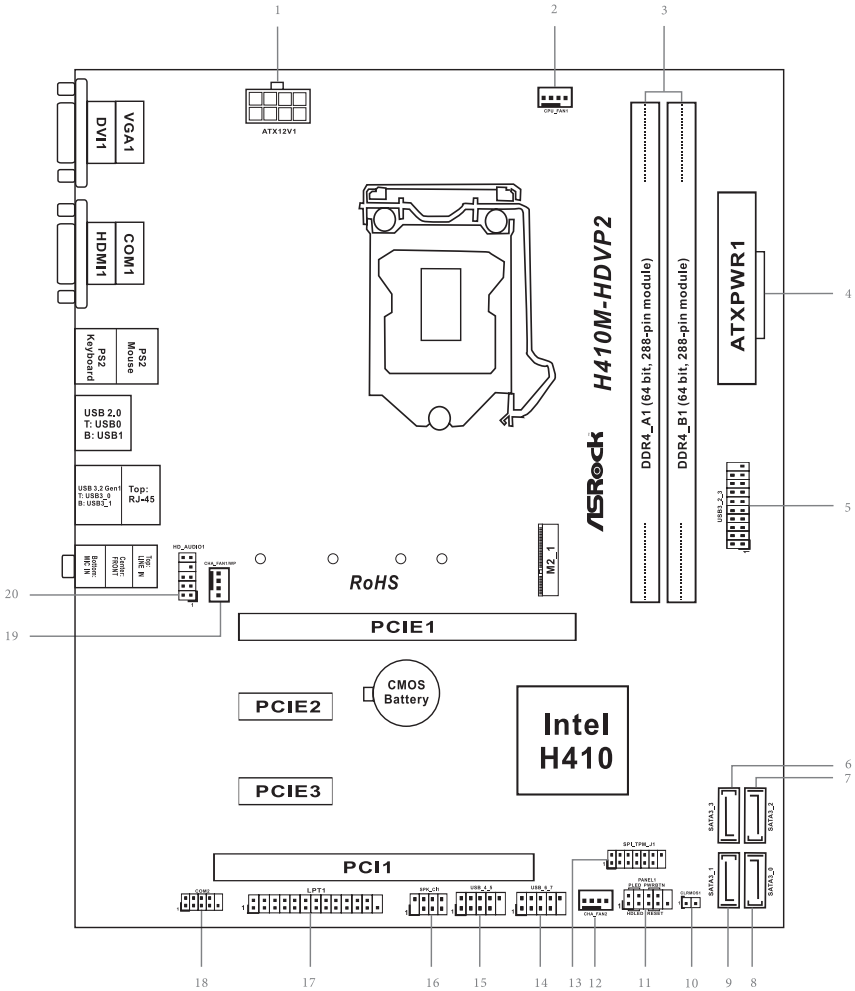

| No. | Description                                    |
|-----|--|
| 1   | ATX 12V Power Connector (ATX12V1)              |
| 2   | CPU Fan Connector (CPU_FAN1)                   |
| 3   | 2 x 288-pin DDR4 DIMM Slots (DDR4_A1, DDR4_B1) |
| 4   | ATX Power Connector (ATXPWR1)                  |
| 5   | USB 3.2 Gen1 Header (USB3_2_3)                 |
| 6   | SATA3 Connector (SATA3_3)                      |
| 7   | SATA3 Connector (SATA3_2)                      |
| 8   | SATA3 Connector (SATA3_0)                      |
| 9   | SATA3 Connector (SATA3_1)                      |
| 10  | Clear CMOS Jumper (CLRMOS1)                    |
| 11  | System Panel Header (PANEL1)                   |
| 12  | Chassis Fan Connector (CHA_FAN2)               |
| 13  | SPI TPM Header (SPI_TPM_J1)                    |
| 14  | USB 2.0 Header (USB_6_7)                       |
| 15  | USB 2.0 Header (USB_4_5)                       |
| 16  | Chassis Intrusion and Speaker Header (SPK_C11) |
| 17  | Print Port Header (LPT1)                       |
| 18  | COM Port Header (COM2)                         |
| 19  | Chassis/Water Pump Fan Connector (CHA_FAN1/WP) |
| 20  | Front Panel Audio Header (HD_AUDIO1)           |

## I/O Panel

### H410M-HDVP:

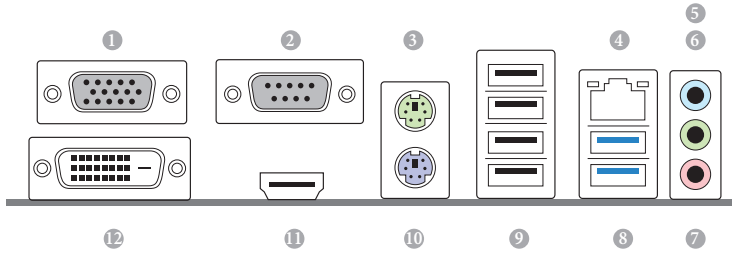

| No. | Description            | No. | Description                  |
|-----|------------------------|-----|------------------------------|
| 1   | D-Sub Port             | 7   | Microphone (Pink)**          |
| 2   | COM Port               | 8   | USB 3.2 Gen1 Ports (USB3_01) |
| 3   | PS/2 Mouse Port        | 9   | USB 2.0 Ports (USB0123)      |
| 4   | LAN RJ-45 Port*        | 10  | PS/2 Keyboard Port           |
| 5   | Line In (Light Blue)** | 11  | HDMI Port                    |
| 6   | Front Speaker (Lime)** | 12  | DVI-D Port                   |

### H410M-HDVP2:

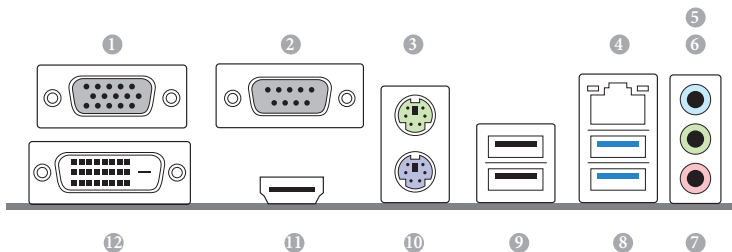

| No. | Description            | No. | Description                  |
|-----|------------------------|-----|------------------------------|
| 1   | D-Sub Port             | 7   | Microphone (Pink)**          |
| 2   | COM Port               | 8   | USB 3.2 Gen1 Ports (USB3_01) |
| 3   | PS/2 Mouse Port        | 9   | USB 2.0 Ports (USB01)        |
| 4   | LAN RJ-45 Port*        | 10  | PS/2 Keyboard Port           |
| 5   | Line In (Light Blue)** | 11  | HDMI Port                    |
| 6   | Front Speaker (Lime)** | 12  | DVI-D Port                   |

\* There are two LEDs on each LAN port. Please refer to the table below for the LAN port LED indications.

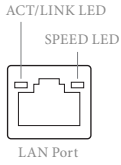

| Activity / Link LED |               | Speed LED |                    |
|---------------------|---------------|-----------|--------------------|
| Status              | Description   | Status    | Description        |
| Off                 | No Link       | Off       | 10Mbps connection  |
| Blinking            | Data Activity | Orange    | 100Mbps connection |
| On                  | Link          | Green     | 1Gbps connection   |

\*\* Function of the Audio Ports in 7.1-channel Configuration:

| Port                    | Function                       |
|-------------------------|--------------------------------|
| Light Blue (Rear panel) | Rear Speaker Out               |
| Lime (Rear panel)       | Front Speaker Out              |
| Pink (Rear panel)       | Central /Subwoofer Speaker Out |
| Lime (Front panel)      | Side Speaker Out               |



# Chapter 1 Introduction

Thank you for purchasing ASRock H410M-HDVP / H410M-HDVP2 motherboard, a reliable motherboard produced under ASRock's consistently stringent quality control. It delivers excellent performance with robust design conforming to ASRock's commitment to quality and endurance.



*Because the motherboard specifications and the BIOS software might be updated, the content of this documentation will be subject to change without notice. In case any modifications of this documentation occur, the updated version will be available on ASRock's website without further notice. If you require technical support related to this motherboard, please visit our website for specific information about the model you are using. You may find the latest VGA cards and CPU support list on ASRock's website as well. ASRock website <http://www.asrock.com>.*

## 1.1 Package Contents

- ASRock H410M-HDVP / H410M-HDVP2 Motherboard (Micro ATX Form Factor)
- ASRock H410M-HDVP / H410M-HDVP2 Quick Installation Guide
- ASRock H410M-HDVP / H410M-HDVP2 Support CD
- 2 x Serial ATA (SATA) Data Cables (Optional)
- 1 x Screw for M.2 Socket (Optional)
- 1 x I/O Panel Shield

## 1.2 Specifications

- Platform**
- Micro ATX Form Factor
  - Solid Capacitor design

- CPU**
- Supports 10<sup>th</sup> Gen Intel® Core™ Processors (Socket 1200)
  - Digi Power design
  - 7 Power Phase design
  - Supports Intel® Turbo Boost Max 3.0 Technology

- Chipset**
- Intel® H410

- Memory**
- Dual Channel DDR4 Memory Technology
  - 2 x DDR4 DIMM Slots
  - Supports DDR4 2933/2800/2666/2400/2133 non-ECC, unbuffered memory
- \* Please refer to Memory Support List on ASRock's website for more information. (<http://www.asrock.com/>)
- \* Core™ (i9/i7) support DDR4 up to 2933; Core™ (i5/i3), Pentium® and Celeron® support DDR4 up to 2666.
- Supports ECC UDIMM memory modules (operate in non-ECC mode)
  - Max. capacity of system memory: 64GB
  - Supports Intel® Extreme Memory Profile (XMP) 2.0
  - 15μ Gold Contact in DIMM Slots

- Expansion Slot**
- 1 x PCI Express 3.0 x16 Slot
- \* Supports NVMe SSD as boot disks
- 2 x PCI Express 3.0 x1 Slots
  - 1 x PCI Slot

- Graphics**
- Intel® UHD Graphics Built-in Visuals and the VGA outputs can be supported only with processors which are GPU integrated.
  - Hardware Accelerated Codecs: AVC/H.264, HEVC/H.265 8bit, HEVC/H.265 10bit, VP8, VP9 8bit, VP9 10bit, MPEG 2, MJPEG, VC-1
- \* VP9 10bit and VC-1 are for decode only.
- \* VP8 and VP9 encode are not supported by Windows OS.

- Graphics, Media & Compute: Microsoft DirectX 12, OpenGL 4.5, Intel® Built In Visuals, Intel® Quick Sync Video, Hybrid / Switchable Graphics, OpenCL 2.1
  - Display & Content Security: Rec. 2020 (Wide Color Gamut), Microsoft PlayReady 3.0, Intel® SGX Content Protection, UHD/HDR Blu-ray Disc
  - Three graphics output options: D-Sub, DVI-D and HDMI
- \* Supports up to 2 displays simultaneously
- Supports HDMI 1.4 with max. resolution up to 4K x 2K (4096x2160) @ 30Hz
  - Supports DVI-D with max. resolution up to 1920x1200 @ 60Hz
  - Supports D-Sub with max. resolution up to 1920x1200 @ 60Hz
  - Supports Auto Lip Sync, Deep Color (12bpc), xvYCC and HBR (High Bit Rate Audio) with HDMI 1.4 Port (Compliant HDMI monitor is required)
  - Supports HDCP 2.3 with DVI-D and HDMI 1.4 Ports
  - Supports 4K Ultra HD (UHD) playback with HDMI 1.4 Port

#### Audio

- 7.1 CH HD Audio (Realtek ALC887 Audio Codec)
- Supports Surge Protection

#### LAN

- PCIE x1 Gigabit LAN 10/100/1000 Mb/s
- Realtek RTL8111GN
- Supports Wake-On-LAN
- Supports Lightning/ESD Protection
- Supports Energy Efficient Ethernet 802.3az
- Supports PXE

#### Rear Panel I/O

- 1 x PS/2 Mouse Port
- 1 x PS/2 Keyboard Port
- 1 x Serial Port: COM2
- 1 x D-Sub Port
- 1 x DVI-D Port
- 1 x HDMI Port
- 4 x USB 2.0 Ports (Supports ESD Protection) (**H410M-HDVP**)
- 2 x USB 2.0 Ports (Supports ESD Protection) (**H410M-HDVP2**)

- 2 x USB 3.2 Gen1 Ports (Supports ESD Protection)
- 1 x RJ-45 LAN Port with LED (ACT/LINK LED and SPEED LED)
- HD Audio Jacks: Line in / Front Speaker / Microphone

### Storage

- 4 x SATA3 6.0 Gb/s Connectors, support NCQ, AHCI and Hot Plug\*
- \* If M2\_1 is occupied by a SATA-type M.2 device, SATA3\_3 will be disabled.
- 1 x M.2 Socket (M2\_1), supports M Key type 2230/2242/2260/2280 M.2 SATA3 6.0 Gb/s module and M.2 PCI Express module up to Gen3 x2 (16 Gb/s)\*\*
- \*\* Supports NVMe SSD as boot disks
- \*\* Supports ASRock U.2 Kit

### Connector

- 1 x Print Port Header
- 1 x COM Port Header
- 1 x SPI TPM Header
- 1 x Chassis Intrusion and Speaker Header
- 1 x CPU Fan Connector (4-pin)
- \* The CPU Fan Connector supports the CPU fan of maximum 1A (12W) fan power.
- 1 x Chassis Fan Connector (4-pin)
- \* The Chassis Fan Connector supports the chassis fan of maximum 1A (12W) fan power.
- 1 x Chassis/Water Pump Fan Connector (4-pin) (Smart Fan Speed Control)
- \* The Chassis/Water Pump Fan supports the water cooler fan of maximum 2A (24W) fan power.
- \* CHA\_FAN1/WP can auto detect if 3-pin or 4-pin fan is in use.
- 1 x 24 pin ATX Power Connector
- 1 x 8 pin 12V Power Connector
- 1 x Front Panel Audio Connector
- 1 x USB 2.0 Header (Supports 2 USB 2.0 ports) (Supports ESD Protection) (**H410M-HDVP**)
- 2 x USB 2.0 Headers (Support 4 USB 2.0 ports) (Supports ESD Protection) (**H410M-HDVP2**)
- 1 x USB 3.2 Gen1 Header (Supports 2 USB 3.2 Gen1 ports) (Supports ESD Protection)

**BIOS  
Feature**

- AMI UEFI Legal BIOS with multilingual GUI support
- ACPI 6.0 Compliant wake up events
- SMBIOS 2.7 Support
- CPU Core/Cache, GT, DRAM, VCCSA, PCH, VCCST Voltage Multi-adjustment

**Hardware  
Monitor**

- Temperature Sensing: CPU, Chassis, Chassis/Water Pump Fans
- Fan Tachometer: CPU, Chassis, Chassis/Water Pump Fans
- Quiet Fan (Auto adjust chassis fan speed by CPU temperature): CPU, Chassis, Chassis/Water Pump Fans
- Fan Multi-Speed Control: CPU, Chassis, Chassis/Water Pump Fans
- CASE OPEN detection
- CPU Core, DRAM, PCH, VCCSA Voltage Multi-adjustment

**OS**

- Microsoft® Windows® 10 64-bit

**Certifica-  
tions**

- FCC, CE
- ErP/EuP ready (ErP/EuP ready power supply is required)

\* For detailed product information, please visit our website: <http://www.asrock.com>



*Please realize that there is a certain risk involved with overclocking, including adjusting the setting in the BIOS, applying Untied Overclocking Technology, or using third-party overclocking tools. Overclocking may affect your system's stability, or even cause damage to the components and devices of your system. It should be done at your own risk and expense. We are not responsible for possible damage caused by overclocking.*

---

## Chapter 2 Installation

This is a Micro ATX form factor motherboard. Before you install the motherboard, study the configuration of your chassis to ensure that the motherboard fits into it.

### Pre-installation Precautions

Take note of the following precautions before you install motherboard components or change any motherboard settings.

- Make sure to unplug the power cord before installing or removing the motherboard components. Failure to do so may cause physical injuries and damages to motherboard components.
- In order to avoid damage from static electricity to the motherboard's components, NEVER place your motherboard directly on a carpet. Also remember to use a grounded wrist strap or touch a safety grounded object before you handle the components.
- Hold components by the edges and do not touch the ICs.
- Whenever you uninstall any components, place them on a grounded anti-static pad or in the bag that comes with the components.
- When placing screws to secure the motherboard to the chassis, please do not over-tighten the screws! Doing so may damage the motherboard.

## 2.1 Installing the CPU



1. Before you insert the 1200-Pin CPU into the socket, please check if the **PnP cap** is on the socket, if the CPU surface is unclean, or if there are any **bent pins** in the socket. Do not force to insert the CPU into the socket if above situation is found. Otherwise, the CPU will be seriously damaged.
2. Unplug all power cables before installing the CPU.

1

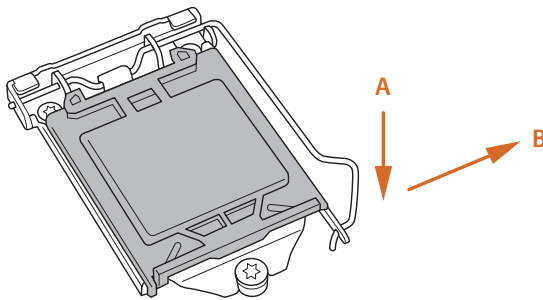

2

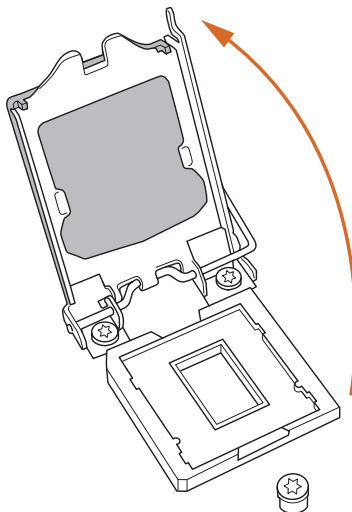

3

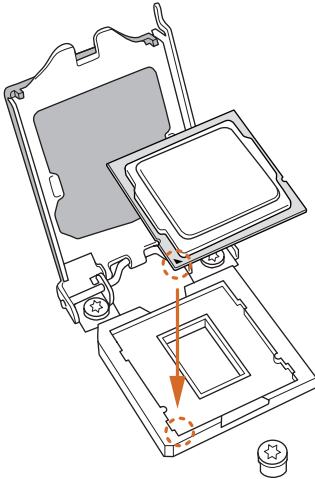

4

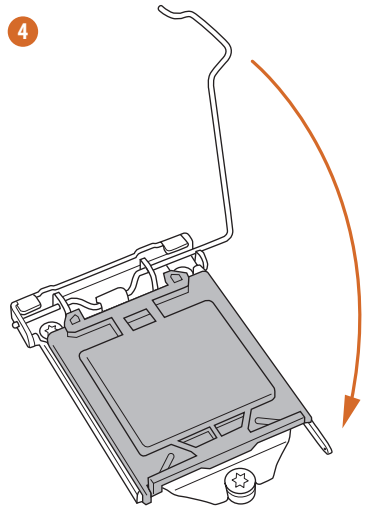

5

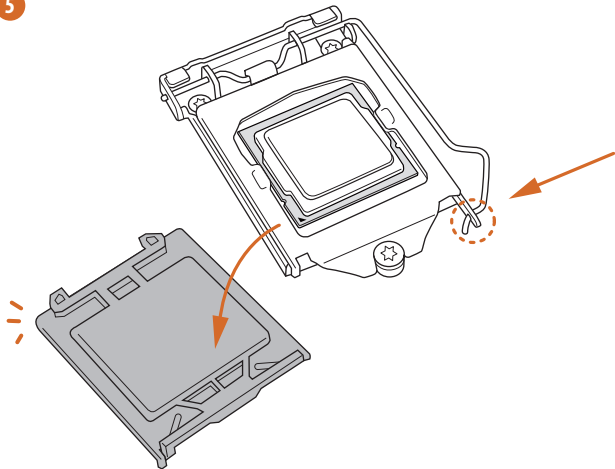

*Please save and replace the cover if the processor is removed. The cover must be placed if you wish to return the motherboard for after service.*



## 2.2 Installing the CPU Fan and Heatsink

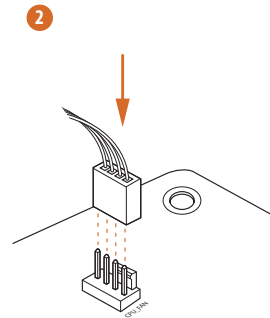
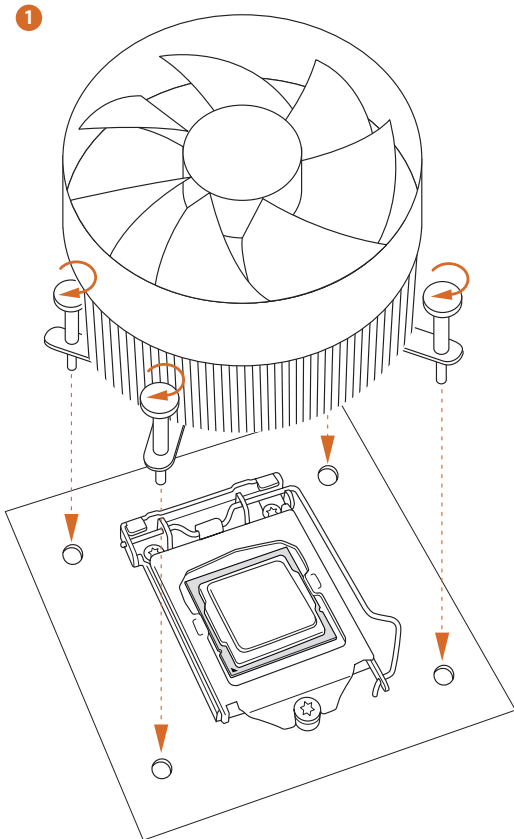
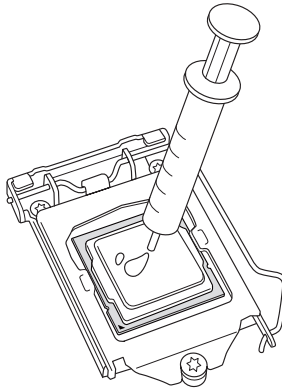

## 2.3 Installing Memory Modules (DIMM)

This motherboard provides two 288-pin DDR4 (Double Data Rate 4) DIMM slots, and supports Dual Channel Memory Technology.



1. For dual channel configuration, you always need to install identical (the same brand, speed, size and chip-type) DDR4 DIMM pairs.
2. It is unable to activate Dual Channel Memory Technology with only one memory module installed.
3. It is not allowed to install a DDR, DDR2 or DDR3 memory module into a DDR4 slot; otherwise, this motherboard and DIMM may be damaged.



The DIMM only fits in one correct orientation. It will cause permanent damage to the motherboard and the DIMM if you force the DIMM into the slot at incorrect orientation.

1

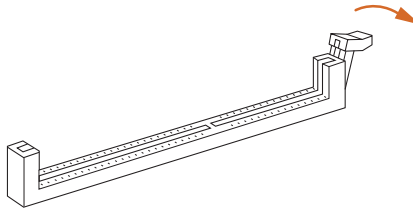

2

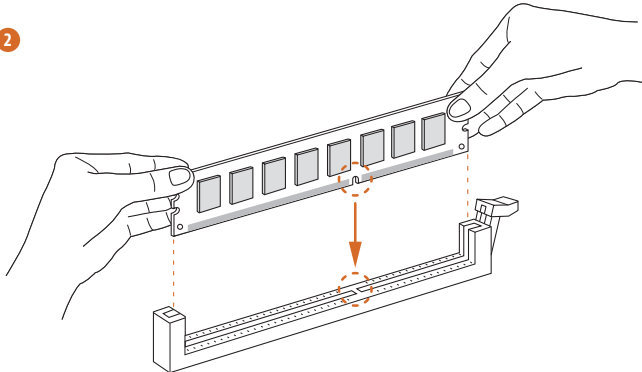

3

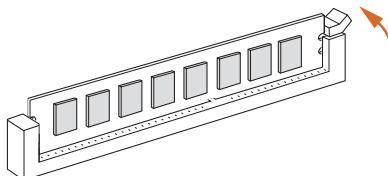

## 2.4 Expansion Slots (PCI and PCI Express Slots)

There are 1 PCI slot and 3 PCI Express slots on the motherboard.



*Before installing an expansion card, please make sure that the power supply is switched off or the power cord is unplugged. Please read the documentation of the expansion card and make necessary hardware settings for the card before you start the installation.*

### **PCI slot:**

The PCI1 slot is used to install expansion cards that have 32-bit PCI interface.

### **PCIe slots:**

PCIE1 (PCIe 3.0 x16 slot) is used for PCI Express x16 lane width graphics cards.

PCIE2 (PCIe 3.0 x1 slot) is used for PCI Express x1 lane width cards.

PCIE3 (PCIe 3.0 x1 slot) is used for PCI Express x1 lane width cards.

## 2.5 Jumpers Setup

The illustration shows how jumpers are setup. When the jumper cap is placed on the pins, the jumper is “Short”. If no jumper cap is placed on the pins, the jumper is “Open”.

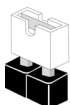

Short



Open

Clear CMOS Jumper  
(CLRMO51)  
(see p.1, 3, No. 10)



2-pin Jumper

Short: Clear CMOS  
Open: Default

CLRMO51 allows you to clear the data in CMOS. The data in CMOS includes system setup information such as system password, date, time, and system setup parameters. To clear and reset the system parameters to default setup, please turn off the computer and unplug the power cord, then use a jumper cap to short the pins on CLRMO51 for 3 seconds. Please remember to remove the jumper cap after clearing the CMOS. If you need to clear the CMOS when you just finish updating the BIOS, you must boot up the system first, and then shut it down before you do the clear-CMOS action.



*If you clear the CMOS, the case open may be detected. Please adjust the BIOS option “Clear Status” to clear the record of previous chassis intrusion status.*

## 2.6 Onboard Headers and Connectors



Onboard headers and connectors are NOT jumpers. Do NOT place jumper caps over these headers and connectors. Placing jumper caps over the headers and connectors will cause permanent damage to the motherboard.

System Panel Header  
(9-pin PANEL1)  
(see p.1, 3, No. 11)

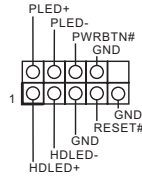

Connect the power button, reset button and system status indicator on the chassis to this header according to the pin assignments below. Note the positive and negative pins before connecting the cables.



**PWRBTN (Power Button):**

Connect to the power button on the chassis front panel. You may configure the way to turn off your system using the power button.

**RESET (Reset Button):**

Connect to the reset button on the chassis front panel. Press the reset button to restart the computer if the computer freezes and fails to perform a normal restart.

**PLED (System Power LED):**

Connect to the power status indicator on the chassis front panel. The LED is on when the system is operating. The LED keeps blinking when the system is in S1/S3 sleep state. The LED is off when the system is in S4 sleep state or powered off (S5).

**HDLED (Hard Drive Activity LED):**

Connect to the hard drive activity LED on the chassis front panel. The LED is on when the hard drive is reading or writing data.

The front panel design may differ by chassis. A front panel module mainly consists of power button, reset button, power LED, hard drive activity LED, speaker and etc. When connecting your chassis front panel module to this header, make sure the wire assignments and the pin assignments are matched correctly.

Chassis Intrusion and  
Speaker Header  
(7-pin SPK\_CI1)  
(see p.1, No. 15 or p.3, No.  
16)

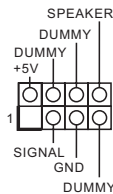

Please connect the chassis intrusion and the chassis speaker to this header.

### Serial ATA3 Connectors

(SATA3\_0:  
see p.1, 3, No. 8)  
(SATA3\_1:  
see p.1, 3, No. 9)  
(SATA3\_2:  
see p.1, 3, No. 7)  
(SATA3\_3:  
see p.1, 3, No. 6)



These four SATA3 connectors support SATA data cables for internal storage devices with up to 6.0 Gb/s data transfer rate.

\* If M2\_1 is occupied by a SATA-type M.2 device, SATA3\_3 will be disabled.

### USB 2.0 Headers

(9-pin USB\_4\_5)  
(see p.1, No. 14 or p.3, No. 15)  
(9-pin USB\_6\_7)  
(see p.3, No. 14)

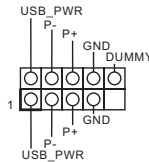

There is one header on H410M-HDVP and two headers on H410M-HDVP2. Each USB 2.0 header can support two ports.

### USB 3.2 Gen1 Header

(19-pin USB3\_2\_3)  
(see p.1, 3, No. 5)

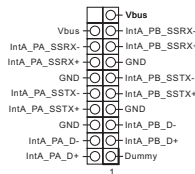

There is one header on this motherboard. This USB 3.2 Gen1 header can support two ports.

### Front Panel Audio Header

(9-pin HD\_AUDIO1)  
(see p.1, No. 19 or p.3, No. 20)

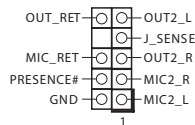

This header is for connecting audio devices to the front audio panel.



1. High Definition Audio supports Jack Sensing, but the panel wire on the chassis must support HDA to function correctly. Please follow the instructions in our manual and chassis manual to install your system.
2. If you use an AC'97 audio panel, please install it to the front panel audio header by the steps below:
  - A. Connect Mic\_IN (MIC) to MIC2\_L.
  - B. Connect Audio\_R (RIN) to OUT2\_R and Audio\_L (LIN) to OUT2\_L.
  - C. Connect Ground (GND) to Ground (GND).
  - D. MIC\_RET and OUT\_RET are for the HD audio panel only. You don't need to connect them for the AC'97 audio panel.
  - E. To activate the front mic, go to the "FrontMic" Tab in the Realtek Control panel and adjust "Recording Volume".

Chassis/Water Pump Fan Connector  
(4-pin CHA\_FAN1/WP)  
(see p.1, No. 18 or p.3, No. 19)

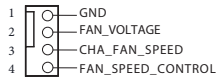

This motherboard provides one 4-Pin water cooling chassis fan connector. If you plan to connect a 3-Pin chassis water cooler fan, please connect it to Pin 1-3.

Chassis Fan Connector  
(4-pin CHA\_FAN2)  
(see p.1, 3, No. 12)

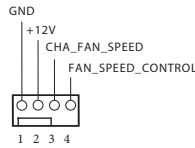

Please connect fan cables to the fan connector and match the black wire to the ground pin.

CPU Fan Connector  
(4-pin CPU\_FAN1)  
(see p.1, 3, No. 2)

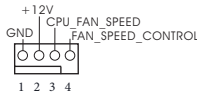

This motherboard provides a 4-Pin CPU fan (Quiet Fan) connector. If you plan to connect a 3-Pin CPU fan, please connect it to Pin 1-3.

ATX Power Connector  
(24-pin ATXPWR1)  
(see p.1, 3, No. 4)

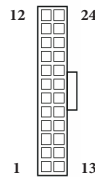

This motherboard provides a 24-pin ATX power connector. To use a 20-pin ATX power supply, please plug it along Pin 1 and Pin 13.

ATX 12V Power Connector  
(8-pin ATX12V1)  
(see p.1, 3, No. 1)

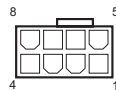

This motherboard provides a 8-pin ATX 12V power connector. To use a 4-pin ATX power supply, please plug it along Pin 1 and Pin 5.

**\*Warning: Please make sure that the power cable connected is for the CPU and not the graphics card. Do not plug the PCIe power cable to this connector.**

SPI TPM Header  
(13-pin SPI\_TPM\_J1)  
(see p.1, 3, No. 13)

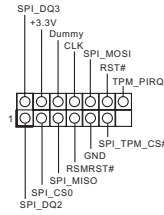

This connector supports SPI Trusted Platform Module (TPM) system, which can securely store keys, digital certificates, passwords, and data. A TPM system also helps enhance network security, protects digital identities, and ensures platform integrity.

Serial Port Header  
(9-pin COM2)  
(see p.1, No. 17 or p.3, No. 18)

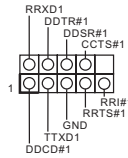

This COM2 header supports a serial port module.

Print Port Header  
(25-pin LPT1)  
(see p.1, No. 16 or p.3, No. 17)

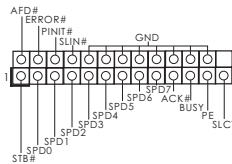

This is an interface for print port cable that allows convenient connection of printer devices.

## 2.7 M.2\_SSD (NGFF) Module Installation Guide

The M.2, also known as the Next Generation Form Factor (NGFF), is a small size and versatile card edge connector that aims to replace mPCIe and mSATA. The M.2 Socket (M2\_1) supports M Key type 2230/2242/2260/2280 M.2 SATA3 6.0 Gb/s module and M.2 PCI Express module up to Gen3 x2 (16 Gb/s).

\* If M2\_1 is occupied by a SATA-type M.2 device, SATA3\_3 will be disabled.

Please refer to our user manual for details of M.2 module installation guide. For the latest updates of the support list, please visit our website: <http://www.asrock.com>



## Technische Daten

- Plattform**
- Micro-ATX-Formfaktor
  - Feststoffkondensator-Design

- Prozessor**
- Unterstützt Intel® Core™-Prozessoren (Sockel 1200) der 10<sup>ten</sup> Generation
  - Digi Power design
  - 7-Leistungsphasendesign
  - Unterstützt Intel® Turbo Boost Max Technology 3.0

- Chipsatz**
- Intel® H410

- Speicher**
- Dualkanal-DDR4-Speichertechnologie
  - 2 x DDR4-DIMM-Steckplätze
  - Unterstützt ungepufferten DDR4 2933/2800/2666/2400/2133-Non-ECC-Speicher

\* Weitere Informationen finden Sie in der Speicherkompatibilitätsliste auf der ASRock-Webseite. (<http://www.asrock.com/>)

\* Core™ (i9/i7) Unterstützt DDR4 bis zu 2933; Core™ (i5/i3), Pentium® und Celeron® Unterstützt DDR4 bis zu 2666.

- Unterstützt ECC-UDIMM-Speichermodule (Betrieb im non-ECC-Modus)
- Systemspeicher, max. Kapazität: 64GB
- Unterstützt Intel® Extreme Memory Profile (XMP) 2.0
- 15-µ-Goldkontakt in DIMM-Steckplätze

- Erweiterungssteckplatz**
- 1 x PCI-Express 3.0-x16-Steckplatz
- \* Unterstützt NVMe-SSD als Bootplatte
- 2 x PCI-Express-3.0-x1-Steckplatz
  - 1 x PCI-Steckplatz

- Grafikkarte**
- Integrierte Intel® UHD Graphics-Visualisierung und VGA-Ausgänge können nur mit Prozessoren unterstützt werden, die GPU-integriert sind.
  - Hardware-beschleunigende Codecs: AVC/H.264, HEVC/H.265 8 bit, HEVC/H.265 10 bit, VP8, VP9 8 bit, VP9 10 bit, MPEG2, MJPEG, VC-1
- \* VP9 10 Bit und VC-1 dienen nur der Dekodierung.
- \* VP8- und VP9-Enkodierung werden von Windows-Betriebssystemen nicht unterstützt.

- Grafik, Medien und Rechenleistung: Microsoft DirectX 12, OpenGL 4.5, Intel® Built In Visuals, Intel® Quick Sync Video, Hybrid- / umschaltbare Grafikkarte, OpenCL 2.1
- Display & Content Security: Rec. 2020 (breiter Farbraum), Microsoft PlayReady 3.0, Intel® SGX-Inhaltsschutz, UHD/HDR Blu-ray Disc
- Drei Grafikkarten-Ausgangsoptionen: D-Sub, DVI-D und HDMI
- \* Unterstützt bis zu 2 Displays gleichzeitig
- Unterstützt HDMI 1.4 mit maximaler Auflösung von 4K x 2K (4096 x 2160) bei 30Hz
- Unterstützt DVI-D mit maximaler Auflösung von 1920 x 1200 bei 60 Hz
- Unterstützt D-Sub mit maximaler Auflösung von 1920 x 1200 bei 60 Hz
- Unterstützt Auto-Lippensynchronizität, hohe Farbtiefe (12 bpc), xvYCC und HBR (Audio mit hoher Bitrate) mit HDMI 1.4-Port (konformer HDMI-Monitor erforderlich)
- Unterstützt HDCP 2.3 mit DVI-D- und HDMI 1.4-Ports
- Unterstützt 4K-Ultra-HD- (UHD) Wiedergabe mit HDMI 1.4-Port

#### Audio

- 7.1-Kanal-HD-Audio (Realtek ALC887-Audiocodec)
- Unterstützt Überspannungsschutz

#### LAN

- PCIE-x1-Gigabit-LAN 10/100/1000 Mb/s
- Realtek RTL8111GN
- Unterstützt Wake-On-LAN
- Unterstützt Schutz gegen Blitzschlag/elektrostatische Entladung
- Unterstützt energieeffizientes Ethernet 802.3az
- Unterstützt PXE

#### Rückblende, E/A

- 1 x PS/2-Mausanschluss
- 1 x PS/2-Tastaturanschluss
- 1 x Serieller Port COM1
- 1 x D-Sub-Port
- 1 x DVI-D-Port
- 1 x HDMI-Port
- 4 x USB-2.0-Ports (unterstützt Schutz gegen elektrostatische Entladung) (**H410M-HDVP**)
- 2 x USB-2.0-Ports (unterstützt Schutz gegen elektrostatische Entladung) (**H410M-HDVP2**)

- 2 x USB-3.2-Gen1-Ports (unterstützt Schutz gegen elektrostatische Entladung)
- 1 x RJ-45-LAN-Port mit LED (Aktivität/Verbindung-LED und Geschwindigkeit-LED)
- HD-Audioanschlüsse: Line-in / Vorderer Lautsprecher / Mikrofon

### Speicher

- 4 x SATA-III-6,0-Gb/s-Anschlüsse, unterstützt NCQ, AHCI und Hot-Plugging\*

\* Wenn M2\_1 durch ein SATA-Typ-M.2-Gerät belegt ist, wird SATA3\_3 deaktiviert.

- 1 x M.2-Sockel (M2\_1), unterstützt M-Key-Typ-2230-/2242-/2260-/2280-M.2-SATA-III-6,0-Gb/s-Modul und M.2-PCI-Express-Modul bis Gen3 x 2 (16 Gb/s)\*\*

\*\* Unterstützt NVMe-SSD als Bootplatte

\*\* Unterstützt ASRock U.2-Kit

### Anschluss

- 1 x Druckerport-Anschlussleiste
- 1 x COM-Anschluss-Stiftleiste
- 1 x SPI-TPM-Stiftleiste
- 1 x Gehäuseeingriff- und Lautsprecher-Stiftleiste
- 1 x CPU-Lüfteranschluss (4-polig)

\* Der CPU-Lüfteranschluss unterstützt einen CPU-Lüfter mit einer maximalen Lüfterleistung von 1 A (12 W).

- 1 x Gehäuselüfteranschluss (4-polig)

\* Der Gehäuselüfteranschluss unterstützt einen Gehäuselüfter mit einer maximalen Lüfterleistung von 1 A (12 W).

- 1 x Anschluss Gehäuse/Wasserpumpenlüfter (4-polig) (intelligente Lüftergeschwindigkeitssteuerung)

\* Der Gehäuse-/Wasserpumpenlüfter unterstützt einen

Wasserkühlerlüfter mit einer maximalen Lüfterleistung von 2 A (24 W).

\* CHA\_FAN1/WP können automatisch erkennen, ob ein 3- oder 4-poliger Lüfter verwendet wird.

- 1 x 24-poliger ATX-Netzanschluss
- 1 x 8-poliger 12-V-Netzanschluss
- 1 x Audioanschluss an Frontblende
- 1 x USB 2.0-Stiftleiste (unterstützt zwei USB 2.0-Ports) (unterstützt Schutz gegen elektrostatische Entladung) (**H410M-HDVP**)
- 2 x USB 2.0-Stiftleiste (unterstützt vier USB 2.0-Ports) (unterstützt Schutz gegen elektrostatische Entladung) (**H410M-HDVP2**)
- 1 x USB 3.2 Gen1-Stiftleiste (unterstützt zwei USB 3.2 Gen1-Ports) (unterstützt Schutz gegen elektrostatische Entladung)

### Betriebs- system

- Microsoft® Windows® 10, 64 Bit

## Spécifications

### Plateforme

- Facteur de forme Micro ATX
- Conception à condensateurs solides

### Processeur

- Prend en charge les processeurs 10<sup>ème</sup> génération Intel® Core™ (socket 1200)
- Digi Power design
- Alimentation à 7 phases
- Prend en charge la technologie Intel® Turbo Boost Max 3.0

### Chipset

- Intel® H410

### Mémoire

- Technologie mémoire double canal DDR4
- 2 x fentes DIMM DDR4
- Prend en charge les mémoires sans tampon non ECC DDR4 2933/2800/2666/2400/2133

\* Veuillez consulter la liste de prise en charge des mémoires sur le site Web d'ASRock pour de plus amples informations.

(<http://www.asrock.com/>)

\* Core™ (i9/i7) prend en charge DDR4 jusqu'à 2933; Core™ (i5/i3), Pentium® et Celeron® prend en charge DDR4 jusqu'à 2666.

- Prend en charge les modules mémoire UDIMM ECC (fonctionne en mode non-ECC)
- Capacité max. de la mémoire système : 64Go
- Prend en charge Intel® Extreme Memory Profile (XMP) 2.0
- Contacts dorés 15µ sur fentes DIMM

### Fente

#### d'expansion

- 1 x fente PCI Express 3.0 x16
- \* Prend en charge les SSD NVMe comme disques de démarrage
- 2 x fentes PCI Express 3.0 x1
- 1 x fente PCI

### Graphiques

- La technologie Intel® UHD Graphics Built-in Visuals et les sorties VGA sont uniquement prises en charge par les processeurs intégrant un contrôleur graphique.
- Codecs d'accélération matérielle : AVC/H.264, HEVC/H.265 8bit, HEVC/H.265 10bit, VP8, VP9 8bit, VP9 10bit, MPEG 2, MJPEG, VC-1

\* VP9 10 bits et VC-1 sont uniquement destinés au décodage.

\* L'encodage VP8 et VP9 n'est pas pris en charge par le système d'exploitation Windows.

- Graphismes, multimédia et calcul : Microsoft DirectX 12, OpenGL 4.5, Intel® Built In Visuals, Intel® Quick Sync Video, Hybrid Graphics / Basculement des graphismes, OpenCL 2.1
  - Affichage et sécurité du contenu : Rec. 2020 (large gamme de couleurs), Microsoft PlayReady 3.0, protection de contenu Intel® SGX, disque Blu-ray UHD/HDR
  - Trois options de sortie graphique : D-Sub, DVI-D et HDMI
- \* Prend en charge jusqu'à 2 écrans simultanément
- Prend en charge la technologie HDMI 1.4 avec résolution maximale de 4K x 2K (4096x2160) @ 30Hz
  - Prend en charge le mode DVI-D avec une résolution maximale de 1920x1200 @ 60Hz
  - Prend en charge le mode D-Sub avec une résolution maximale de 1920x1200 @ 60Hz
  - Prend en charge les technologies Auto Lip Sync, Deep Color (12bpc), xvYCC et HBR (High Bit Rate Audio) avec port HDMI 1.4 (un écran compatible HDMI est requis)
  - Prend en charge HDCP 2.3 via ports DVI-D et HDMI 1.4
  - Prend en charge la lecture 4K Ultra HD (UHD) avec le port HDMI 1.4

#### Audio

- Audio 7.1 CH HD (Codec audio Realtek ALC887)
- Prend en charge la protection contre les surtensions

#### Réseau

- PCIE x1 Gigabit LAN 10/100/1000 Mo/s
- Realtek RTL8111GN
- Prend en charge la fonction Wake-On-LAN
- Prend en charge la protection contre la foudre/les décharges électrostatiques
- Prend en charge la fonction d'économie d'énergie Ethernet 802.3az
- Prend en charge PXE

#### Connectique du panneau arrière

- 1 x port souris PS/2
- 1 x port clavier PS/2
- 1 x port série: COM1
- 1 x port D-Sub
- 1 x port DVI-D
- 1 x port HDMI
- 4 x ports USB 2.0 (Protection contre les décharges électrostatiques) (H410M-HDVP)
- 2 x ports USB 2.0 (Protection contre les décharges électrostatiques) (H410M-HDVP2)

- 2 x ports USB 3.2 Gen1 (Protection contre les décharges électrostatiques)
- 1 x port RJ-45 LAN avec LED (LED ACT/LIEN et LED VITESSE)
- Connecteurs jack audio HD : Entrée ligne / haut-parleur avant / microphone

### Stockage

- 4 x connecteurs SATA3 6,0 Go/s, compatibles avec les fonctions NCQ, AHCI et « Hot Plug »\*
- \* Si M2\_1 est occupé par un périphérique M.2 type SATA, SATA3\_3 est désactivé.
- 1 x socket M.2 (M2\_1), prend en charge les modules M.2 SATA3 6,0 Gb/s type 2230/2242/2260/2280 et M.2 PCI Express touche M jusqu'à Gen3 x2 (16 Gb/s)\*\*
- \*\* Prend en charge les SSD NVMe comme disques de démarrage
- \*\* Prend en charge le kit ASRock U.2

### Connecteur

- 1 x embase pour port d'impression
- 1 x embase pour port COM
- 1 x embase SPI TPM
- 1 x prise DEL d'alimentation et emplacement sur châssis
- 1 x connecteur pour ventilateur de CPU (4 broches)
- \* Le connecteur pour ventilateur de CPU prend en charge un ventilateur de CPU d'une puissance maximale de 1 A (12 W).
- 1 x connecteur pour ventilateur de châssis (4 broches)
- \* Le connecteur pour ventilateur de châssis prend en charge un ventilateur de châssis d'une puissance maximale de 1 A (12 W).
- 1 x connecteur pour ventilateur de châssis /pompe à eau (4 broches) (contrôle de vitesse de ventilateur intelligent)
- \* Le ventilateur de châssis /pompe à eau prend en charge un ventilateur de refroidisseur d'eau d'une puissance maximale de 2 A (24 W).
- \* CHA\_FAN1/WP peuvent détecter automatiquement si un ventilateur 3 broches ou 4 broches est utilisé.
- 1 x connecteur d'alimentation ATX 24 broches
- 1 x connecteur d'alimentation 12 V 8 broches
- 1 x connecteur audio panneau frontal
- 1 x embase USB 2.0 (2 ports USB 2.0 pris en charge) (Protection contre les décharges électrostatiques) (H410M-HDVP)
- 2 x embase USB 2.0 (4 ports USB 2.0 pris en charge) (Protection contre les décharges électrostatiques) (H410M-HDVP2)
- 1 x embase USB 3.2 Gen1 (2 ports USB 3.2 Gen1 pris en charge) (Protection contre les décharges électrostatiques)

### Système d'exploitation

- Microsoft® Windows® 10 64 bits

## Specifiche

### Piattaforma

- Fattore di forma Micro ATX
- Design condensatore solido

### CPU

- Supporta processori 10<sup>th</sup> Generation Intel® Core™ (Socket 1200)
- Digi Power design
- Potenza a 7 fasi
- Supporta la tecnologia Intel® Turbo Boost Max 3.0

### Chipset

- Intel® H410

### Memoria

- Tecnologia memoria DDR4 Dual Channel
  - 2 x alloggi DIMM DDR4
  - Supporto di memoria DDR4 2933/2800/2666/2400/2133 non-ECC, un-buffered
- \* Per maggiori informazioni fare riferimento all'elenco dei supporti di memoria sul sito di ASRock. (<http://www.asrock.com/>)
- \* Core™ (i9/i7) supporta DDR4 fino a 2933; Core™ (i5/i3), Pentium® e Celeron® supporta DDR4 fino a 2666.
- Supporta moduli di memoria ECC UDIMM (funziona in modalità non ECC)
  - Capacità max. della memoria di sistema: 64GB
  - Supporto di XMP (Extreme Memory Profile) Intel® 2.0
  - Contatti d'oro 15µ negli alloggi DIMM

### Alloggio

#### d'espansione

- 1 x PCI Express 3.0 x16 slot
- \* Supporto di SSD NVMe come disco d'avvio
- 2 x alloggi PCI Express 3.0 x1
  - 1 x slot PCI

### Grafica

- La videografica integrata della scheda video UHD Intel® e le uscite VGA possono essere supportate soltanto con processori con GPU integrata.
  - Codec con accelerazione hardware: AVC/H.264, HEVC/H.265 8-bit, HEVC/H.265 10-bit, VP8, VP9 8-bit, VP9 10-bit, MPEG2, MJPEG, VC-1
- \* VP9 10bit e VC-1 servono solo per la decodifica.
- \* La codifica VP8 e VP9 non è supportata dal sistema operativo Windows.

- Grafica, multimedialità e calcolo: Microsoft DirectX 12, OpenGL 4.5, Grafica integrata Intel®, Sincronizzazione video Intel® Quick, Grafica ibrida/commutabile, OpenCL 2.1
- Visualizzazione e sicurezza dei contenuti: Rec. 2020 (Ampia gamma di colori), Microsoft PlayReady 3.0, Protezione dei contenuti Intel® SGX, UHD/HDR Blu-ray Disc
- Tre opzioni di output grafico: D-Sub, DVI-D e HDMI
- \* Supporta fino a 2 display simultaneamente
- Supporta HDMI 1.4 con risoluzione massima fino a 4K x 2K (4096 x 2160) a 30Hz
- Supporta DVI-D con una risoluzione max. fino a 1920 x 1200 a 60 Hz
- Supporta D-Sub con una risoluzione max. fino a 1920 x 1200 a 60 Hz
- Supporto delle funzioni Auto Lip Sync, Deep Color (12bpc), xvYCC e HBR (High Bit Rate Audio) con porta HDMI 1.4 (è necessario un monitor compatibile HDMI)
- Supporto di HDCP 2.3 con le porte DVI-D e HDMI 1.4
- Supporto riproduzione 4K Ultra HD (UHD) sulla porta HDMI 1.4

#### **Audio**

- Audio HD 7.1 CH (codec audio Realtek ALC887)
- Supporta protezione da sovratensione

#### **LAN**

- 1 x PCIE LAN Gigabit 10/100/1000 Mb/s
- Realtek RTL8111GN
- Supporto WOL (Wake-On-LAN)
- Supporta protezione da fulmini/scariche elettrostatiche
- Supporto Energy Efficient Ethernet 802.3az
- Supporto PXE

#### **I/O pannello posteriore**

- 1 x porta mouse PS/2
- 1 x porta tastiera PS/2
- 1 x porta seriale: COM1
- 1 x porta D-Sub
- 1 x porta DVI-D
- 1 x porta HDMI
- 4 x porte USB 2.0 (supporto protezione da scariche elettrostatiche) (H410M-HDVP)
- 2 x porte USB 2.0 (supporto protezione da scariche elettrostatiche) (H410M-HDVP2)



- 2 x porte USB 3.2 Gen1 (supporto protezione da scariche elettrostatiche)
- 1 x porta LAN RJ-45 con LED (ACT/LINK LED e SPEED LED)
- Connettori audio HD: Ingresso linea / altoparlante frontale / microfono

#### Archiviazione

- 4 x connettori SATA3 6,0 Gb/s supportano NCQ, AHCI e Hot Plug\*
- \* Se M2\_1 è occupato da un dispositivo M.2 di tipo SATA, SATA3\_3 sarà disabilitato.
- 1 x Socket M.2 (M2\_1), supporta il modulo M.2 SATA3 6,0 Gb/s di tipo M Key 2230/2242/2260/2280 ed il modulo M.2 PCI Express fino a Gen3 x2 (16 Gb/s)\*\*
- \*\* Supporto di SSD NVMe come disco d'avvio
- \*\* Supporta kit ASRock U.2

#### Connettore

- 1 x connettore porta stampa
  - 1 x connettore porta COM
  - 1 x connettore SPI TPM
  - 1 x collegamento altoparlante e intrusione telaio
  - 1 x connettore ventola CPU (4-pin)
- \* Il connettore ventola CPU supporta ventole CPU con potenza massima di 1 A (12 W).
- 1 x Connettore ventola telaio (4-pin)
- \* Il connettore ventola telaio supporta ventole telaio con potenza massima di 1 A (12 W).
- 1 x connettore ventola chassis/ventola pompa dell'acqua (4 pin) (Controllo intelligente della velocità della ventola)
- \* La ventola Chassis/ventola pompa dell'acqua supporta ventole di sistemi di raffreddamento ad acqua di potenza massima di 2 A (24W).
- \* CHA\_FAN1WP sono in grado di rilevare se è in uso una ventola a 3 pin o 4 a pin.
- 1 x connettore alimentazione ATX 24 pin
  - 1 x connettore alimentazione 12 V 8-pin
  - 1 x connettore audio pannello frontale
  - 1 x connettore USB 2.0 (supporto di 2 porte USB 2.0) (supporto protezione da scariche elettrostatiche) (**H410M-HDVP**)
  - 2 x connettore USB 2.0 (supporto di 4 porte USB 2.0) (supporto protezione da scariche elettrostatiche) (**H410M-HDVP2**)
  - 1 x connettore USB 3.2 Gen1 (supporto di 2 porte USB 3.2 Gen1) (supporto protezione da scariche elettrostatiche)

#### SO

- Microsoft® Windows® 10 64 bit

## Especificaciones

- Plataforma**
- Factor de forma Micro ATX
  - Diseño de condensador sólido

- CPU**
- Compatible con la 10ª generación de procesadores Intel® Core™ (Socket 1200)
  - Digi Power design
  - Diseño de 7 fases de alimentación
  - Admite Intel® Turbo Boost Technology 3.0

- Conjunto de chips**
- Intel® H410

- Memoria**
- Tecnología de memoria DDR4 de doble canal
  - 2 x ranuras DIMM DDR4
  - Admite memoria DDR4 2933/2800/2666/2400/2133 no ECC, sin búfer
- \* Para obtener más información, consulte la lista de memorias compatibles en el sitio web de ASRock. (<http://www.asrock.com/>)
- \* Core™ (i9/i7) compatible con DDR4 de hasta 2933; Core™ (i5/i3), Pentium® y Celeron® compatible con DDR4 de hasta 2666.
- Admite módulos de memoria UDIMM ECC (funcionamiento en modo no ECC)
  - Capacidad máxima de memoria del sistema: 64GB
  - Admite Perfil de memoria extremo de Intel® (XMP) 2.0
  - Contacto 15µ Gold en ranuras DIMM

- Ranura de expansión**
- 1 ranura PCI Express 3.0 x16
- \* Admite unidad de estado sólido de NVMe como disco de arranque
- 2 x Ranuras PCI Express 3.0 x1
  - 1 x ranura PCI

- Gráficos**
- Intel® UHD Graphics Built-in Visuals y las salidas de VGA son compatibles únicamente con procesadores con GPU integrado.
  - Códecs acelerados por hardware: AVC/H.264, HEVC/H.265 8 bits, HEVC/H.265 10 bits, VP8, VP9 8 bits, VP9 10 bits, MPEG2, MJPEG, VC-1
- \* VP9 10 bits y VC-1 son solo para decodificación.
- \* El sistema operativo Windows no admite la codificación VP8 y VP9.

- Gráficos, Multimedia & Compute: Microsoft DirectX 12, OpenGL 4.5, Intel® Built In Visuals, Intel® Quick Sync Video, Hybrid/Switchable Graphics, OpenCL 2.1
- Seguridad de visualización y contenido: Rec. 2020 (gama de colores amplia), Microsoft PlayReady 3.0, protección de contenido Intel® SGX, disco Blu-ray UHD/HDR
- Tres opciones de salida de gráficos: D-Sub, DVI-D y HDMI
- \* Admite hasta 2 pantallas simultáneamente
- Compatible con HDMI 1.4 con una resolución máxima de 4K x 2K (4096x2160) a 30Hz
- Admite DVI-D con una resolución máxima de 1920x1200 a 60 Hz
- Admite D-Sub con una resolución máxima de 1920x1200 a 60 Hz
- Admite Sincronización automática entre audio y vídeo, color profundo (12 bpc), xvYCC y HBR (audio de alta tasa de bits) con puerto HDMI 1.4 (se necesita un monitor compatible con HDMI)
- Compatible con función HDCP 2.3 con puertos DVI-D y HDMI 1.4
- Admite reproducción 4K Ultra HD (UHD) con puerto HDMI 1.4

#### **Audio**

- 7.1 Audio CH HD (Código de audio Realtek ALC887)
- Admite protección contra sobretensiones

#### **LAN**

- PCIE x1 Gigabit LAN 10/100/1000 Mb/s
- Realtek RTL8111GN
- Admite la función Reactivación de LAN
- Admite protección contra rayos y descargas electrostáticas (ESD)
- Admite Ethernet 802.3az de eficiencia energética
- Admite PXE

#### **E/S en panel posterior**

- 1 x puerto de ratón PS/2
- 1 x puerto de teclado PS/2
- 1 Puerto serie: COM1
- 1 x puerto D-Sub
- 1 x puerto DVI-D
- 1 x puerto HDMI
- 4 x Puertos USB 2.0 (admite protección contra descargas electrostáticas) (**H410M-HDVP**)
- 2 x Puertos USB 2.0 (admite protección contra descargas electrostáticas) (**H410M-HDVP2**)

- 2 x Puertos USB 3.2 Gen1 (admite protección contra descargas electrostáticas)
- 1 x Puerto LAN RJ-45 con LED (LED DE ACTIVIDAD/ENLACE y LED DE VELOCIDAD)
- Conector de audio HD: Entrada de línea / Altavoz frontal / Micrófono

### Almacenamiento

- 4 x conectores SATA3 de 6,0 Gb/s, compatibles con las funciones NCQ, AHCI y Conexión en caliente\*
- \* Si M2\_1 se ocupa con un dispositivo M.2 de tipo SATA, SATA3\_3 se deshabilitará.
- 1 x Zócalo M.2 (M2\_1) que admite el módulo SATA3 6,0 Gb/s M.2 de tipo 2230/2242/2260/2280 con clave M y el módulo PCI Express M.2 hasta Gen3 x2 (16 Gb/s)\*\*
- \*\* Admite unidad de estado sólido de NVMe como disco de arranque
- \*\* Admite el kit U.2 de ASRock

### Conector

- 1 x Base de conexiones de puerto de impresión
- 1 x Base de conexiones de puerto COM
- 1 x Conector SPI TPM
- 1 x cabezal de intrusión de chasis y de altavoces
- 1 x Conector para ventilador de la CPU (4 contactos)
- \* El conector para ventilador de la CPU admite ventilador de la CPU con una potencia de ventilador de 1 A (12 W) máxima.
- 1 x Conector para ventilador del chasis (4 contactos)
- \* El conector para ventilador del chasis admite el ventilador del chasis con una potencia de ventilador máxima de 1 A (12 W).
- 1 x Conector (4 contactos) para el ventilador de la bomba de agua/chasis (control de velocidad de ventilador inteligente)
- \* El ventilador de la bomba de agua/Chasis admite ventilador del disipador por agua con una potencia de ventilador máxima de 2 A (24 W).
- \* CHA\_FAN1/WP se pueden detectar automáticamente si se usa el ventilador de 3 o 4 contactos.
- 1 x conector de alimentación ATX de 24 contactos
- 1 x conector de alimentación de 12V de 8 contactos
- 1 x Conector de audio en el panel frontal
- 1 x Base de conexiones USB 2.0 (admite 2 puertos USB 2.0). Admite protección contra descargas electrostáticas (H410M-HDVP)
- 2 x Base de conexiones USB 2.0 (admite 4 puertos USB 2.0). Admite protección contra descargas electrostáticas (H410M-HDVP2)
- 1 x base de conexiones USB 3.2 Gen1 (admite 2 puertos USB 3.2 Gen1) (Admite protección contra descargas electrostáticas)

### SO

- Microsoft® Windows® 10 64 bits

## Технические характеристики

|                               |  |
|-------------------------------|--|
| <b>Платформа</b>              | <ul style="list-style-type: none"> <li>• Форм-фактор Micro ATX</li> <li>• Схема на основе твердотельных конденсаторов</li> </ul>   |
| <b>ЦП</b>                     | <ul style="list-style-type: none"> <li>• Поддержка процессоров 10<sup>го</sup> поколения Intel® Core™ (Socket 1200)</li> <li>• Digi Power design</li> <li>• Система питания 7</li> <li>• Поддерживается технология Intel® Turbo Boost Max 3.0</li> </ul>   |
| <b>Чипсет</b>                 | <ul style="list-style-type: none"> <li>• Intel® H410</li> </ul>  |
| <b>Память</b>                 | <ul style="list-style-type: none"> <li>• Двухканальная память DDR4</li> <li>• 2 гнезда DDR4 DIMM</li> <li>• Поддерживаются модули небуферизованной памяти DDR4 2933/2800/2666/2400/2133 без ECC</li> </ul> <p>* Дополнительная информация представлена в Списке совместимой памяти (Memory Support List) на веб-сайте ASRock. (<a href="http://www.asrock.com/">http://www.asrock.com/</a>)</p> <p>* Core™ (i9/i7) поддерживают память DDR4 с частотой до 2933; Core™ (i5/i3), Pentium® и Celeron® поддерживают память DDR4 с частотой до 2666.</p> <ul style="list-style-type: none"> <li>• Поддержка модулей памяти ECC UDIMM (работа в режиме, отличном от ECC)</li> <li>• Максимальный объем ОЗУ: 64 Гб</li> <li>• Поддерживается Intel® Extreme Memory Profile (XMP) 2.0</li> <li>• Позолоченные (15 мкм) контакты слотов DIMM</li> </ul> |
| <b>Слоты расширения</b>       | <ul style="list-style-type: none"> <li>• 1 x PCI Express 3.0 x16 гнезд</li> </ul> <p>* Поддерживаются в качестве загрузочных SSD-диски типа NVMe</p> <ul style="list-style-type: none"> <li>• 2 слота PCI Express 3.0 x1</li> <li>• 1 слот PCI</li> </ul>  |
| <b>Графическая подсистема</b> | <ul style="list-style-type: none"> <li>• Встроенный видеоадаптер Intel® UHD Graphics и выходы VGA поддерживаются только при использовании ЦП со встроенными графическими процессорами.</li> <li>• Кодеки с аппаратным ускорением Hardware Accelerated Codecs: AVC/H.264, HEVC/H.265 8 бит, HEVC/H.265 10 бит, VP8, VP9 8 бит, VP9 10 бит, MPEG2, MJPEG, VC-1</li> </ul> <p>* VP9 10 бит и VC-1 только для декодирования.</p> <p>* Кодирование VP8 и VP9 не поддерживается ОС Windows.</p>  |

- Графика, мультимедиа и вычисления: Microsoft DirectX 12, OpenGL 4.5, Встроенные визуальные элементы Intel®, Intel® Quick Sync Video, Гибридная / переключаемая графика, OpenCL 2.1
- Отображение и безопасность содержания: Rec. 2020 (широкая цветовая гамма), Microsoft PlayReady 3.0, Защита содержания Intel® SGX, Диск UHD/HDR Blu-ray
- Три видеовыхода: D-Sub, DVI-D и HDMI
- \* Поддерживается вывод одновременно на 2 монитора
- Поддержка HDMI 1.4 с максимальным разрешением до 4К × 2К (4096x2160) при 30 Гц
- Поддерживается DVI-D с максимальным разрешением до 1920x1200 при 60 Гц
- Поддерживается D-Sub с максимальным разрешением до 1920x1200 при 60 Гц
- Поддерживаются Auto Lip Sync, Deep Color (12 бит/цвет), xvYCC и HBR (High Bit Rate Audio) через порт HDMI 1.4 (требуется соответствующий HDMI-монитор)
- Поддержка функции HDCP 2.3 через порты DVI-D и HDMI 1.4
- Поддержка вывода видео с разрешением 4K Ultra HD (UHD) на порт HDMI 1.4

**Звук**

- 7.1-канальный звук высокой четкости (аудиокодек Realtek ALC887)
- Защита от перепадов напряжения в электрической сети

**LAN**

- PCIE x1 Gigabit LAN 10/100/1000 Мбит/с
- Realtek RTL8111GN
- Поддерживается пробуждение по ЛВС
- Молниезащита и защита от электростатических разрядов
- Поддерживается Energy Efficient Ethernet 802.3az
- Поддерживается PXE

**Тыловые порты ввода-вывода**

- 1 порт PS/2 для мыши
- 1 порт PS/2 для клавиатуры
- 1 x Последовательный порт: COM1
- 1 порт D-Sub
- 1 порт DVI-D
- 1 порт HDMI
- 4 порта USB 2.0 (с защитой от электростатических разрядов) (H410M-HDVP)
- 2 порта USB 2.0 (с защитой от электростатических разрядов) (H410M-HDVP2)

- 2 портов USB 3.2 Gen1 (с защитой от электростатических разрядов)
- 1 порт ЛВС RJ-45 с индикаторами («Активность/Соединение» и «Скорость»)
- Разъемы HD Audio: линейный вход / фронтальные АС / микрофон

#### Запоминающие устройства

- 4 х порта SATA3 6,0 Гбит/с, поддерживаются NCQ, АНСИ и «горячая» замена\*
- \* Если слот M2\_1 занят устройством M.2 типа SATA, интерфейс SATA3\_3 будет отключен.
- 1 х слот M.2 (M2\_1), поддерживает модуль M.2 SATA3 типа 2230/2242/2260/2280 с пропускной способностью 6,0 Гбит/с и модуль M.2 PCI Express до версии Gen3 x2 (16 Гбит/с)\*\*
- \*\* Поддерживаются в качестве загрузочных SSD-диски типа NVMe
- \*\* Поддерживается комплект ASRock U.2.

#### Разъемы

- 1 колодка порта принтера
- 1 колодка COM-порта
- 1 колодка SPI TPM
- 1 колодка с разъемами датчика вскрытия корпуса и динамика
- 1 разъем для вентилятора охлаждения ЦП, 4-контактный
- \* Разъем процессорного вентилятора поддерживает вентилятор с потребляемым током не более 1 А (12 Вт).
- 1 разъем для корпусного вентилятора (4-контактный)
- \* Разъем корпусного вентилятора поддерживает вентилятор с потребляемым током не более 1 А (12 Вт).
- 1 разъем для корпусного вентилятора или водяной помпы (4-контактный) (смарт-регулятор скорости вентилятора)
- \* Разъем для корпуса корпусного вентилятора или водяной помпы поддерживает вентилятор с потребляемым током не более 2 А (24 Вт).
- \* Для разъемов CHA\_FAN1/WP автоматически определяется тип подключенного вентилятора: 3- или 4-контактный.
- 1 разъем питания ATX, 24-контактный
- 1 разъем питания 12 В, 8-контактный
- 1 аудиоразъем для передней панели
- 1 колодка USB 2.0 (2 порта USB 2.0 с защитой от электростатических разрядов) (H410M-HDVP)
- 2 колодка USB 2.0 (4 порта USB 2.0 с защитой от электростатических разрядов) (H410M-HDVP2)
- 1 колодка USB 3.2 Gen1 (2 порта USB 3.2 Gen1) (с защитой от электростатических разрядов)

#### Операционные системы

- Microsoft® Windows® 10 (64-разрядная)

## Especificações

- Plataforma**
- Micro ATX Form Factor
  - Design de condensador sólido

- CPU**
- Suporta 10ª Geração de Processadores Intel® Core™ (Soquete 1200)
  - Digi Power design
  - Design com 7 fases de alimentação
  - Suporta Tecnologia Intel® Turbo Boost Max 3.0

- Chipset**
- Intel® H410

- Memória**
- Tecnologia de memória DDR4 de dois canais
  - 2 x Slots DIMM DDR4
  - Suporta memória DDR4 2933/2800/2666/2400/2133, não ECC, sem memória intermédia
- \* Por favor, consulte a Lista de Suporte de Memória no site da ASRock para obter mais informação. (<http://www.asrock.com/>)
- \* Core™ (i9/i7) suporta DDR4 2933 por overlocking; Core™ (i5/i3), Pentium® e Celeron® suporta DDR4 2666 por overlocking.
- Suporta módulos de memória ECC UDIMM (opera em modo não-ECC)
  - Capacidade máxima da memória do sistema: 64GB
  - Suporta Extreme Memory Profile (XMP) 2.0 da Intel®
  - Contato em Ouro 15µ nos slots DIMM

- Slot de expansão**
- 1 x slots PCI Express 3.0 x16
- \* Suporta NVMe SSD nos discos de inicialização
- 2 x Slots PCI Express 3.0 x1
  - 1 x Slots PCI

- Gráficos**
- Os gráficos incorporados Intel® UHD e as saídas VGA só podem ser suportados com processadores com GPU integrada.
  - Codecs Acelerados de Hardware: AVC/H.264, HEVC/H.265 8bit, HEVC/H.265 10bit, VP8, VP9 8bit, VP9 10bit, MPEG 2, MJPEG, VC-1
- \* VP9 10bit e VC-1 são apenas para decodificação.
- \* Codificação VP8 e VP9 não são suportados pelo SO Windows.
- Gráficos, Mídia e Computador: Microsoft DirectX 12, OpenGL 4.5, Intel® Built In Visuals, Intel® Quick Sync Video, Hybrid / Switchable Graphics, OpenCL 2.1



- Visualização e Segurança do Conteúdo: Rec. 2020 (Wide Color Gamut), Microsoft PlayReady 3.0, Proteção Conteúdo SGX Intel®, Disco Blu-ray UHD/HDR
- Três opções de saída de gráficos: D-Sub, DVI-D e HDMI
- \* Suporta até 2 monitores simultaneamente
- Suporta HDMI 1.4 com resolução máx. até 4K x 2K (4096x2160) @ 30Hz
- Suporta DVI-D com resolução máxima de até 1920x1200 @ 60Hz
- Suporta D-Sub com resolução máxima de até 1920x1200 @ 60Hz
- Suporta Auto sincronização labial, Deep Color (12bpc), xvYCC e HBR (High Bit Rate Audio) com porta HDMI 1.4 (É necessário um monitor compatível com HDMI)
- Suporta HDCP 2.3 com Portas DVI-D e HDMI 1.4
- Suporta reprodução HD Ultra (UHD) 4K com Porta HDMI 1.4

#### Áudio

- Áudio 7.1 CH HD com proteção de conteúdo (Codec de áudio Realtek ALC887)
- Suporta Proteção de Sobretensão

#### LAN

- LAN Gigabit 10/100/1000 Mb/s PCIE x1
- Realtek RTL8111GN
- Suporta Wake-On-LAN
- Oferece Suporte à Proteção de Relâmpago/ESD
- Suporta Energy Efficient Ethernet 802.3az
- Suporta PXE

#### E/S do painel posterior

- 1 x Porta PS/2 para mouse
- 1 x Porta PS/2 para Teclado
- 1 x Porta Serial: COM1
- 1 x Porta D-Sub
- 1 x Porta DVI-D
- 1 x Porta HDMI
- 4 x Portas USB 2.0 (Suporta Proteção ESD) (**H410M-HDVP**)
- 2 x Portas USB 2.0 (Suporta Proteção ESD) (**H410M-HDVP2**)
- 2 x Portas USB 3.2 Gen1 (Suporta Proteção ESD)
- 1 x Porta LAN RJ-45 com LED (LED ACT/LINK e LED DE VELOCIDADE)
- Fichas de áudio HD: Entrada de Linha / Autofalante Frontal / Microfone

## Armazenamento

- 4 x Conectores SATA3 6,0 Gb/s, suporte NCQ, AHCI, Conector a Quente\*
- \* Se M2\_1 é ocupado por um dispositivo tipo M.2 SATA, SATA3\_3 será desativado.
- 1 x Soquete M.2 (M2\_1), suporta módulo M.2 SATA3 6,0 Gb/s chave M tipo 2230/2242/2260/2280 e módulo M.2 PCI Express até Gen3 x2 (16 Gb/s)\*\*
- \*\* Suporta NVMe SSD como discos de inicialização
- \*\* Suporta Kit ASRock U.2

## Conector

- 1 x Suporte Porta Impressão
  - 1 x Suporte porta COM
  - 1 x Plataforma SPI TPM
  - 1 x Intrusão do Chassi e Cabeçote de Autofalante
  - 1 x Conector da ventoinha da CPU (4 pinos)
  - \* O Conector do Ventilador de CPU suporta o ventilador de CPU de alimentação máxima 1A do ventilador (12W).
    - 1 x Conector da ventoinha do Gabinete (4 pinos)
  - \* O Conector do Ventilador do Chassi suporta o ventilador do chassi de potência do ventilador máxima de 1A (12W).
    - 1 x Conector do ventilador do chassi/Ventilador da Bomba de Água (4 pinos) (Controle de Velocidade de Ventoinha Inteligente)
  - \* O Ventilador de Chassi/Ventilador da Bomba de Água suporta o ventilador de refrigerador a água de 2A máximo (24W) potência do ventilador.
  - \* CHA\_FAN1/WP podem detectar automaticamente se ventoinha de 3 pinos ou 4 pinos está em uso.
    - 1 x Conector alimentação ATX 24 pinos
    - 1 x Conector de energia 8-pinos 12V
    - 1 x Conector de áudio do painel frontal
    - 1 x Plataforma USB 2.0 (Suporta 2 portas USB 2.0) (Suporta Proteção ESD) (**H410M-HDVP**)
    - 2 x Plataforma USB 2.0 (Suporta 4 portas USB 2.0) (Suporta Proteção ESD) (**H410M-HDVP2**)
    - 1 x Plataforma USB 3.2 Gen1 (Suporta 2 portas USB 3.2 Gen1) (Suporta Proteção ESD)
- SO**
- Microsoft® Windows® 10 64-bit

## Specyfikacje

### Platforma

- Współczynnik kształtu Micro ATX
- Konstrukcja kondensatorami stałymi

### CPU

- Obsługa 10<sup>ej</sup> Gen procesorów Intel® Core™ (Socket 1200)
- Digi Power design
- Sekcja zasilania 7 Power Phase Design
- Obsługa technologii Intel® Turbo Boost Max 3.0

### Chipset

- Intel® H410

### Pamięć

- Technologia pamięci Dual Channel DDR4
- 2 x gniazda DDR4 DIMM
- Obsługa pamięci DDR4 2933/2800/2666/2400/2133 non-ECC, pamięć niebuforowana
- \* Sprawdź listę obsługiwanej pamięci na stronie internetowej ASRock w celu uzyskania dalszych informacji. (<http://www.asrock.com/>)
- \* Core™ (i9/i7) obsługuje DDR4 do 2933; Core™ (i5/i3), Pentium® i Celeron® obsługuje DDR4 do 2666.
- Obsługa modułów pamięci ECC UDIMM (działanie w trybie non-ECC)
- Maks. wielkość pamięci systemowej: 64GB
- Obsługa Intel® Extreme Memory Profile (XMP) 2.0
- 15µm połączone styki w gniazdach DIMM

### Gniazdo rozszerzenia

- 1 x gniazdo PCI Express 3.0 x16
- \* Obsługa SSD NVMe, jako dysków rozruchowych
- 2 x gniazda PCI Express 3.0 x1
- 1 x gniazdo PCI

### Grafika

- Wbudowana grafika Intel® UHD i wyjścia VGA są obsługiwane wyłącznie z procesorami, które mają zintegrowane GPU.
- Sprzętowo przyspieszane kodeki: AVC/H.264, HEVC/H.265 8-bit, HEVC/H.265 10-bit, VP8, VP9 8-bit, VP9 10-bit, MPEG2, MJPEG, VC-1
- \* VP9 10bit i VC-1 służą wyłącznie do dekodowania.
- \* VP8 i VP9 kodowania nie są obsługiwane przez system operacyjny Windows.

- Grafika, Media i komputery: Microsoft DirectX 12, OpenGL 4.5, Intel® Built In Visuals, Intel® Quick Sync Video, Hybrid / Switchable Graphics, OpenCL 2.1
- Bezpieczeństwo wyświetlania i treści: Rec. 2020 (Wide Color Gamut), Microsoft PlayReady 3.0, Intel® SGX Content Protection, UHD/HDR Blu-ray Disc
- Opcje trzech wyjść graficznych: D-Sub, DVI-D i HDMI
- \* Obsługa do 2 monitorów jednocześnie
- Obsługa HDMI 1.4 z maks. rozdzielczością do 4K x 2K (4096x2160) przy 30Hz
- Obsługa DVI-D z maks. rozdzielczością do 1920x1200 przy 60Hz
- Obsługa D-Sub z maks. rozdzielczością do 1920x1200 przy 60Hz
- Obsługa Auto Lip Sync, Deep Color (12bpc), xvYCC i HBR (High Bit Rate Audio) z portami HDMI 1.4 (Wymagany monitor zgodny z HDMI)
- Obsługa HDCP 2.3 z portami DVI-D i HDMI 1.4
- Obsługa odtwarzania 4K Ultra HD (UHD) z portem HDMI 1.4

**Audio**

- Dźwięk HD 7.1 CH (kodek audio Realtek ALC887)
- Obsługa zabezpieczenia przed przepięciami

**LAN**

- 1 x PCIE Gigabit LAN 10/100/1000 Mb/s
- Realtek RTL8111GN
- Obsługa Wake-On-LAN
- Obsługa zabezpieczenia przed wyładowaniami atmosferycznymi/ESD
- Obsługa Energy Efficient Ethernet 802.3az
- Obsługa PXE

**Tylny panel****Wejścia/****Wyjścia**

- 1 x port myszy PS/2
- 1 x port klawiatury PS/2
- 1 x port szeregowy: COM1
- 1 x port D-Sub
- 1 x port DVI-D
- 1 x port HDMI
- 4 x porty USB 2.0 (obsługa zabezpieczenia ESD) (**H410M-HDVP**)
- 2 x porty USB 2.0 (obsługa zabezpieczenia ESD) (**H410M-HDVP2**)

- 2 x porty USB 3.2 Gen1 (Obsługa zabezpieczenia ESD)
- 1 x port LAN RJ-45 z LED (LED ACT/LINK i LED SPEED)
- Gniazda audio HD: Wejście liniowe / Głośnik przedni / Mikrofon

### Przechowywanie

- 4 x złącza SATA3 6,0 Gb/s, obsługa NCQ, AHCI i Hot Plug\*
- \* Jeśli gniazdo M2\_1 jest zajęte przez urządzenie M.2 typu SATA, zostanie wyłączone SATA3\_3.
- 1 x gniazdo Ultra M.2 (M2\_1), obsługa Key M typu 2230/2242/2260/2280 modułu M.2 SATA3 6,0 Gb/s i modułu M.2 PCI Express do Gen3 x2 (16 Gb/s)\*\*
- \*\* Obsługa SSD NVMe, jako dysków rozruchowych
- \*\* Obsługa ASRock U.2 Kit

### Złącze

- 1 x złącze główkowe portu drukarki
- 1 x złącze główkowe portu COM
- 1 x złącze główkowe SPI TPM
- 1 x złącze główkowe naruszenia obudowy i głośnika
- 1 x złącze wentylatora CPU (4-pinowe)
- \* Złącze wentylatora CPU obsługuje wentylator CPU maksymalnym prądem zasilania wentylatora 1A (12W).
- 1 x złącze wentylatora obudowy (4-pinowe)
- \* Złącze wentylatora obudowy obsługuje wentylator obudowy maksymalnym prądem zasilania wentylatora 1A (12W).
- 1 x złącza wentylatora obudowy/pompy wodnej (4-pinowe) (Inteligentne sterowanie prędkością obrotową wentylatora)
- \* Złącze wentylatora obudowy/pompy wodnej obsługuje wentylator układu chłodzenia maksymalnym prądem zasilania wentylatora 2A (24W).
- \* CHA\_FAN1/WP może automatycznie wykrywać, jeśli używany jest wentylator 3-pinowy lub 4-pinowy.
- 1 x 24 pinowe złącze zasilania ATX
- 1 x 8 pinowe złącze zasilania 12V
- 1 x złącze audio na panelu przednim
- 1 x złącza główkowe USB 2.0 (obsługuje 2 porty USB 2.0) (Obsługa zabezpieczenia ESD) (**H410M-HDVP**)
- 2 x złącza główkowe USB 2.0 (obsługuje 4 porty USB 2.0) (Obsługa zabezpieczenia ESD) (**H410M-HDVP2**)
- 1 x porty główkowe USB 3.2 Gen1 (obsługa 2 portów USB 3.2 Gen1) (obsługa zabezpieczenia ESD)

### System operacyjny

- Microsoft® Windows® 10 64-bitowy

## 규격

### 플랫폼

- Micro ATX 폼 팩터
- 솔리드 콘덴서 구조

### CPU

- 10 세대 Intel® Core™ 프로세서 지원 (소켓 1200)
- Digi Power design
- 7 개 전원 위상 구조
- Intel® Turbo Boost Max Technology 3.0 지원

### 칩세트

- Intel® H410

### 메모리

- 듀얼 채널 DDR4 메모리 기술
  - DDR4 DIMM 슬롯 2 개
  - DDR4 2933/2800/2666/2400/2133 비 ECC, 비버퍼링 메모리 지원
- \* 추가 정보를 원하시면 ASRock 웹사이트에 있는 메모리 지원 목록을 참조하십시오. (<http://www.asrock.com/>)
- \* Core™ (i9/i7) 는 최대 2933 까지 DDR4 를 지원하고 ; Core™ (i5/i3), Pentium® 및 Celeron® 는 최대 2666 까지 DDR4 를 지원하고 .
- ECC UDIMM 메모리 모듈 (비 -ECC 모드에서 작동함) 지원
  - 시스템 메모리 최대 용량 : 64GB
  - Intel® Extreme Memory Profile (XMP) 2.0 지원
  - DIMM 슬롯에 15μ Gold Contact 장착

### 확장 슬롯

- PCI Express 3.0 x16 슬롯 1 개
- \* NVMe SSD 를 부팅 디스크로 사용 가능하도록 지원
- PCI Express 3.0 x1 슬롯 2 개
  - PCI 슬롯 1 개

### 그래픽

- Intel® UHD 그래픽스 빌트 - 인 비주얼과 VGA 출력은 GPU 통합 프로세서로만 지원할 수 있습니다 .
  - 하드웨어 가속 코덱 : AVC/H.264, HEVC/H.265 8- 비트 , HEVC/H.265 10- 비트 , VP8, VP9 8- 비트 , VP9 10- 비트 , MPEG2, MJPEG, VC-1
- \* VP9 10 비트 및 VC-1 는 디코딩 전용입니다 .
- \* VP8 및 VP9 인코딩은 Windows OS 에서 지원되지 않습니다 .
- 그래픽 , 미디어 & 컴퓨팅 : Microsoft DirectX 12, OpenGL 4.5, Intel® Built In Visuals, Intel® Quick Sync Video, Hybrid / Switchable Graphics, OpenCL 2.1

- 디스플레이 & 콘텐츠 보안 : Rec. 2020 (Wide Color Gamut), Microsoft PlayReady 3.0, Intel® SGX Content Protection, UHD/HDR 블루레이 디스크
- 그래픽 출력 옵션 세 개 : D-Sub, DVI-D 및 HDMI
- \* 최대 2 개의 디스플레이를 동시에 지원
  - HDMI 1.4 지원 ( 최대 해상도 4K x 2K (4096x2160) @ 30Hz)
  - DVI-D 지원 ( 최대 해상도 1920x1200 @ 60Hz)
  - D-Sub 지원 ( 최대 해상도 1920x1200 @ 60Hz)
  - Auto Lip Sync, Deep Color (12bpc), xvYCC 및 HBR (High Bit Rate Audio)(HDMI 1.4 포트 포함 ) 지원 (HDMI 호환 모니터 필요 )
  - DVI-D 및 HDMI 1.4 포트를 이용한 HDCP 2.3 지원
  - HDMI 1.4 포트를 이용한 4K Ultra HD(UHD) 재생 지원

#### 오디오

- 7.1 CH HD 오디오 (Realtek ALC887 오디오 코덱 )
- 서비 보호 지원

#### LAN

- PCIE 1 개 , Gigabit LAN 10/100/1000 Mb/s
- Realtek RTL8111GN
- Wake-On-LAN 지원
- 번개 /ESD 보호 지원
- 절전형 이더넷 802.3az 지원
- PXE 지원

#### 후면 패널 I/O

- PS/2 마우스 포트 1 개
- PS/2 키보드 포트 1 개
- 직렬 포트 1 개 COM1
- D-Sub 포트 1 개
- DVI-D 포트 1 개
- HDMI 포트 1 개
- USB 2 포트 4 개 (ESD 보호 지원 ) (H410M-HDVP)
- USB 2 포트 2 개 (ESD 보호 지원 ) (H410M-HDVP2)
- USB 3.2 Gen1 포트 2 개 (ESD 보호 지원 )
- LED 장착 RJ-45 LAN 포트 1 개 (ACT/LINK LED 및 SPEED LED)
- HD 오디오 잭 : 라인 입력 / 전면 스피커 / 마이크

## 저장 장치

- SATA3 6.0 Gb/s 커넥터 4 개, NCQ, AHCI 및 핫 플러그 지원 \*
- \* SATA- 타입 M.2 장치에서 M2\_1 을 사용 중이면, SATA3\_3 이 비활성화됩니다 .
- M.2 소켓 (M2\_1) 1 개, M 키 타입 2230/2242/2260/2280 M.2 SATA3 6.0 Gb/s 모듈 및 Gen3 M.2 PCI Express 모듈을 2 개 (16 Gb/s) 까지 지원 \*\*
- \*\* NVMe SSD 를 부팅 디스크로 사용 가능하도록 지원
- \*\* ASRock U.2 키트 지원

## 커넥터

- 인쇄 포트 헤더 1 개
- COM 포트 헤더 1 개
- SPI TPM 헤더 1 개
- 새시 침입 및 스피커 헤더 1 개
- CPU 팬 커넥터 (4 핀) 1 개
- \* CPU 팬 커넥터는 팬 전력이 최대 1A(12W) 인 CPU 팬을 지원합니다 .
- 새시 팬 커넥터 (4 핀) 1 개
- \* 새시 팬 커넥터는 팬 전력이 최대 1A(12W) 인 새시 팬을 지원합니다 .
- 새시 / 워터 펌프 팬 커넥터 (4 핀) 1 개 (스마트 팬 속도 제어)
- \* 새시 / 워터 펌프 팬은 팬 전력이 최대 2A(24W) 인 수냉식 쿨러 팬을 지원합니다 .
- \* 3 핀 또는 4 핀 팬이 사용 중인 경우, CHA\_FAN1/WP 가 자동으로 감지할 수 있습니다 .
- 24 핀 ATX 전원 커넥터 1 개
- 8 핀 12V 전원 커넥터 1 개
- 전면 패널 오디오 커넥터 1 개
- USB 2.0 헤더 1 개 (USB 2.0 포트 2 개 지원) (ESD 보호 지원) (**H410M-HDVP**)
- USB 2.0 헤더 2 개 (USB 2.0 포트 4 개 지원) (ESD 보호 지원) (**H410M-HDVP2**)
- USB 3.2 Gen1 헤더 1 개 (USB 3.2 Gen1 포트 2 개 지원) (ESD 보호 지원)

## OS

- Microsoft® Windows® 10 64- 비트



## 仕様

- プラットフォーム**
- マイクロ ATX フォームファクター
  - 固体コンデンサ設計

- CPU**
- 第 10 世代 Intel® Core™ プロセッサに対応(ソケット 1200)
  - デジタル電源設計
  - 7 電源フェーズ設計
  - Intel® ターボブースト Max テクノロジー 3.0 に対応

- チップセット**
- Intel® H410

- メモリ**
- デュアルチャンネル DDR4 メモリ機能
  - 2 x DDR4 DIMM スロット
  - DDR4 2933/2800/2666/2400/2133 ノン ECC、アンバッファードメモリに対応
- \* 詳細については、ASRock ウェブサイトのメモリーサポート一覧を参照してください。(http://www.asrock.com/)
- \* Core™ (i9/i7) は最大 2933 までの DDR4 に対応します ; Core™ (i5/i3), Pentium® および Celeron® は最大 2666 までの DDR4 に対応します。
- ECC UDIMM メモリモジュールに対応(non-ECC モードで動作)
  - システムメモリの最大容量: 64GB
  - Intel® エクストリームメモリプロファイル (XMP) 2.0 に対応
  - DIMM スロットに 15μ ゴールドコンタクトを採用

- 拡張スロット**
- 1 x PCI Express 3.0 x16 スロット
- \* 起動ディスクとして NVMe SSD に対応
- 2 x PCI Express 3.0 x1 スロット
  - 1 x PCI スロット

- グラフィックス**
- Intel® UHD グラフィックス内蔵ビジュアルおよび VGA 出力は、GPU に統合されたプロセッサのみでサポートされます。
  - ハードウェア・アクセラレイテッド・コーデック: AVC/H.264、HEVC/H.265 8- ビット、HEVC/H.265 10- ビット、VP8、VP9 8- ビット、VP9 10- ビット、MPEG2、MJPEG、VC-1
- \* VP9 10 ビットおよび VC-1 は、デコード用のみです。
- \* VP8 および VP9 エンコードは、Windows OS によりサポートされません。

- グラフィック、メディアおよびコンピュータ: Microsoft DirectX 12、OpenGL 4.5、インテル®ビルトイン・ビジュアル、インテル®クイック・シンク・ビデオ、ハイブリッド / スイッチャブル・グラフィックス、OpenCL 2.1
- ディスプレイおよびコンテンツのセキュリティ: Rec. 2020 (Wide Color Gamut)、Microsoft PlayReady 3.0、インテル® SGX コンテンツ保護、UHD/HDR Blu-ray ディスク
- 3つのグラフィックス出力オプション: D-Sub、DVI-D、HDMI
- \* 最大2台のディスプレイを同時に対応します
- HDMI 1.4 テクノロジーに対応、最大解像度 4K x 2K (4096x2160) @ 30Hz
- DVI-D に対応、最大解像度 1920x1200 @60Hz
- D-Sub に対応、最大解像度 1920x1200 @60Hz
- HDMI 1.4 ポートでオートリップシンク、ディープカラー (12bpc)、xvYCC、および、HBR (高ビットレートオーディオ) に対応 (HDMI 対応モニターが必要です)
- DVI-D ポートと HDMI 1.4 ポートで HDCP 2.3 に対応
- HDMI 1.4 ポートで 4K Ultra HD (UHD) 再生に対応

### オーディオ

- 7.1 CH HD オーディオ (Realtek ALC887 Audio Codec)
- サージ保護に対応

### LAN

- PCIE x1 ギガビット LAN 10/100/1000 Mb/ 秒
- Realtek RTL8111GN
- Wake-On-LAN (ウェイク オン ラン) に対応
- 雷 / 静電気放電 (ESD) 保護に対応
- エネルギー効率のよいイーサネット 802.3az をサポート
- PXE をサポート

### リアパネル I/O

- 1 x PS/2 マウスポート
- 1 x PS/2 キーボードポート
- 1 x シリアルポート: COM1
- 1 x D-Sub ポート
- 1 x DVI-D ポート
- 1 x HDMI ポート
- 4 x USB 2.0 ポート (静電気放電 (ESD) 保護に対応) (H410M-HDVP)
- 2 x USB 2.0 ポート (静電気放電 (ESD) 保護に対応) (H410M-HDVP2)
- 2 x USB 3.2 Gen1 ポート (静電気放電 (ESD) 保護に対応)
- LED 付き 1 x RJ-45 LAN ポート (ACT/LINK LED と SPEED LED)

- HD オーディオジャック: ラインイン / フロントスピーカー / マイク

## ストレージ

- 4 x SATA3 6.0 Gb/s コネクタ, NCQ, AHCI, および、ホットプラグ機能に対応 \*
- \* SATA タイプ M.2 デバイスで M2\_1 を使用している場合は、SATA3\_3 は無効になります。
- 1 x M.2 ソケット (M2\_1), M Key タイプ 2230/2242/2260/2280 M.2 SATA3 6.0 Gb/s モジュールと最大 Gen3 x2 (16 Gb/s) までの M.2 PCI Express モジュールに対応 \*\*
- \*\* 起動ディスクとして NVMe SSD に対応
- \*\* ASRock U.2 キットに対応

## コネクタ

- 1 x プリントポートヘッダー
- 1 x COM ポートヘッダー
- 1 x SPI TPM ヘッダー
- 1 x シャーシイントルージョンとスピーカーヘッダー
- 1 x CPU ファンコネクタ (4 ピン)
- \* CPU ファンコネクタは最大 1A (12W) の電力の CPU ファンに対応します。
- 1 x シャーシファンコネクタ (4 ピン)
- \* シャーシファンコネクタは最大 1A (12W) の出力のシャーシファンに対応します。
- 1 x シャーシ / ウォーターポンプファンコネクタ (4 ピン) (スマートファン速度制御)
- \* シャーシ / ウォーターポンプファンは最大 2A (24W) の出力のウォータークーラーに対応します。
- \* CHA\_FAN1/WP は 3 ピンまたは 4 ピンファンが使用されているかどうかを自動検出できます。
- 1 x 24 ピン ATX 電源コネクタ
- 1 x 8 ピン 12V 電源コネクタ
- 1 x 前面パネルオーディオコネクタ
- 1 x USB 2.0 ヘッダー (2 つの USB 2.0 ポートに対応) (静電気放電 (ESD) 保護に対応) (H410M-HDVP)
- 2 x USB 2.0 ヘッダー (4 つの USB 2.0 ポートに対応) (静電気放電 (ESD) 保護に対応) (H410M-HDVP2)
- 1 x USB 3.2 Gen1 ヘッダー (2 つの USB 3.2 Gen1 ポートに対応) (静電気放電 (ESD) 保護に対応)

## OS

- Microsoft® Windows® 10 64-bit

## 规格

|     |   |
|-----|---|
| 平台  | <ul style="list-style-type: none"> <li>• Micro ATX 规格尺寸</li> <li>• 稳固的电容器设计</li> </ul>  |
| CPU | <ul style="list-style-type: none"> <li>• 支持第 10 代 Intel® Core™ 处理器（插座 1200）</li> <li>• Digi Power design</li> <li>• 7 电源相设计</li> <li>• 支持 Intel® Turbo Boost Max Technology 3.0</li> </ul>  |
| 芯片集 | <ul style="list-style-type: none"> <li>• Intel® H410</li> </ul>   |
| 内存  | <ul style="list-style-type: none"> <li>• 双通道 DDR4 内存技术</li> <li>• 2 x DDR4 DIMM 槽</li> <li>• 支持 DDR4 2933/2800/2666/2400/2133 非 ECC，非缓冲内存</li> <li>* 请参阅华擎网站上的 Memory Support List（内存支持列表）了解详情。（<a href="http://www.asrock.com/">http://www.asrock.com/</a>）</li> <li>* Core™ (i9/i7) 支持 DDR4 最高达 2933；Core™ (i5/i3)，Pentium® 和 Celeron® 支持 DDR4 最高达 2666。</li> <li>• 支持 ECC UDIMM 内存模块（非 ECC 模式操作）</li> <li>• 支持系统内存最大容量：64GB</li> <li>• 支持 Intel® Extreme Memory Profile (XMP) 2.0</li> <li>• DIMM 插槽中 15μ 金触点</li> </ul> |
| 扩充槽 | <ul style="list-style-type: none"> <li>• 1 x PCI Express 3.0 x16 槽</li> <li>* 支持 NVMe SSD 用作启动盘</li> <li>• 2 x PCI Express 3.0 x1 槽</li> <li>• 1 x PCI 槽</li> </ul>   |
| 图形  | <ul style="list-style-type: none"> <li>• 只有 GPU 集成的处理器才支持 Intel® UHD Graphics 内置视效和 VGA 输出。</li> <li>• 硬件加速编解码器：AVC/H.264、HEVC/H.265 8-bit、HEVC/H.265 10-bit、VP8、VP9 8-bit、VP9 10-bit、MPEG2、MJPEG、VC-1</li> <li>* VP9 10 位和 VC-1 仅用于解码。</li> <li>* Windows 操作系统不支持 VP8 和 VP9 编码。</li> <li>• 显卡、媒体和计算：Microsoft DirectX 12、OpenGL 4.5、Intel® Built In Visuals、Intel® 高速视频同步、混合 / 可切换显卡、OpenCL 2.1</li> </ul>   |

- 显示和内容安全：Rec. 2020（广色域）、Microsoft PlayReady 3.0、Intel® SGX 内容保护、UHD/HDR 蓝光光盘
- 3 个图形输出选项：D-Sub、DVI-D 和 HDMI
- \* 同时最多支持两个 2 显示器
- 支持 HDMI 1.4，30Hz 时最大分辨率达 4K x 2K (4096x2160)
- 支持 DVI-D，60Hz 时最大分辨率达 1920x1200
- 支持 D-Sub，60Hz 时最大分辨率达 1920x1200
- 通过 HDMI 1.4 端口（需要兼容的 HDMI 显示器）支持 Auto Lip Sync、Deep Color (12bpc)、xvYCC 和 HBR（高位速率音频）
- 通过 DVI-D 和 HDMI 1.4 端口支持 HDCP 2.3
- 通过 HDMI 1.4 端口支持 4K 超高清 (UHD) 播放

#### 音频

- 7.1 CH 高清音频（Realtek ALC887 音频编解码器）
- 支持电涌保护

#### LAN

- PCIE x1 Gigabit LAN 10/100/1000 Mb/s
- Realtek RTL8111GN
- 支持 Wake-On-LAN（网上唤醒）
- 支持雷电 /ESD 保护
- 支持高能效以太网 802.3az
- 支持 PXE

#### 后面板 I/O

- 1 x PS/2 鼠标端口
- 1 x PS/2 键盘端口
- 1 x 串行端口：COM1
- 1 x D-Sub 端口
- 1 x DVI-D 端口
- 1 x HDMI 端口
- 4 x USB 2.0 端口（支持 ESD 保护）(H410M-HDVP)
- 2 x USB 2.0 端口（支持 ESD 保护）(H410M-HDVP2)
- 2 x USB 3.2 Gen1 端口（支持 ESD 保护）
- 1 x RJ-45 LAN 端口，带 LED（ACT/LINK LED 和 SPEED LED）
- 高清音频插孔：线路输入 / 前扬声器 / 麦克风

## 存储

- 4 x SATA3 6.0 Gb/s 接口，支持 NCQ、AHCI 和热插拔 \*
- \* 如果 M2\_1 被 SATA 型 M.2 设备占用，SATA3\_3 将被禁用。
- 1 x M.2 接口 (M2\_1)，支持 2230/2242/2260/2280 M.2 SATA3 6.0 Gb/s M Key 类型模块和 M.2 PCI Express 模块（最高 Gen3 x2 (16 Gb/s)）\*\*
- \*\* 支持 NVMe SSD 用作启动盘
- \*\* 支持华擎 U.2 套件

## 接口

- 1 x 打印端口接脚
- 1 x COM 端口接脚
- 1 x SPI TPM 接脚
- 1 x 机箱侵入和扬声器接脚
- 1 x CPU 风扇接口（4 针）
- \* CPU 风扇接口支持最高 1A (12W) 功率的 CPU 风扇。
- 1 x 机箱风扇接口（4 针）
- \* 机箱风扇接口支持功率最大为 1A (12W) 的机箱风扇。
- 1 x 机箱 / 水泵风扇接口（4 针）（智能风扇速度控制）
- \* 机箱 / 水泵风扇支持最高 2A (24W) 功率的水冷风扇。
- \* CHA\_FAN1/WP 可以自动检测 3 针脚或 4 针脚风扇是否在使用。
- 1 x 24 针 ATX 电源接口
- 1 x 8 针 12V 电源接口
- 1 x 前面板音频接口
- 1 x USB 2.0 接脚（支持 2 个 USB 2.0 端口，支持 ESD 保护）  
(H410M-HDVP)
- 2 x USB 2.0 接脚（支持 4 个 USB 2.0 端口，支持 ESD 保护）  
(H410M-HDVP2)
- 1 x USB 3.2 Gen1 接脚（支持 2 个 USB 3.2 Gen1 端口，支持 ESD 保护）

## 操作系统

- Microsoft® Windows® 10 64-bit

## 电子信息产品污染控制标示

依据中国发布的「电子信息产品污染控制管理办法」及 SJ/T 11364-2006「电子信息产品污染控制标示要求」，电子信息产品应进行标示，藉以向消费者揭露产品中含有的有毒有害物质或元素不致发生外泄或突变从而对环境造成污染或对人身、财产造成严重损害的期限。依上述规定，您可于本产品之印刷电路板上看见图一之标示。图一中之数字为产品之环保使用期限。由此可知此主板之环保使用期限为 10 年。



图一

## 有毒有害物质或元素的名称及含量说明

若您欲了解此产品的有毒有害物质或元素的名称及含量说明，请参照以下表格及说明。

| 部件名称       | 有害物质或元素 |        |        |              |            |              |
|------------|---------|--------|--------|--------------|------------|--------------|
|            | 铅 (Pb)  | 镉 (Cd) | 汞 (Hg) | 六价铬 (Cr(VI)) | 多溴联苯 (PBB) | 多溴二苯醚 (PBDE) |
| 印刷电路板及电子组件 | X       | O      | O      | O            | O          | O            |
| 外部信号连接头及线材 | X       | O      | O      | O            | O          | O            |

O: 表示该有毒有害物质在该部件所有均质材料中的含量均在 SJ/T 11363-2006 标准规定的限量要求以下。

X: 表示该有毒有害物质至少在该部件的某一均质材料中的含量超出 SJ/T 11363-2006 标准规定的限量要求，然该部件仍符合欧盟指令 2002/95/EC 的规范。

备注: 此产品所标示之环保使用年限，系指在一般正常使用状况下。

## 規格

### 平台

- Micro ATX 尺寸
- 固態電容設計

### CPU

- 支援第 10 代 Intel® Core™ 處理器 (Socket 1200)
- Digi Power design
- 7 電源相位設計
- 支援 Intel® Turbo Boost Max 技術 3.0

### 晶片組

- Intel® H410

### 記憶體

- 雙通道 DDR4 記憶體技術
- 2 x DDR4 DIMM 插槽
- 支援 DDR4 2933/2800/2666/2400/2133 非 ECC 無緩衝記憶體
- \* 如需更多資訊，請參閱華擎網站上的記憶體支援表。  
(<http://www.asrock.com/>)
- \* Core™ (i9/i7) 支援最高 2933 DDR4；Core™ (i5/i3)；Pentium® 和 Celeron® 支援最高 2666 DDR4。
- 支援 ECC UDIMM 記憶體模組（於非 ECC 模式下運作）
- 最大系統記憶體容量：64GB
- 支援 Intel® Extreme Memory Profile (XMP) 2.0
- 15μ 特厚鍍金插槽

### 擴充插槽

- 1 x PCI Express 3.0 x16 插槽
- \* 支援 NVMe SSD 作為開機磁碟
- 2 x PCI Express 3.0 x1 插槽
- 1 x PCI 插槽

### 顯示卡

- 僅限整合 GPU 的處理器才可支援 Intel® UHD Graphics Built-in Visuals 及 VGA 輸出。
- 硬體加速編解碼器：AVC/H.264、HEVC/H.265 8 位元、HEVC/H.265 10 位元、VP8、VP9 8 位元、VP9 10 位元、MPEG2、MJPEG、VC-1
- \* VP9 10bit 和 VC-1 僅用於解碼。
- \* Windows 作業系統不支援 VP8 和 VP9 編碼。
- 顯示卡、媒體和運算：Microsoft DirectX 12、OpenGL 4.5、Intel® Built In Visuals、Intel® Quick Sync Video、混合式／可切換顯示卡、OpenCL 2.1



- 顯示和內容安全性：Rec. 2020（廣色域）、Microsoft PlayReady 3.0、Intel® SGX 內容保護、UHD/HDR 藍光光碟
- 三個圖形輸出選項：D-Sub、DVI-D 及 HDMI
- \* 最高同時支援 2 台顯示器
  - 最高支援 4K x 2K (4096x2160) @ 30Hz 解析度的 HDMI 1.4
  - 最高支援 1920x1200 @ 60Hz 解析度的 DVI-D
  - 最高支援 1920x1200 @ 60Hz 解析度的 D-Sub
  - 支援使用 HDMI 1.4 連接埠（需相容於 HDMI 顯示器）的 Auto Lip Sync、Deep Color (12bpc)、xvYCC 及 HBR（高位元率音訊）
  - 支援含 DVI-D 及 HDMI 1.4 連接埠的 HDCP 2.3
  - 支援使用 HDMI 1.4 連接埠進行 4K Ultra HD (UHD) 播放

音訊

- 7.1 CH HD 音訊（Realtek ALC887 音訊轉碼器）
- 支援突波保護

LAN

- PCIE x1 Gigabit LAN 10/100/1000 Mb/s
- Realtek RTL8111GN
- 支援網路喚醒
- 支援雷擊／靜電保護
- 支援 802.3az EEE 節能乙太網路
- 支援 PXE

後面板 I/O

- 1 x PS/2 滑鼠連接埠
- 1 x PS/2 鍵盤連接埠
- 1 x 序列連接埠：COM1
- 1 x D-Sub 連接埠
- 1 x DVI-D 連接埠
- 1 x HDMI 連接埠
- 4 x USB 2.0 連接埠（支援靜電保護）(H410M-HDVP)
- 2 x USB 2.0 連接埠（支援靜電保護）(H410M-HDVP2)
- 2 x USB 3.2 Gen1 連接埠（支援靜電保護）
- 1 x RJ-45 LAN 連接埠，含 LED（ACT/LINK LED 及 SPEED LED）
- HD 音訊插孔：線路輸入／前置喇叭／麥克風

## 儲存裝置

- 4 x SATA3 6.0 Gb/s 接頭，支援 NCQ、AHCI 及「熱插拔」\*
- \* 若 M2\_1 為 SATA 類型的 M.2 裝置佔用，將會停用 SATA3\_3。
- 1 x M.2 插座 (M2\_1)，支援 2230/2242/2260/2280 M.2 SATA3 6.0 Gb/s 模組與 M.2 PCI Express 模組（最高可達 Gen3 x2 (16 Gb/s)）類型\*\*
- \*\* 支援 NVMe SSD 作為開機磁碟
- \*\* 支持華擎 U.2 套件

## 接頭

- 1 x 列印連接埠排針
- 1 x COM 連接埠排針
- 1 x SPI TPM 排針
- 1 x 機殼防護及喇叭排針
- 1 x CPU 風扇接頭 (4-pin)
- \* CPU 風扇接頭支援最高 1A (12W) 風扇功率的 CPU 風扇。
- 1 x 機殼風扇接頭 (4-pin)
- \* 機殼風扇接頭支援最高 1A (12W) 風扇功率的機殼風扇。
- 1 x 機殼／水冷幫浦風扇接頭 (4-pin) (智慧型風扇速度控制)
- \* 機殼／水冷幫浦風扇接頭支援最高 2A (24W) 風扇功率的水冷風扇。
- \* 如果 3-pin 或 4-pin 風扇使用中，可自動偵測 CHA\_FAN1/WP。
- 1 x 24 pin ATX 電源接頭
- 1 x 8 pin 12V 電源接頭
- 1 x 前面板音訊接頭
- 1 x USB 2.0 排針 (支援 2 個 USB 2.0 連接埠) (支援靜電保護) (H410M-HDVP)
- 2 x USB 2.0 排針 (支援 4 個 USB 2.0 連接埠) (支援靜電保護) (H410M-HDVP2)
- 1 x USB 3.2 Gen1 排針 (支援 2 個 USB 3.2 Gen1 連接埠) (支援靜電保護)

## 作業系統

- Microsoft® Windows® 10 64-bit

## Spesifikasi

### Platform

- Bentuk dan Ukuran Micro ATX
- Desain Kapasitor Solid

### CPU

- Mendukung Prosesor Generasi ke-10 Intel® Core™ (Soket 1200)
- Desain Digi Power
- Desain 7 Fase Daya
- Mendukung Teknologi Intel® Turbo Boost Max 3.0

### Chipset

- Intel® H410

### Memori

- Teknologi Memori DDR4 Dua Saluran
- 2 x Slot DIMM DDR4
- Mendukung DDR4 2933/2800/2666/2400/2133 non-ECC, memori tanpa buffer
- \* Lihat Daftar Dukungan Memori pada situs web ASRock untuk informasi selengkapnya. (<http://www.asrock.com/>)
- \* Core™ (i9/i7) mendukung DDR4 hingga 2933; Core™ (i5/i3), Pentium® dan Celeron® mendukung DDR4 hingga 2666.
- Mendukung modul memori ECC UDIMM (berjalan dalam mode non-ECC)
- Kapasitas maksimum memori sistem: 64GB
- Mendukung Intel® Extreme Memory Profile (XMP) 2.0
- 15µ Bidang Kontak Berwarna Emas di Slot DIMM

### Slot Ekspansi

- 1 x Slot PCI Express 3.0 x16
- \* Mendukung SSD NVMe sebagai disk boot
- 2 x Slot PCI Express 3.0 x1
- 1 x Slot PCI

### Grafis

- Intel® UHD Graphics Built-in Visuals dan output VGA hanya didukung dengan prosesor yang terintegrasi GPU.
- Codec Yang Dipercepat Hardware: AVC/H.264, HEVC/H.265 8-bit, HEVC/H.265 10-bit, VP8, VP9 8-bit, VP9 10-bit, MPEG2, MJPEG, VC-1
- \* VP9 10bit dan VC-1 hanya untuk mendekode.
- \* Enkode VP8 dan VP9 tidak didukung oleh Windows OS.
- Grafik, Media & Hitung: Microsoft DirectX 12, OpenGL 4.5, Visual Internal Intel®, Video Sinkronisasi Ceoat Intel®, Grafik Hybrid / Yang Bisa Dialihkan, OpenCL 2.1

- Tampilan & Keamanan Konten: Rec. 2020 (Nuansa Banyak Warna), Microsoft PlayReady 3.0, Perlindungan Konten Intel® SGX, UHD/HDR Blu-ray Disc
- Tiga pilihan output grafis: D-Sub, DVI-D, dan HDMI
- \* Mendukung hingga 2 tampilan secara bersamaan
- Mendukung HDMI 1.4 dengan resolusi maksimum hingga 4K x 2K (4096x2160) @ 30Hz
- Mendukung DVI-D dengan resolusi maksimum hingga 1920x1200 @ 60Hz
- Mendukung D-Sub dengan resolusi maksimum hingga 1920x1200 @ 60Hz
- Mendukung Auto Lip Sync, Kedalaman Warna (12bpc), xvYCC, dan HBR (Audio High Bit Rate) dengan Port HDMI 1.4 (memerlukan monitor yang kompatibel dengan HDMI)
- Mendukung HDCP 2.3 dengan port DVI-D dan HDMI 1.4
- Mendukung pemutaran Ultra HD 4K (UHD) dengan Port HDMI 1.4

#### Audio

- Audio HD 7.1 CH (Realtek ALC887 Audio Codec)
- Mendukung Perlindungan dari Lonjakan Arus

#### LAN

- 1 x PCIE Gigabit LAN 10/100/1000 Mb/s
- Realtek RTL8111GN
- Mendukung Wake-On-LAN
- Mendukung Perlindungan dari Petir/ESD
- Mendukung Ethernet 802.3az Hemat Energi
- Mendukung PXE

#### I/O Panel Belakang

- 1 x Port Mouse PS/2
- 1 x Port Keyboard PS/2
- 1 x Port Seri: COM1
- 1 x Port D-Sub
- 1 x Port DVI-D
- 1 x Port HDMI
- 4 x Port USB 2.0 (Mendukung Perlindungan ESD) (**H410M-HDVP**)
- 2 x Port USB 2.0 (Mendukung Perlindungan ESD) (**H410M-HDVP2**)
- 2 x Port USB 3.2 Gen1 (Mendukung Perlindungan dari ESD)
- 1 x Port LAN RJ-45 dengan LED (LED ACT/LINK dan LED SPEED)
- Soket Audio HD: Saluran Masuk/Speaker Depan/Mikrofon

## Penyimpanan

- 4 x Konektor SATA3 6,0 Gb/s, mendukung NCQ, AHCI, dan Hot Plug\*
- \* Jika M2\_1 digunakan oleh perangkat SATA tipe M.2, maka SATA3\_3 akan dinonaktifkan.
- 1 x Soket M.2 (M2\_1), mendukung modul M Key tipe 2230/2242/2260/2280 M.2 SATA3 6,0 Gb/s dan modul M.2 PCI Express hingga Gen3 x2 (16 Gb/s)\*\*
- \*\* Mendukung SSD NVMe sebagai disk boot
- \*\* Mendukung Kit ASRock U.2

## Konektor

- 1 x Header Port Printer
- 1 x Header Port COM
- 1 x Header SPI TPM
- 1 x Intrusi Chassis dan Header Speaker
- 1 x Konektor Kipas CPU (4-pin)
- \* Konektor Kipas CPU mendukung kipas CPU dengan daya kipas maksimum 1A (12W).
- 1 x Konektor Kipas Chassis (4-pin)
- \* Konektor Kipas Sasis mendukung kipas sasis dengan daya kipas maksimum 1A (12W).
- 1 x Konektor Kipas Chassis/Pompa Air (4-pin) (Kontrol Kecepatan Kipas Pintar)
- \* Chassis/Kipas Pompa Air mendukung kipas berpendingin air dengan daya kipas maksimum 2A (24W).
- \* CHA\_FAN1/WP dapat mendeteksi otomatis jika kipas 3-pin atau 4-pin sedang digunakan.
- 1 x Konektor Daya ATX 24 pin
- 1 x Konektor Daya 8 pin 12V
- 1 x Konektor Audio Panel Depan
- 1 x Header USB 2.0 (Mendukung 2 port USB 2.0) (Mendukung Perlindungan dari ESD) (**H410M-HDVP**)
- 2 x Header USB 2.0 (Mendukung 4 port USB 2.0) (Mendukung Perlindungan dari ESD) (**H410M-HDVP2**)
- 1 x Header USB 3.2 Gen1 (Mendukung 2 port USB 3.2 Gen1) (Mendukung Perlindungan dari ESD)

## OS

- Microsoft® Windows® 10 64-bit

## Contact Information

If you need to contact ASRock or want to know more about ASRock, you're welcome to visit ASRock's website at <http://www.asrock.com>; or you may contact your dealer for further information. For technical questions, please submit a support request form at <http://www.asrock.com/support/tsd.asp>

### **ASRock Incorporation**

2F., No.37, Sec. 2, Jhongyang S. Rd., Beitou District,  
Taipei City 112, Taiwan (R.O.C.)

### **ASRock EUROPE B.V.**

Bijsterhuizen 11-11

6546 AR Nijmegen

The Netherlands

Phone: +31-24-345-44-33

Fax: +31-24-345-44-38

### **ASRock America, Inc.**

13848 Magnolia Ave, Chino, CA91710

U.S.A.

Phone: +1-909-590-8308

Fax: +1-909-590-1026

# DECLARATION OF CONFORMITY

Per FCC Part 2 Section 2.1077(a)



**Responsible Party Name:** ASRock Incorporation

**Address:** 13848 Magnolia Ave, Chino, CA91710

**Phone/Fax No:** +1-909-590-8308/+1-909-590-1026

hereby declares that the product

**Product Name :** Motherboard

**Model Number :** H410M-HDVP / H410M-HDVP2

Conforms to the following specifications:

FCC Part 15, Subpart B, Unintentional Radiators

## Supplementary Information:

This device complies with part 15 of the FCC Rules. Operation is subject to the following two conditions: (1) This device may not cause harmful interference, and (2) this device must accept any interference received, including interference that may cause undesired operation.

Representative Person's Name: James

Signature:

A handwritten signature in black ink, appearing to read 'James', written over a horizontal line.

Date : May 12, 2017

# EU Declaration of Conformity



For the following equipment:

**Motherboard**

(Product Name)

**H410M-HDVP / H410M-HDVP2 / ASRock**

(Model Designation / Trade Name)

**ASRock Incorporation**

(Manufacturer Name)

**2F., No.37, Sec. 2, Jhongyang S. Rd., Beitou District, Taipei City 112, Taiwan (R.O.C.)**

(Manufacturer Address)

**EMC — Directive 2014/30/EU (from April 20th, 2016)**

EN 55022:2010/AC:2011 Class B

EN 55024:2010/A1:2015

EN 55032:2012+AC:2013 Class B

EN 61000-3-3:2013

EN 61000-3-2:2014

**LVD — Directive 2014/35/EU (from April 20th, 2016)**

EN 60950-1 : 2011+ A2: 2013

EN 60950-1 : 2006/A12: 2011

**RoHS — Directive 2011/65/EU**

**CE marking**

(EU conformity marking)



**ASRock EUROPE B.V.**

(Company Name)

**Bijsterhuizen 1111 6546 AR Nijmegen The Netherlands**

(Company Address)

Person responsible for making this declaration:

(Name, Surname)

**A.V.P**

(Position / Title)

**May 29, 2020**

(Date)

P/N: 15G062222000AK V1.0