

Version 1.0

Published February 2018

Copyright©2018 ASRock INC. All rights reserved.



Copyright Notice:

No part of this documentation may be reproduced, transcribed, transmitted, or translated in any language, in any form or by any means, except duplication of documentation by the purchaser for backup purpose, without written consent of ASRock Inc.

Products and corporate names appearing in this documentation may or may not be registered trademarks or copyrights of their respective companies, and are used only for identification or explanation and to the owners' benefit, without intent to infringe.

Disclaimer:

Specifications and information contained in this documentation are furnished for informational use only and subject to change without notice, and should not be construed as a commitment by ASRock. ASRock assumes no responsibility for any errors or omissions that may appear in this documentation.

With respect to the contents of this documentation, ASRock does not provide warranty of any kind, either expressed or implied, including but not limited to the implied warranties or conditions of merchantability or fitness for a particular purpose.

In no event shall ASRock, its directors, officers, employees, or agents be liable for any indirect, special, incidental, or consequential damages (including damages for loss of profits, loss of business, loss of data, interruption of business and the like), even if ASRock has been advised of the possibility of such damages arising from any defect or error in the documentation or product.



This device complies with Part 15 of the FCC Rules. Operation is subject to the following two conditions:

- (1) this device may not cause harmful interference, and
- (2) this device must accept any interference received, including interference that may cause undesired operation.

CALIFORNIA, USA ONLY

The Lithium battery adopted on this motherboard contains Perchlorate, a toxic substance controlled in Perchlorate Best Management Practices (BMP) regulations passed by the California Legislature. When you discard the Lithium battery in California, USA, please follow the related regulations in advance.

“Perchlorate Material-special handling may apply, see www.dtsc.ca.gov/hazardouswaste/perchlorate”

ASRock Website: <http://www.asrock.com>

AUSTRALIA ONLY

Our goods come with guarantees that cannot be excluded under the Australian Consumer Law. You are entitled to a replacement or refund for a major failure and compensation for any other reasonably foreseeable loss or damage caused by our goods. You are also entitled to have the goods repaired or replaced if the goods fail to be of acceptable quality and the failure does not amount to a major failure. If you require assistance please call ASRock Tel : +886-2-28965588 ext.123 (Standard International call charges apply)

Motherboard Layout

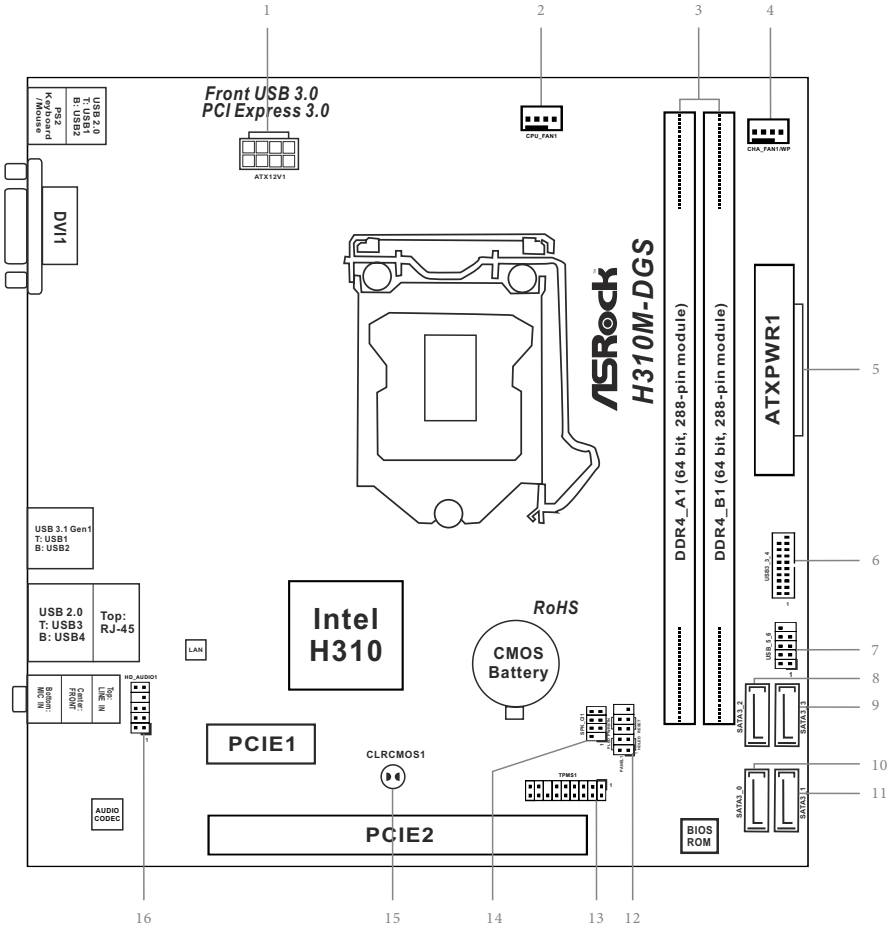

No.	Description
1	ATX 12V Power Connector (ATX12V1)
2	CPU Fan Connector (CPU_FAN1)
3	2 x 288-pin DDR4 DIMM Slots (DDR4_A1, DDR4_B1)
4	Chassis/Water Pump Fan Connector (CHA_FAN1/WP)
5	ATX Power Connector (ATXPWR1)
6	USB 3.1 Gen1 Header (USB3_3_4)
7	USB 2.0 Header (USB_5_6)
8	SATA3 Connector (SATA3_2)
9	SATA3 Connector (SATA3_3)
10	SATA3 Connector (SATA3_0)
11	SATA3 Connector (SATA3_1)
12	System Panel Header (PANEL1)
13	TPM Header (TPMS1)
14	Chassis Intrusion and Speaker Header (SPK_CI1)
15	Clear CMOS Pad (CLRMOS1)
16	Front Panel Audio Header (HD_AUDIO1)

I/O Panel

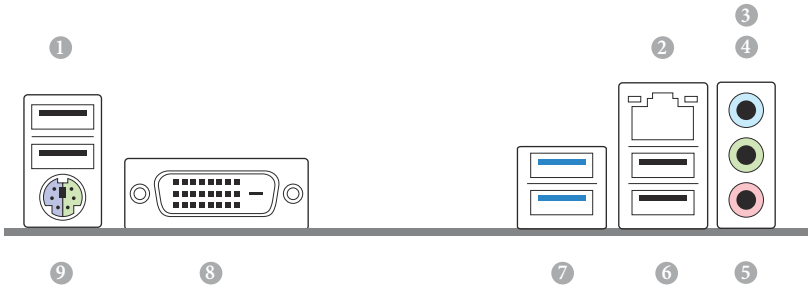

No.	Description	No.	Description
1	USB 2.0 Ports (USB12)	6	USB 2.0 Ports (USB_34)
2	LAN RJ-45 Port*	7	USB 3.1 Gen1 Ports (USB3_12)
3	Line In (Light Blue)**	8	DVI-D Port
4	Front Speaker (Lime)**	9	PS/2 Keyboard/Mouse Port
5	Microphone (Pink)**		

* There are two LEDs on each LAN port. Please refer to the table below for the LAN port LED indications.

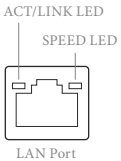

Activity / Link LED		Speed LED	
Status	Description	Status	Description
Off	No Link	Off	10Mbps connection
Blinking	Data Activity	Orange	100Mbps connection
On	Link	Green	1Gbps connection

** To configure 7.1 CH HD Audio, it is required to use an HD front panel audio module and enable the multi-channel audio feature through the audio driver.

Please set Speaker Configuration to “7.1 Speaker” in the Realtek HD Audio Manager.

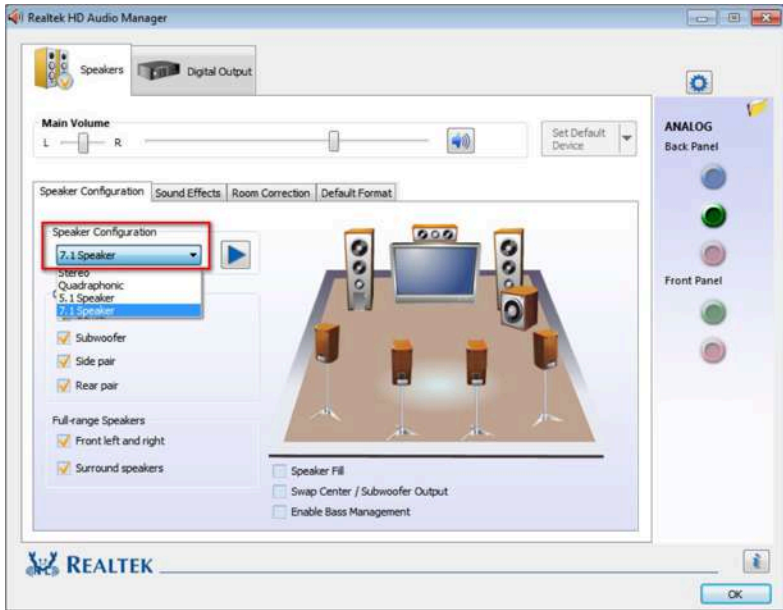

Function of the Audio Ports in 7.1-channel Configuration:

Port	Function
Light Blue (Rear panel)	Rear Speaker Out
Lime (Rear panel)	Front Speaker Out
Pink (Rear panel)	Central /Subwoofer Speaker Out
Lime (Front panel)	Side Speaker Out

Chapter 1 Introduction

Thank you for purchasing ASRock H310M-DGS motherboard, a reliable motherboard produced under ASRock's consistently stringent quality control. It delivers excellent performance with robust design conforming to ASRock's commitment to quality and endurance.



Because the motherboard specifications and the BIOS software might be updated, the content of this documentation will be subject to change without notice. In case any modifications of this documentation occur, the updated version will be available on ASRock's website without further notice. If you require technical support related to this motherboard, please visit our website for specific information about the model you are using. You may find the latest VGA cards and CPU support list on ASRock's website as well. ASRock website <http://www.asrock.com>.

1.1 Package Contents

- ASRock H310M-DGS Motherboard (Micro ATX Form Factor)
- ASRock H310M-DGS Quick Installation Guide
- ASRock H310M-DGS Support CD
- 1 x I/O Panel Shield
- 2 x Serial ATA (SATA) Data Cables (Optional)

1.2 Specifications

- Platform**
- Micro ATX Form Factor
 - Solid Capacitor design

- CPU**
- Supports 8th Generation Intel® Core™ Processors (Socket 1151)
 - 5 Power Phase design
 - Supports Intel® Turbo Boost 2.0 Technology

- Chipset**
- Intel® H310

- Memory**
- Dual Channel DDR4 Memory Technology
 - 2 x DDR4 DIMM Slots
 - Supports DDR4 2666/2400/2133 non-ECC, un-buffered memory
 - Max. capacity of system memory: 32GB
 - Supports Intel® Extreme Memory Profile (XMP) 2.0
 - 15µ Gold Contact in DIMM Slots

- Expansion Slot**
- 1 x PCI Express 3.0 x16 Slot (PCIe2: x16 mode)*
- * Supports NVMe SSD as boot disks
- 1 x PCI Express 2.0 x1 Slot

- Graphics**
- Intel® UHD Graphics Built-in Visuals and the VGA outputs can be supported only with processors which are GPU integrated.
 - Supports Intel® UHD Graphics Built-in Visuals : Intel® Quick Sync Video with AVC, MVC (S3D) and MPEG-2 Full HW Encode1, Intel® InTru™ 3D, Intel® Clear Video HD Technology, Intel® Insider™, Intel® UHD Graphics
 - DirectX 12
 - HWAEncode/Decode: AVC/H.264, HEVC/H.265 8-bit, HEVC/H.265 10-bit, VP8, VP9 8-bit, VP9 10-bit (Decode only), MPEG2, MJPEG, VC-1 (Decode only)
 - Supports DVI-D with max. resolution up to 1920x1200 @ 60Hz

- Supports HDCP with DVI-D Port

Audio

- 7.1 CH HD Audio (Realtek ALC887 Audio Codec)
- * To configure 7.1 CH HD Audio, it is required to use an HD front panel audio module and enable the multi-channel audio feature through the audio driver.
 - Supports Surge Protection
 - ELNA Audio Caps

LAN

- PCIE x1 Gigabit LAN 10/100/1000 Mb/s
- 1 x Realtek RTL8111H
- Supports Wake-On-LAN
- Supports Lightning/ESD Protection
- Supports Energy Efficient Ethernet 802.3az
- Supports PXE

Rear Panel I/O

- 1 x PS/2 Mouse/Keyboard Port
- 1 x DVI-D Port
- 4 x USB 2.0 Ports (Supports ESD Protection)
- 2 x USB 3.1 Gen1 Ports (Supports ESD Protection)
- 1 x RJ-45 LAN Port with LED (ACT/LINK LED and SPEED LED)
- HD Audio Jacks: Line in / Front Speaker / Microphone

Storage

- 4 x SATA3 6.0 Gb/s Connectors, support NCQ, AHCI and Hot Plug

Connector

- 1 x TPM Header
- 1 x Chassis Intrusion and Speaker Header
- 1 x CPU Fan Connector (4-pin)
- * The CPU Fan Connector supports the CPU fan of maximum 1A (12W) fan power.
 - 1 x Chassis/Water Pump Fan Connector (4-pin) (Smart Fan Speed Control)
 - * The Chassis/Water Pump Fan supports the water cooler fan of maximum 2A (24W) fan power.
 - * CHA_FAN1/WP can auto detect if 3-pin or 4-pin fan is in use.

- 1 x 24 pin ATX Power Connector
- 1 x 8 pin 12V Power Connector
- 1 x Front Panel Audio Connector
- 1 x USB 2.0 Header (Supports 2 USB 2.0 ports) (Supports ESD Protection)
- 1 x USB 3.1 Gen1 Header (Supports 2 USB 3.1 Gen1 ports) (Supports ESD Protection)

**BIOS
Feature**

- AMI UEFI Legal BIOS with multilingual GUI support
- ACPI 6.0 Compliant wake up events
- SMBIOS 2.7 Support
- DRAM, PCH 1.05V Voltage Multi-adjustment

**Hardware
Monitor**

- Temperature Sensing: CPU, Chassis/Water Pump Fans
- Fan Tachometer: CPU, Chassis/Water Pump Fans
- Quiet Fan (Auto adjust chassis fan speed by CPU temperature): CPU, Chassis/Water Pump Fans
- Fan Multi-Speed Control: CPU, Chassis/Water Pump Fans
- CASE OPEN detection
- Voltage monitoring: +12V, +5V, +3.3V, CPU Vcore

OS

- Microsoft® Windows® 10 64-bit

**Certifica-
tions**

- FCC, CE
- ErP/EuP ready (ErP/EuP ready power supply is required)

* For detailed product information, please visit our website: <http://www.asrock.com>



Please realize that there is a certain risk involved with overclocking, including adjusting the setting in the BIOS, applying Untied Overclocking Technology, or using third-party overclocking tools. Overclocking may affect your system's stability, or even cause damage to the components and devices of your system. It should be done at your own risk and expense. We are not responsible for possible damage caused by overclocking.

Chapter 2 Installation

This is a Micro ATX form factor motherboard. Before you install the motherboard, study the configuration of your chassis to ensure that the motherboard fits into it.

Pre-installation Precautions

Take note of the following precautions before you install motherboard components or change any motherboard settings.

- Make sure to unplug the power cord before installing or removing the motherboard components. Failure to do so may cause physical injuries and damages to motherboard components.
- In order to avoid damage from static electricity to the motherboard's components, NEVER place your motherboard directly on a carpet. Also remember to use a grounded wrist strap or touch a safety grounded object before you handle the components.
- Hold components by the edges and do not touch the ICs.
- Whenever you uninstall any components, place them on a grounded anti-static pad or in the bag that comes with the components.
- When placing screws to secure the motherboard to the chassis, please do not over-tighten the screws! Doing so may damage the motherboard.

2.1 Installing the CPU

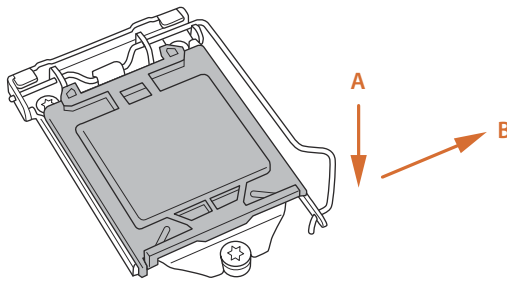
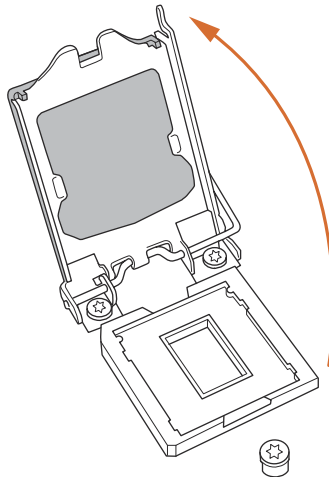

1. Before you insert the 1151-Pin CPU into the socket, please check if the **PnP cap** is on the socket, if the CPU surface is unclean, or if there are any **bent pins** in the socket. Do not force to insert the CPU into the socket if above situation is found. Otherwise, the CPU will be seriously damaged.
2. Unplug all power cables before installing the CPU.

1**2**

3

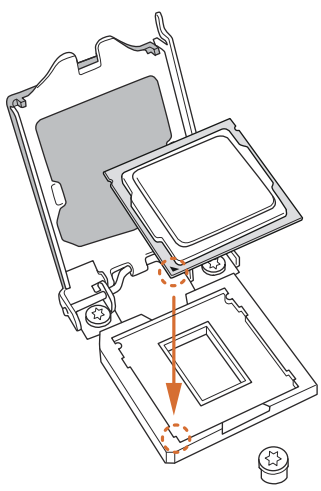

4

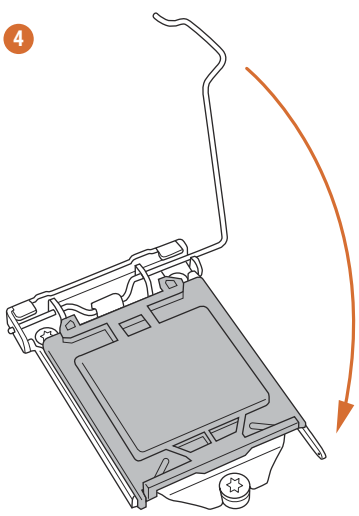

5

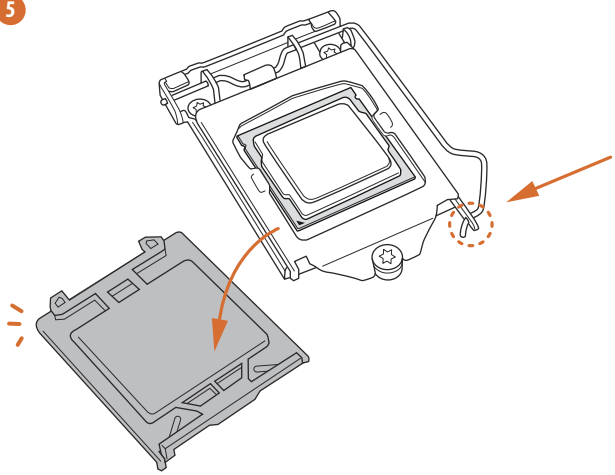



Please save and replace the cover if the processor is removed. The cover must be placed if you wish to return the motherboard for after service.

2.2 Installing the CPU Fan and Heatsink

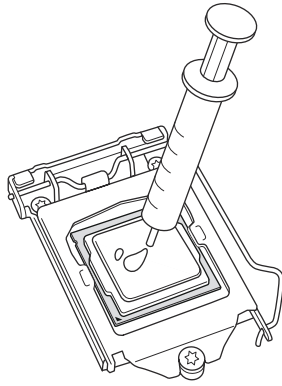

1

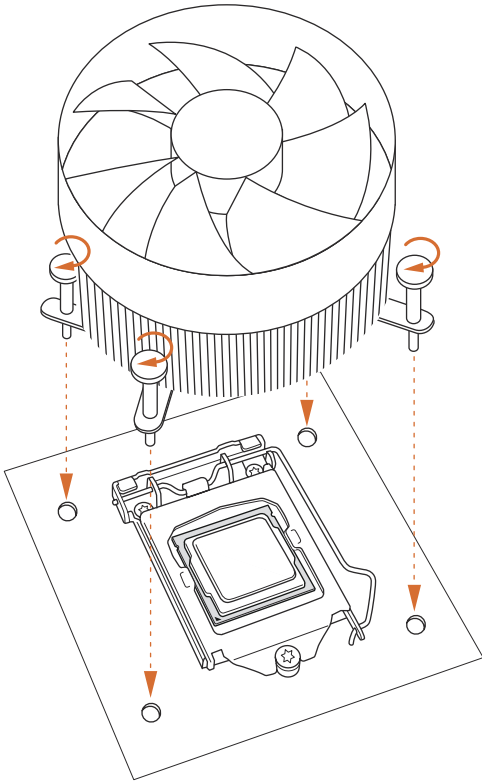

2

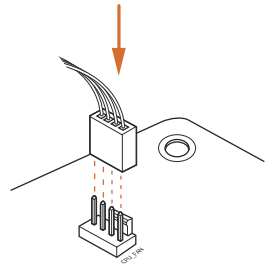

2.3 Installing Memory Modules (DIMM)

This motherboard provides two 288-pin DDR4 (Double Data Rate 4) DIMM slots, and supports Dual Channel Memory Technology.



1. For dual channel configuration, you always need to install identical (the same brand, speed, size and chip-type) DDR4 DIMM pairs.
2. It is unable to activate Dual Channel Memory Technology with only one memory module installed.
3. It is not allowed to install a DDR, DDR2 or DDR3 memory module into a DDR4 slot; otherwise, this motherboard and DIMM may be damaged.



The DIMM only fits in one correct orientation. It will cause permanent damage to the motherboard and the DIMM if you force the DIMM into the slot at incorrect orientation.

1

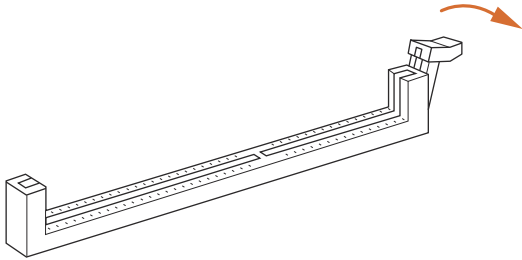

2

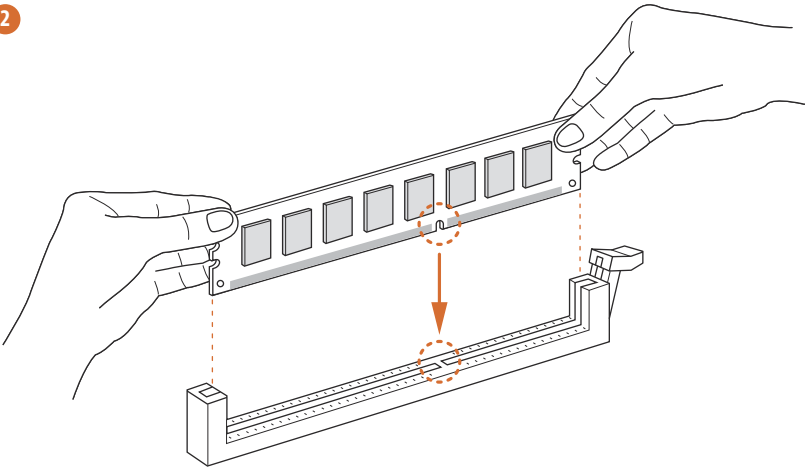

3

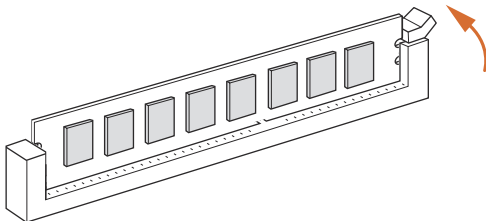

2.4 Expansion Slots (PCI Express Slots)

There are 2 PCI Express slots on the motherboard.



Before installing an expansion card, please make sure that the power supply is switched off or the power cord is unplugged. Please read the documentation of the expansion card and make necessary hardware settings for the card before you start the installation.

PCIe slots:

PCIE1 (PCIe 2.0 x1 slot) is used for PCI Express x1 lane width cards.

PCIE2 (PCIe 3.0 x16 slot) is used for PCI Express x16 lane width graphics cards.

2.5 Onboard Headers and Connectors



Onboard headers and connectors are NOT jumpers. Do NOT place jumper caps over these headers and connectors. Placing jumper caps over the headers and connectors will cause permanent damage to the motherboard.

System Panel Header
(9-pin PANEL1)
(see p.1, No. 12)

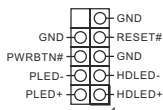

Connect the power button, reset button and system status indicator on the chassis to this header according to the pin assignments below. Note the positive and negative pins before connecting the cables.



PWRBTN (Power Button):

Connect to the power button on the chassis front panel. You may configure the way to turn off your system using the power button.

RESET (Reset Button):

Connect to the reset button on the chassis front panel. Press the reset button to restart the computer if the computer freezes and fails to perform a normal restart.

PLED (System Power LED):

Connect to the power status indicator on the chassis front panel. The LED is on when the system is operating. The LED keeps blinking when the system is in S1/S3 sleep state. The LED is off when the system is in S4 sleep state or powered off (S5).

HDLED (Hard Drive Activity LED):

Connect to the hard drive activity LED on the chassis front panel. The LED is on when the hard drive is reading or writing data.

The front panel design may differ by chassis. A front panel module mainly consists of power button, reset button, power LED, hard drive activity LED, speaker and etc. When connecting your chassis front panel module to this header, make sure the wire assignments and the pin assignments are matched correctly.

Chassis Intrusion and Speaker Header
(7-pin SPK_CI1)
(see p.1, No. 14)

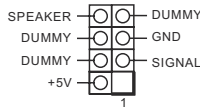

Please connect the chassis intrusion and the chassis speaker to this header.

Serial ATA3 Connectors
(SATA3_0:
see p.1, No. 10)
(SATA3_1:
see p.1, No. 11)
(SATA3_2:
see p.1, No. 8)
(SATA3_3:
see p.1, No. 9)

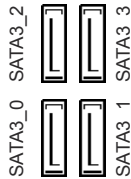

These four SATA3 connectors support SATA data cables for internal storage devices with up to 6.0 Gb/s data transfer rate.

USB 2.0 Header
(9-pin USB_5_6)
(see p.1, No. 7)

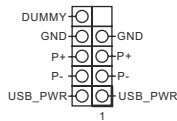

There is one USB 2.0 header on this motherboard. This USB 2.0 header can support two ports.

USB 3.1 Gen1 Header
(19-pin USB3_3_4)
(see p.1, No. 6)

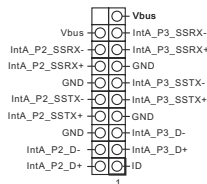

There is one header on this motherboard. This USB 3.1 Gen1 header can support two ports.

Front Panel Audio Header
(9-pin HD_AUDIO1)
(see p.1, No. 16)

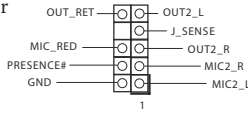

This header is for connecting audio devices to the front audio panel.



1. High Definition Audio supports Jack Sensing, but the panel wire on the chassis must support HDA to function correctly. Please follow the instructions in our manual and chassis manual to install your system.
2. If you use an AC'97 audio panel, please install it to the front panel audio header by the steps below:
 - A. Connect Mic_IN (MIC) to MIC2_L.
 - B. Connect Audio_R (RIN) to OUT2_R and Audio_L (LIN) to OUT2_L.
 - C. Connect Ground (GND) to Ground (GND).
 - D. MIC_RET and OUT_RET are for the HD audio panel only. You don't need to connect them for the AC'97 audio panel.
 - E. To activate the front mic, go to the "FrontMic" Tab in the Realtek Control panel and adjust "Recording Volume".

Chassis/Water Pump Fan Connector
(4-pin CHA_FAN1/WP)
(see p.1, No. 4)

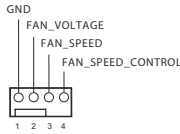

This motherboard provides a 4-Pin water cooling chassis fan connectors. If you plan to connect a 3-Pin chassis water cooler fan, please connect it to Pin 1-3.

CPU Fan Connector
(4-pin CPU_FAN1)
(see p.1, No. 2)

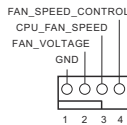

This motherboard provides a 4-Pin CPU fan (Quiet Fan) connector. If you plan to connect a 3-Pin CPU fan, please connect it to Pin 1-3.

ATX Power Connector
(24-pin ATXPWR1)
(see p.1, No. 5)

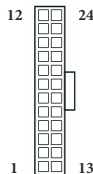

This motherboard provides a 24-pin ATX power connector. To use a 20-pin ATX power supply, please plug it along Pin 1 and Pin 13.

ATX 12V Power Connector
(8-pin ATX12V1)
(see p.1, No. 1)

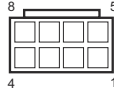

This motherboard provides an 8-pin ATX 12V power connector. To use a 4-pin ATX power supply, please plug it along Pin 1 and Pin 5.

TPM Header
(17-pin TPMS1)
(see p.1, No. 13)

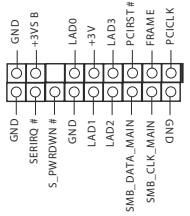

This connector supports Trusted Platform Module (TPM) system, which can securely store keys, digital certificates, passwords, and data. A TPM system also helps enhance network security, protects digital identities, and ensures platform integrity.

Clear CMOS Pad
(CLRMOSE1)
(see p.1, No. 15)



CLRMOSE1 allows you to clear the data in CMOS. To clear CMOS, take out the CMOS battery and short the Clear CMOS Pad.

Technische Daten

- Plattform**
- Micro-ATX-Formfaktor
 - Feststoffkondensator-Design

- Prozessor**
- Unterstützt Intel® Core™-Prozessoren (Sockel 1151) der 8^{ten} Generation
 - 5-Leistungsphasendesign
 - Unterstützt Intel® Turbo Boost 2.0-Technologie

- Chipsatz**
- Intel® H310

- Speicher**
- Dualkanal-DDR4-Speichertechnologie
 - 2 x DDR4-DIMM-Steckplätze
 - Unterstützt ungepufferten DDR4-2666/2400/2133-Non-ECC-Speicher
 - Systemspeicher, max. Kapazität: 32 GB
 - Unterstützt Intel® Extreme Memory Profile (XMP) 2.0
 - 15-µ-Goldkontakt in DIMM-Steckplätze

- Erweiterungssteckplatz**
- 1 x PCI-Express 3.0-x16-Steckplatz (PCIe2:x16-Modus)*
 - * Unterstützt NVMe-SSD als Bootplatte
 - 1 x PCI-Express 2.0-x1-Steckplatz

- Grafikkarte**
- Integrierte Intel® UHD Graphics-Visualisierung und VGA-Ausgänge können nur mit Prozessoren unterstützt werden, die GPU-integriert sind.
 - Unterstützt integrierte Intel® UHD Graphics-Visualisierung: Intel® Quick Sync Video mit AVC, MVC (S3D) und MPEG-2 Full HW Encode1, Intel® InTru™ 3D, Intel® Clear Video HD Technology, Intel® Insider™, Intel® UHD Graphics
 - DirectX 12
 - HWA encodieren/decodieren: AVC/H.264, HEVC/H.265 8 bit, HEVC/H.265 10 bit, VP8, VP9 8 bit, VP9 10 bit (nur Dekodierung), MPEG2, MJPEG, VC-1 (nur Dekodierung)
 - Unterstützt DVI-D mit maximaler Auflösung von 1920 x 1200 bei 60 Hz

- Unterstützt HDCP mit DVI-D-Port

Audio

- 7.1-Kanal-HD-Audio (Realtek ALC887-Audiocodec)
- * Zur Konfiguration von 7.1-Kanal-HD-Audio müssen Sie ein HD-Frontblenden-Audiomodul nutzen und den Mehrkanalton über den Audiotreiber aktivieren.
- Unterstützt Überspannungsschutz
- ELNA-Audiokondensatoren

LAN

- PCIe-x1-Gigabit-LAN 10/100/1000 Mb/s
- 1 x Realtek RTL8111H
- Unterstützt Wake-On-LAN
- Unterstützt Schutz gegen Blitzschlag/elektrostatische Entladung
- Unterstützt energieeffizientes Ethernet 802.3az
- Unterstützt PXE

Rückblende, E/A

- 1 x PS/2-Maus-/Tastaturanschluss
- 1 x DVI-D-Port
- 4 x USB-2.0-Ports (unterstützt Schutz gegen elektrostatische Entladung)
- 2 x USB-3.1-Gen1-Ports (unterstützt Schutz gegen elektrostatische Entladung)
- 1 x RJ-45-LAN-Port mit LED (Aktivität/Verbindung-LED und Geschwindigkeit-LED)
- HD-Audioanschlüsse: Line-in / Vorderer Lautsprecher / Mikrofon

Speicher

- 4 x SATA-III-6,0-Gb/s-Anschlüsse, unterstützt NCQ, AHCI und Hot-Plugging

Anschluss

- 1 x TPM-Stiftleiste
- 1 x Gehäuseeingriff- und Lautsprecher-Stiftleiste
- 1 x CPU-Lüfteranschluss (4-polig)
- * Der CPU-Lüfteranschluss unterstützt einen CPU-Lüfter mit einer maximalen Lüfterleistung von 1 A (12 W).
- 1 x Anschluss Gehäuse/Wasserpumpenlüfter (4-polig) (intelligente Lüftergeschwindigkeitssteuerung)

* Der Gehäuse-/Wasserpumpenlüfter unterstützt einen Wasserkühlerlüfter mit einer maximalen Lüfterleistung von 2A (24 W).

* CHA_FAN1/WP können automatisch erkennen, ob ein 3- oder 4-poliger Lüfter verwendet wird.

- 1 x 24-poliger ATX-Netzanschluss
- 1 x 8-poliger 12-V-Netzanschluss
- 1 x Audioanschluss an Frontblende
- 1 x USB 2.0-Stiflleiste (unterstützt zwei USB 2.0-Ports) (unterstützt Schutz gegen elektrostatische Entladung)
- 1 x USB 3.1 Gen1-Stiflleiste (unterstützt zwei USB 3.1 Gen1-Ports) (unterstützt Schutz gegen elektrostatische Entladung)

BIOS-Funktion

- AMI-UEFI-Legal-BIOS mit Unterstützung mehrsprachiger grafischer Benutzerschnittstellen
- ACPI 6.0-konforme Aufweckereignisse
- SMBIOS 2.7-Unterstützung
- DRAM, PCH 1,05 V / Mehrfachspannungsanpassung

Hardwareüberwachung

- Temperaturerkennung: CPU-, Gehäuse-/Wasserpumpen-Lüfter
- Lüftertachometer: CPU-, Gehäuse-/Wasserpumpen-Lüfter
- Lautloser Lüfter (automatische Anpassung der Gehäuselüftergeschwindigkeit durch CPU-Temperatur): CPU-, Gehäuse-/Wasserpumpen-Lüfter
- Mehrfachgeschwindigkeitssteuerung: CPU-, Gehäuse-/Wasserpumpen-Lüfter
- Gehäuse-offen-Erkennung
- Spannungsüberwachung: +12 V, +5 V, +3,3 V, CPU Vcore

Betriebssystem

- Microsoft® Windows® 10, 64 Bit

Zertifizierungen

- FCC, CE
- ErP/EuP ready (ErP/EuP ready-Netzteil erforderlich)

Spécifications

- Plateforme**
- Facteur de forme Micro ATX
 - Conception à condensateurs solides

- Processeur**
- Prend en charge les processeurs 8^{ème} génération Intel® Core™ (socket 1151)
 - Alimentation à 5 phases
 - Prend en charge la technologie Intel® Turbo Boost 2.0

- Chipset**
- Intel® H310

- Mémoire**
- Technologie mémoire double canal DDR4
 - 2 x fentes DIMM DDR4
 - Prend en charge les mémoires sans tampon non ECC DDR4 2666/2400/2133
 - Capacité max. de la mémoire système : 32GB
 - Prend en charge Intel® Extreme Memory Profile (XMP) 2.0
 - Contacts dorés 15µ sur fentes DIMM

- Fente d'expansion**
- 1 x fente PCI Express 3.0 x 16 (PCIe2 :mode x16)*
 - * Prend en charge les SSD NVMe comme disques de démarrage
 - 1 x fente PCI Express 2.0 x1

- Graphiques**
- La technologie Intel® UHD Graphics Built-in Visuals et les sorties VGA sont uniquement prises en charge par les processeurs intégrant un contrôleur graphique.
 - Prend en charge la technologie Intel® UHD Graphics Built-in Visuals : Intel® Quick Sync Video avec AVC, MVC (S3D) et MPEG-2 Full HW Encode1, Intel® InTru™ 3D, Intel® Clear Video HD Technology, Intel® Insider™, Intel® UHD Graphics
 - DirectX 12
 - Codage/Décodage HWA : AVC/H.264, HEVC/H.265 8 bits, HEVC/H.265 10 bits, VP8, VP9 8 bits, VP9 10 bits (Encodage uniquement), MPEG2, MJPEG, VC-1 (Encodage uniquement)
 - Prend en charge le mode DVI-D avec une résolution maximale de 1920x1200 @ 60Hz

- Prend en charge HDCP via ports DVI-D

Audio

- Audio 7.1 CH HD (Codec audio Realtek ALC887)
- *Pour configurer l'audio 7.1 CH HD, il est nécessaire d'utiliser un module audio HD pour panneau frontal et d'activer la fonction audio multicanal via le pilote audio.
- Prend en charge la protection contre les surtensions
 - Capuchons ELNA Audio

Réseau

- PCIE x1 Gigabit LAN 10/100/1000 Mo/s
- 1 x Realtek RTL8111H
- Prend en charge la fonction Wake-On-LAN
- Prend en charge la protection contre la foudre/les décharges électrostatiques
- Prend en charge la fonction d'économie d'énergie Ethernet 802.3az
- Prend en charge PXE

Connectique du panneau arrière

- 1 x port souris/clavier PS/2
- 1 x port DVI-D
- 4 x ports USB 2.0 (Protection contre les décharges électrostatiques)
- 2 x ports USB 3.1 Gen1 (Protection contre les décharges électrostatiques)
- 1 x port RJ-45 LAN avec LED (LED ACT/LIEN et LED VITESSE)
- Connecteurs jack audio HD : Entrée ligne / haut-parleur avant / microphone

Stockage

- 4 x connecteurs SATA3 6,0 Gb/s, compatibles avec les fonctions NCQ, AHCI et « Hot Plug »

Connecteur

- 1 x embase TPM
 - 1 x prise DEL d'alimentation et emplacement sur châssis
 - 1 x connecteur pour ventilateur de CPU (4 broches)
- * Le connecteur pour ventilateur de CPU prend en charge un ventilateur de CPU d'une puissance maximale de 1 A (12 W).
- 1 x connecteur pour ventilateur de châssis /pompe à eau (4 broches) (contrôle de vitesse de ventilateur intelligent)
- * Le ventilateur de châssis pompe à eau prend en charge un ventilateur de refroidisseur d'eau d'une puissance maximale de 2 (24 W).
- * CHA_FAN1/WP peuvent détecter automatiquement si un ventilateur 3 broches ou 4 broches est utilisé.
- 1 x connecteur d'alimentation ATX 24 broches

- 1 x connecteur d'alimentation 12 V 8 broches
- 1 x connecteur audio panneau frontal
- 1 x embase USB 2.0 (2 ports USB 2.0 pris en charge) (Protection contre les décharges électrostatiques)
- 1 x embase USB 3.1 Gen1 (2 ports USB 3.1 Gen1 pris en charge) (Protection contre les décharges électrostatiques)

Caractéristiques du BIOS

- BIOS UEFI AMI avec prise en charge d'interface graphique multilingue
- Compatible ACPI 6.0 Wake Up Events
- Compatible SMBIOS 2.7
- Réglage de la tension DRAM, PCH 1,05V

Surveillance du matériel

- Détection de température : Ventilateurs de CPU / châssis / pompe à eau
- Tachymètre de ventilateur : Ventilateurs de CPU / châssis / pompe à eau
- Ventilateur silencieux (réglage automatique de la vitesse du ventilateur du châssis d'après la température du CPU) : Ventilateurs de CPU / châssis / pompe à eau
- Contrôle simultané des vitesses du ventilateur : Ventilateurs de CPU / châssis / pompe à eau
- Détection CHÂSSIS OUVERT
- Surveillance de la tension d'alimentation : +12V, +5V, +3,3V, CPU Vcore

Système d'exploitation

- Microsoft® Windows® 10 64 bits

Certifications

- FCC, CE
- ErP/EuP Ready (alimentation ErP/EuP ready requise)

Specifiche

- Piattaforma**
- Fattore di forma Micro ATX
 - Design condensatore solido

- CPU**
- Supporta processori 8th Generation Intel® Core™ (Socket 1151)
 - Potenza a 5 fasi
 - Supporta la tecnologia Intel® Turbo Boost 2.0

- Chipset**
- Intel® H310

- Memoria**
- Tecnologia memoria DDR4 Dual Channel
 - 2 x alloggi DIMM DDR4
 - Supporto di memoria DDR4 2666/2400/2133 non-ECC, unbuffered
 - Capacità max. della memoria di sistema: 32 GB
 - Supporto di XMP (Extreme Memory Profile) Intel® 2.0
 - Contatti d'oro 15µ negli alloggi DIMM

- Alloggio d'espansione**
- 1 x alloggiamento PCI Express 3.0 x16 (PCIe2:modalità x16)*
 - * Supporto di SSD NVMe come disco d'avvio
 - 1 x alloggiamento PCI Express 2.0 x1

- Grafica**
- La videografica integrata della scheda video UHD Intel® e le uscite VGA possono essere supportate soltanto con processori con GPU integrata.
 - Supporta la videografica integrata della scheda video UHD Intel®: Intel® Quick Sync Video con AVC, MVC (S3D) e MPEG-2 Full HW Encode1, Intel® InTru™ 3D, Intel® Clear Video HD Technology, Intel® Insider™, Intel® UHD Graphics
 - DirectX 12
 - Codifica/decodifica HWA: AVC/H.264, HEVC/H.265 8-bit, HEVC/H.265 10-bit, VP8, VP9 8-bit, VP9 10-bit (solo decodifica), MPEG2, MJPEG, VC-1 (solo decodifica)
 - Supporta DVI-D con una risoluzione max. fino a 1920 x 1200 a 60 Hz

- Supporto di HDCP con le porte DVI-D

Audio

- Audio HD 7.1 CH (codec audio Realtek ALC887)
- * Per configurare l'audio HD 7.1 canali, è necessario utilizzare un modulo pannello frontale audio HD ed attivare la funzione audio multicanale tramite il driver audio.
- Supporta protezione da sovratensione
- Cappucci audio ELNA

LAN

- 1 x PCIE LAN Gigabit 10/100/1000 Mb/s
- 1 x Realtek RTL8111H
- Supporto WOL (Wake-On-LAN)
- Supporta protezione da fulmini/scariche elettrostatiche
- Supporto Energy Efficient Ethernet 802.3az
- Supporto PXE

I/O pannello posteriore

- 1 x porta mouse/tastiera PS/2
- 1 x porta DVI-D
- 4 x porte USB 2.0 (supporto protezione da scariche elettrostatiche)
- 2 x porte USB 3.1 Gen1 (supporto protezione da scariche elettrostatiche)
- 1 x porta LAN RJ-45 con LED (ACT/LINK LED e SPEED LED)
- Connettori audio HD: Ingresso linea / altoparlante frontale / microfono

Archiviazione

- 4 x connettori SATA3 6,0 Gb/s supportano NCQ, AHCI e Hot Plug

Connettore

- 1 x connettore TPM
- 1 x collegamento altoparlante e intrusione telaio
- 1 x connettore ventola CPU (4-pin)
- * Il connettore ventola CPU supporta ventole CPU con potenza massima di 1 A (12 W).
- 1 x connettore ventola chassis/ventola pompa dell'acqua (4 pin) (Smart Fan Speed Control)

* La ventola pompa dell'acqua supporta ventole di sistemi di raffreddamento ad acqua di potenza massima di 2A (24W).

* CHA_FAN1/WP sono in grado di rilevare se è in uso una ventola a 3 pin o 4 a pin.

- 1 x connettore alimentazione ATX 24 pin
- 1 x connettore alimentazione 12 V 8-pin
- 1 x connettore audio pannello frontale
- 1 x connettore USB 2.0 (supporto di 2 porte USB 2.0) (supporto protezione da scariche elettrostatiche)
- 1 x connettore USB 3.1 Gen1 (supporto di 2 porte USB 3.1 Gen1) (supporto protezione da scariche elettrostatiche)

Funzionalità BIOS

- AMI UEFI Legal BIOS con interfaccia di supporto multilingue
- Eventi di riattivazione conformi a ACPI 6.0
- Supporto di SMBIOS 2.7
- Multiregolazione tensione DRAM, PCH 1,05 V

Hardware Monitor

- Sensore di temperatura: Ventole CPU, chassis, pompa dell'acqua
- Tachimetro ventola: Ventole CPU, chassis, pompa dell'acqua
- Ventola silenziosa (regolazione automatica velocità in base alla temperatura della CPU): Ventole CPU, chassis, pompa dell'acqua
- Controllo velocità ventola: Ventole CPU, chassis, pompa dell'acqua
- Rilevamento CASE OPEN
- Monitoraggio tensione: +12 V, +5 V, +3,3 V, CPU Vcore

SO

- Microsoft® Windows® 10 64 bit

Certificazioni

- FCC, CE
- ErP/EuP Ready (è necessaria alimentazione ErP/EuP ready)

Especificaciones

- Plataforma**
- Factor de forma Micro ATX
 - Diseño de condensador sólido

- CPU**
- Compatible con la 8ª generación de procesadores Intel® Core™ (Socket 1151)
 - Diseño de 5 fases de alimentación
 - Admite la tecnología Intel® Turbo Boost 2.0

- Conjunto de chips**
- Intel® H310

- Memoria**
- Tecnología de memoria DDR4 de doble canal
 - 2 x ranuras DIMM DDR4
 - Admite memoria DDR4 2666/2400/2133 no ECC, sin búfer
 - Capacidad máxima de memoria del sistema: 32 GB
 - Admite Perfil de memoria extremo de Intel® (XMP) 2.0
 - Contacto 15µ Gold en ranuras DIMM

- Ranura de expansión**
- 1 ranura PCI Express 3.0 x16 (PCIe2:modo x16)*
 - * Admite unidad de estado sólido de NVMe como disco de arranque
 - 1 x ranura PCI Express 2.0 x1

- Gráficos**
- Intel® UHD Graphics Built-in Visuals y las salidas de VGA son compatibles únicamente con procesadores con GPU integrado.
 - Admite Intel® UHD Graphics Built-in Visuals: Intel® Quick Sync Video con AVC, MVC (S3D) y MPEG-2 Full HW Encode1, Intel® InTru™ 3D, Intel® Clear Video HD Technology, Intel® Insider™, Intel® UHD Graphics
 - DirectX 12
 - Codificación y decodificación HWA: AVC/H.264, HEVC/H.265 8 bits, HEVC/H.265 10 bits, VP8, VP9 8 bits, VP9 10 bits (solo descodificar), MPEG2, MJPEG, VC-1 (solo descodificar)
 - Compatible con DVI-D con máxima resolución hasta 1920x1200 @ 60Hz

- Compatible con función HDCP con puertos DVI-D

Audio

- 7.1 Audio CH HD (Código de audio Realtek ALC887)
- *Para configurar 7.1 Audio CH HD, deberá utilizar un módulo del panel frontal de audio HD y habilitar la característica de audio multicanal a través del controlador de audio.
- Admite protección contra sobretensiones
 - Tapas de audio ELNA

LAN

- PCIE x1 Gigabit LAN 10/100/1000 Mb/s
- 1 x Realtek RTL8111H
- Admite la función Reactivación de LAN
- Admite protección contra rayos y descargas electrostáticas (ESD)
- Admite Ethernet 802.3az de eficiencia energética
- Admite PXE

E/S en panel posterior

- 1 x puerto de ratón/teclado PS/2
- 1 x puerto DVI-D
- 4 x Puertos USB 2.0 (admite protección contra descargas electrostáticas)
- 2 x Puertos USB 3.1 Gen1 (admite protección contra descargas electrostáticas)
- 1 x Puerto LAN RJ-45 con LED (LED DE ACTIVIDAD/ ENLACE y LED DE VELOCIDAD)
- Conector de audio HD: Entrada de línea / Altavoz frontal / Micrófono

Almacenamiento

- 4 conectores SATA3 de 6,0 Gb/s, compatibles con las funciones NCQ, AHCI y Conexión en caliente

Conector

- 1 x Conector TPM
 - 1 x cabezal de intrusión de chasis y de altavoces
 - 1 x Conector para ventilador de la CPU (4 contactos)
- * El conector para ventilador de la CPU admite ventilador de la CPU con una potencia de ventilador de 1 A (12 W) máxima.
- 1 x Conector (4 contactos) para el ventilador de la bomba de agua/chasis (control de velocidad de ventilador inteligente)
- * El ventilador de la bomba de agua/opcional del chasis admite ventilador del disipador por agua con una potencia de ventilador máxima de 2A (24 W).

* CHA_FAN1/WP se pueden detectar automáticamente si se usa el ventilador de 3 o 4 pines.

- 1 x conector de alimentación ATX de 24 contactos
- 1 x conector de alimentación de 12V de 8 pines
- 1 x Conector de audio en el panel frontal
- 1 x base de conexiones USB 2.0 (admite 2 puertos USB 2.0). Admite protección contra descargas electrostáticas.
- 1 x base de conexiones USB 3.1 Gen1 (admite 2 puertos USB 3.1 Gen1). Admite protección contra descargas electrostáticas.

Función de la BIOS

- BIOS legal UEFI AMI compatible con interfaz gráfica de usuario multilingüe
- Eventos de reactivación compatibles con ACPI 6.0
- Admite SMBIOS 2.7
- Multiajuste de voltaje de DRAM, PCH 1,05V

Monitor de hardware

- Detección de temperatura: Ventiladores de la bomba de agua/chasis/CPU
- Tacómetro del ventilador: Ventiladores de la bomba de agua/chasis/CPU
- Ventilador silencioso (ajuste automático de la velocidad del ventilador del chasis por temperatura de la CPU): Ventiladores de la bomba de agua/chasis/CPU
- Control de varias velocidades del ventilador: Ventiladores de la bomba de agua/chasis/CPU
- Detección de CARCASA ABIERTA
- Supervisión del voltaje: +12 V, +5 V, +3,3 V, Vcore de CPU

SO

- Microsoft® Windows® 10 64 bits

Certificaciones

- FCC y CE
- Preparado para ErP/EuP (se necesita una fuente de alimentación preparada para ErP/EuP)

Спецификация

Платформа	<ul style="list-style-type: none">• Форм-фактор Micro ATX• Схема на основе твердотельных конденсаторов
ЦП	<ul style="list-style-type: none">• Поддержка процессоров 8^{го} поколения Intel® Core™ (Socket 1151)• Система питания 5• Поддерживается технология Intel® Turbo Boost 2.0
Чипсет	<ul style="list-style-type: none">• Intel® H310
Память	<ul style="list-style-type: none">• Двухканальная память DDR4• 2 гнезда DDR4 DIMM• Поддерживаются модули небуферизованной памяти DDR4 2666/2400/2133 без ECC.• Максимальный объем ОЗУ: 32 ГБ• Поддерживается Intel® Extreme Memory Profile (XMP) 2.0• Позолоченные (15 мкм) контакты слотов DIMM
Слот расширения	<ul style="list-style-type: none">• 1 слот PCI Express 3.0 x16 (PCIe2:режим x16)* <p>* Поддерживаются в качестве загрузочных SSD-диски типа NVMe.</p> <ul style="list-style-type: none">• 1 слот PCI Express 2.0 x1
Графическая подсистема	<ul style="list-style-type: none">• Встроенный видеоадаптер Intel® UHD Graphics и выходы VGA поддерживаются только при использовании ЦП со встроенными графическими процессорами.• Поддерживаемые встроенные технологии визуализации Intel® UHD Graphics: Intel® Quick Sync Video с полностью аппаратным кодированием¹ в форматах AVC, MVC (S3D) и MPEG-2, Intel® InTru™ 3D, технология Intel® Clear Video HD, Intel® Insider™, Intel® UHD Graphics• DirectX 12• Программно-аппаратное кодирование-декодирование: AVC/H.264, HEVC/H.265 8 бит, HEVC/H.265 10 бит, VP8, VP9 8 бит, VP9 10 бит (только декодирование), MPEG2, MJPEG, VC-1 (только декодирование)• На выходе DVI-D поддерживается максимальное разрешение до 1920x1200 при частоте обновления 60 Гц• Поддержка функции защиты HDCP через порты DVI-D

Звук

- 7.1-канальный звук высокой четкости (аудиокодек Realtek ALC887)

*Для настройки 7.1-канального звука высокой четкости HD Audio используйте переднюю аудиопанель HD и активируйте функцию многоканального звука в аудиодрайвере.

- Защита от перепадов напряжения в электрической сети
- Конденсаторы для аудиосистем ELNA

LAN

- PCIE x1 Gigabit LAN 10/100/1000 Мбит/с
- 1 Realtek RTL8111H
- Поддерживается пробуждение по ЛВС
- Молниезащита и защита от электростатических разрядов
- Поддерживается Energy Efficient Ethernet 802.3az
- Поддерживается PXE

Порты ввода-вывода на задней панели

- 1 порт PS/2 для мыши/клавиатуры
- 1 порт DVI-D
- 4 портов USB 2.0 (с защитой от электростатических разрядов)
- 2 портов USB 3.1 Gen1 (с защитой от электростатических разрядов)
- 1 порт ЛВС RJ-45 с индикаторами («Активность/Соединение» и «Скорость»)
- Разъемы HD Audio: Линейный вход / передние динамики / микрофон

Запоминающие устройства

- 4 порта SATA3 6,0 Гбит/с, поддерживаются NCQ, АHCI и «горячая» замена

Разъемы

- 1 колодка TPM
- 1 колодка с разъемами датчика вскрытия корпуса и динамика
- 1 разъем для вентилятора охлаждения ЦП, 4-контактный
- * Разъем процессорного вентилятора поддерживает вентилятор с потребляемым током не более 1 А (12 Вт).
- 1 разъем для корпусного вентилятора или водяной помпы (4-контактный) (смарт-регулятор скорости вентилятора)
- * Разъем для дополнительного корпусного вентилятора или водяной помпы поддерживает вентилятор с потребляемым током не более 2А (24 Вт).
- * Для разъемов CHA_FAN1/WP автоматически определяется тип подключенного вентилятора: 3- или 4-контактный.

- 1 разъем питания ATX, 24-контактный
- 1 разъем питания 12 В, 8-контактный
- 1 аудиоразъем на передней панели
- 1 колодка USB 2.0 (2 порта USB 2.0 с защитой от электростатических разрядов)
- 1 колодка USB 3.1 Gen1 (2 порта USB 3.1 Gen1) (с защитой от электростатических разрядов)

Параметры BIOS

- AMI UEFI Legal BIOS с поддержкой многоязычного графического интерфейса
- Поддержка функций пробуждения по стандарту ACPI 6.0
- Поддержка SMBIOS 2.7
- Регулировка напряжений DRAM, PCN 1,05 В

Контроль оборудования

- Контроль температуры: вентилятор ЦП; корпусной вентилятор или помпа водяного охлаждения корпуса
- Тахометр: вентилятор ЦП; корпусной вентилятор или помпа водяного охлаждения корпуса
- Бесшумная работа (с автоматической регулировкой скорости вращения в зависимости от температуры ЦП): вентилятор ЦП; корпусной вентилятор или помпа водяного охлаждения корпуса
- Регулировка скорости вращения: вентилятор ЦП; корпусной вентилятор или помпа водяного охлаждения корпуса
- Датчик вскрытия корпуса
- Контроль напряжений: +12 В, +5 В, +3,3 В, Vcore ЦП

Операционные системы

- Microsoft® Windows® 10 (64-разрядная)

Сертификация

- FCC, CE
- Совместимость с ErP/EuP (необходим блок питания, соответствующий стандарту ErP/EuP)

Especificações

- Plataforma**
- Micro ATX Form Factor
 - Design de condensador sólido

- CPU**
- Suporta 8ª Geração de Processadores Intel® Core™ (Soquete 1151)
 - Design com 5 fases de alimentação
 - Suporta a tecnologia Intel® Turbo Boost 2.0

- Chipset**
- Intel® H310

- Memória**
- Tecnologia de memória DDR4 de dois canais
 - 2 x Slots DIMM DDR4
 - Suporta memória DDR4 2666/2400/2133, não ECC, sem memória intermédia
 - Capacidade máxima da memória do sistema: 32GB
 - Suporta Extreme Memory Profile (XMP) 2.0 da Intel®
 - Contato em Ouro 15µ nos slots DIMM

- Slot de expansão**
- 1 x Slot PCI Express 3.0 x16 (PCIe2:modo x16)*
 - * Suporta NVMe SSD nos discos de inicialização
 - 1 x Slot PCI Express 2.0 x1

- Gráficos**
- Os gráficos incorporados Intel® UHD e as saídas VGA só podem ser suportados com processadores com GPU integrada.
 - Suporta gráficos incorporados Intel® UHD: Intel® Quick Sync Video com AVC, MVC (S3D) e MPEG-2 Full HW Encode1, Intel® InTru™ 3D, Tecnologia Intel® Clear Video HD, Intel® Insider™, Gráficos Intel® UHD
 - DirectX 12
 - HWAEncode/Decode: AVC/H.264, HEVC/H.265 8-bit, HEVC/H.265 10-bit, VP8, VP9 8-bit, VP9 10-bit (Decodificar apenas), MPEG2, MJPEG, VC-1 (Decodificar apenas)
 - Suporta DVI-D com resolução máxima de até 1920x1200 @ 60Hz

- Suporta HDCP com Portas DVI-D

Áudio

- Áudio 7.1 CH HD com proteção de conteúdo (Codec de áudio Realtek ALC887)

*Para configurar Áudio 7.1 CH HD, é necessário usar um módulo de áudio de painel frontal HD e habilitar o recurso de áudio multi-canal pelo driver de áudio.

- Suporta Proteção de Sobretenção
- Fones de Áudio ELNA

LAN

- LAN Gigabit 10/100/1000 Mb/s PCIE x1
- 1 x Realtek RTL8111H
- Suporta Wake-On-LAN
- Oferece Suporte à Proteção de Relâmpago/ESD
- Suporta Energy Efficient Ethernet 802.3az
- Suporta PXE

E/S do painel posterior

- 1 x Porta PS/2 para mouse/teclado
- 1 x Porta DVI-D
- 4 x Portas USB 2.0 (Suporta Proteção ESD)
- 2 x Portas USB 3.1 Gen1 (Suporta Proteção ESD)
- 1 x Porta LAN RJ-45 com LED (LED ACT/LINK e LED DE VELOCIDADE)
- Fichas de áudio HD: Entrada de Linha / Autofalante Frontal / Microfone

Armazenamento

- 4 x Conectores SATA3 6,0 Gb/s, suporte NCQ, AHCI, Conector a Quente

Conector

- 1 x Plataforma TPM
 - 1 x Intrusão do Chassi e Cabeçote de Autofalante
 - 1 x Conector da ventoinha da CPU (4 pinos)
- * O Conector do Ventilador de CPU suporta o ventilador de CPU de alimentação máxima 1A do ventilador (12W).
- 1 x Conector do ventilador do chassi/Ventilador da Bomba de Água (4 pinos) (Controle de Velocidade de Ventoinha Inteligente)

- * O Ventilador de Chassi Ventilador da Bomba de Água suporta o ventilador de refrigerador a água de 2A máximo (24W) potência do ventilador.
- * CHA_FAN1/WP podem detectar automaticamente se ventoinha de 3 pinos ou 4 pinos está em uso.
 - 1 x Conector alimentação ATX 24 pinos
 - 1 x Conector de energia 8-pinos 12V
 - 1 x Conector de áudio do painel frontal
 - 1 x Plataforma USB 2.0 (Suporta 2 portas USB 2.0) (Suporta Proteção ESD)
 - 1 x Plataforma USB 3.1 Gen1 (Suporta 2 portas USB 3.1 Gen1) (Suporta Proteção ESD)

Funções da BIOS

- AMI Legal UEFI BIOS com suporte multilingue GUI
- ACPI 6.0 compatível com eventos de despertar
- Suporte SMBIOS 2.7
- DRAM, PCH multi-ajuste de tensão 1,05V

Monitor de hardware

- Sensor de Temperatura: Ventilador da CPU, Chassis/Bomba de Água
- Tacômetro da ventoinha: Ventilador da CPU, Chassis/Bomba de Água
- Ventoinha Silenciosa (Auto ajusta velocidade da ventoinha do chassi pela temperatura da CPU): Ventilador da CPU, Chassis/Bomba de Água
- Controle multi-velocidade da ventoinha: Ventilador da CPU, Chassis/Bomba de Água
- Detecção de ABERTURA da CAIXA
- Monitoramento da tensão: +12V, +5V, +3,3V, CPU Vcore

SO

- Microsoft® Windows® 10 64-bit

Certificações

- FCC, CE
- Preparada para ErP/EuP (é necessária uma fonte de alimentação preparada para ErP/EuP)

Özellikler

Platform

- Micro ATX Form Faktörü
- Yekpare Kapasitör tasarımı

İşlemci

- 8. Nesil Intel® Core™ İşlemcileri (Yuva 1151) destekler
- 5 Güç Safhası tasarımı
- Intel® Turbo Boost 2.0 Teknolojisini destekler

Yonga kümesi

- Intel® H310

Bellek

- Çift Kanallı DDR4 Bellek Teknolojisi
- 2 tane DDR4 DIMM Yuvası
- DDR4 2666/2400/2133 ECC olmayan, arabelleksiz bellek
- En fazla sistem belleği kapasitesi: 32GB
- Intel® Üstün Bellek Profili (XMP) 2.0 destekler
- DIMM Yuvalarında 15 µ Altın Temas

Genişletme

Yuvası

- 1 tane PCI Express 3.0 x16 Yuva (PCIe2:x16 modu)*
- * Önyükleme diskleri olarak NVMe SSD destekler
- 1 tane PCI Express 2.0 x1 yuva

Grafikler

- Intel® UHD Graphics Dâhili Görselleri ile VGA çıktıları, yalnızca GPU entegre edilmiş işlemciler ile desteklenir.
- Intel® UHD Graphics Yerleşik Görsellerini destekler: AVC, MVC (S3D) ve MPEG-2 Full HW Encode1, Intel® InTru™ 3D, Intel® Net Video HD Teknolojisi, Intel® Insider™, Intel® UHD Graphics ile Intel® Quick Sync Video
- DirectX 12
- HWA Kodlama/Kod Çözme: AVC/H.264, HEVC/H.265 8 bit, HEVC/H.265 10 bit, VP8, VP9 8 bit, VP9 10 bit (yalnızca Kod Çözme), MPEG2, MJPEG, VC-1 (yalnızca Kod Çözme)
- En fazla 1920x1200 @ 60 Hz çözünürlükle DVI-D destekler
- DVI-D Bağlantı Noktalarıyla HDCP destekler

Ses

- 7.1 CH HD Ses (Realtek ALC887 Ses Kodlayıcı)
- * 7.1 CH HD Ses yapılandırması için, bir HD ön panel ses modülünün kullanılması ve çok kanallı ses özelliğinin ses sürücüsü aracılığıyla etkinleştirilmesi gereklidir.
- Aşırı Gerilim Korumasını destekler
- ELNA Ses Kapakları

LAN

- PCIE x1 Gigabit LAN 10/100/1000 Mb/sn.
- 1 x Realtek RTL8111H
- Yerel Ağ Üzerinden Açmayı destekler
- Yıldırım/ESD Korumasını destekler
- Enerji Verimliliğine Sahip Ethernet 802.3az işlevini destekler
- PXE özelliğini destekler

**Arka Panel
G/Ç**

- 1 tane PS/2 Fare/Klavye Bağlantı Noktası
- 1 tane DVI-D Bağlantı Noktası
- 4 tane USB 2.0 Bağlantı Noktası (ESD Korumasını destekler)
- 2 tane USB 3.1 Gen1 Bağlantı Noktası (ESD Korumasını destekler)
- 1 tane RJ-45 LAN LED'e sahip Bağlantı Noktası (ACT/LINK LED ve SPEED LED)
- HD Ses Girişleri/Çıkışları: Hat Girişi / Ön Hoparlör / Mikrofon

Depolama

- 4 x SATA3 6,0 Gb/sn Bağlayıcı, NCQ, AHCI ve Tak Çalıştır destekler

Bağlayıcı

- 1 tane TPM Bağlantısı
- 1 tane Kasa Yetkisiz Erişim ve Hoparlör Bağlantısı
- 1 tane İşlemci Fanı Bağlayıcı (4 pimli)
- * İşlemci Fanı Bağlayıcı, en fazla 1 A (12 W) fan gücünde işlemci fanı destekler.
- 1 tane Kasa Bağlı/Su Pompalı Fan Bağlayıcı (4 pimli) (Akıllı Fan Hızı Kontrolü)
- * Kasa İsteğe Su Pompalı Fan, en fazla 2A (24 W) fan gücünde su soğutmalı fan destekler.
- * CHA_FAN1/WP, 3 pimli fanın mı yoksa 4 pimli fanın mı kullanımında olduğunu otomatik olarak algılayabilir.
- 1 tane 24 pim ATX Güç Bağlayıcısı
- 1 tane 8 pim 12 V Güç Bağlayıcısı
- 1 tane Ön Panel Ses Bağlayıcısı

- 1 tane USB 2.0 Bağlantısı (2 USB 2.0 bağlantı noktasını destekler) (ESD Korumasını destekler)
- 1 tane USB 3.1 Gen1 Bağlantısı (2 USB 3.1 Gen1 bağlantı noktasını destekler) (ESD Korumasını destekler)

BIOS Özelliği

- Çok dilli kullanıcı arayüzü desteğiyle AMI UEFI Legal BIOS
- ACPI 6.0 Uyumlu uyandırma olayları
- SMBIOS 2.7 Desteği
- DRAM, PCH 1,05 V Voltaj çoklu ayarı

Donanım Monitörü

- Sıcaklık Algılama: İşlemci, Kasa/Su Pompalı Fanlar
- Fan Devirölçer: İşlemci, Kasa/Su Pompalı Fanlar
- Sessiz Fan (İşlemci sıcaklığıyla otomatik ayarlanan kasa fanı hızı): İşlemci, Kasa/Su Pompalı Fanlar
- Fan Çoklu Hız Kontrolü: İşlemci, Kasa/Su Pompalı Fanlar
- KASA AÇIK algılaması
- Gerilim izleme: +12 V, +5 V, +3,3 V, İşlemci Vcore

İşletim Sistemi

- Microsoft® Windows® 10 64 bit

Onaylar

- FCC, CE
- ErP/EuP için hazır (ErP/EuP için hazır güç beslemesi gereklidir)

규격

플랫폼

- Micro ATX 폼 팩터
- 솔리드 콘텐서 구조

CPU

- 8 세대 Intel® Core™ 프로세서 지원 (소켓 1151)
- 5 개 전원 위상 구조
- Intel® Turbo Boost 2.0 기술 지원

칩세트

- Intel® H310

메모리

- 듀얼 채널 DDR4 메모리 기술
- DDR4 DIMM 슬롯 2 개
- DDR4 2666/2400/2133 비 ECC, 비버퍼링 메모리 지원
- 시스템 메모리 최대 용량 : 32GB
- Intel® Extreme Memory Profile (XMP) 2.0 지원
- DIMM 슬롯에 15 μ Gold Contact 장착

확장 슬롯

- PCI Express 3.0 x16 슬롯 1 개 (PCIe2:x16 모드)*
- * NVMe SSD 를 부팅 디스크로 사용 가능하도록 지원
- PCI Express 2.0 x1 슬롯 1 개

그래픽

- Intel® UHD 그래픽스 빌트 - 인 비주얼과 VGA 출력은 GPU 통합 프로세서로만 지원할 수 있습니다.
- Intel® UHD 그래픽스 빌트 - 인 비주얼 지원 : AVC, MVC (S3D) 및 MPEG-2 풀 HW Encode1 지원 Intel® Quick Sync Video, Intel® InTru™ 3D, Intel® 클리어 비디오 HD 기술, Intel® Insider™, Intel® UHD 그래픽스
- DirectX 12
- HWA 인코드 / 디코드 : AVC/H.264, HEVC/H.265 8- 비트, HEVC/H.265 10- 비트, VP8, VP9 8- 비트, VP9 10- 비트 (디코딩 전용), MPEG2, MJPEG, VC-1 (디코딩 전용)
- DVI-D 지원 (최대 해상도 1920x1200 @ 60Hz)
- DVI-D 포트를 이용한 HDCP 지원

오디오

- 7.1 CH HD 오디오 (Realtek ALC887 오디오 코덱)
- * 7.1 CH HD 오디오를 구성하려면 HD 전면 채널 오디오 모듈을 사용하고 다채널 오디오 기능을 오디오 드라이버로 활성화해야 합니다.

- 서비 보호 지원
- ELNA 오디오 캡

LAN

- PCIE 1 개 , Gigabit LAN 10/100/1000 Mb/s
- 1 x Realtek RTL8111H
- Wake-On-LAN 지원
- 번개 /ESD 보호 지원
- 절전형 이더넷 802.3az 지원
- PXE 지원

후면 패널 I/O

- PS/2 마우스 / 키보드 포트 1 개
- DVI-D 포트 1 개
- USB 2.0 포트 4 개 (ESD 보호 지원)
- USB 3.1 Gen1 포트 2 개 (ESD 보호 지원)
- LED 장착 RJ-45 LAN 포트 1 개 (ACT/LINK LED 및 SPEED LED)
- HD 오디오 잭 : 라인 입력 / 전면 스피커 / 마이크

저장 장치

- SATA3 6.0 Gb/s 커넥터 4 개 , NCQ, AHCI 및 “ 핫 플러그 ” 지원

커넥터

- TPM 헤더 1 개
- 새시 침입 및 스피커 헤더 1 개
- CPU 팬 커넥터 (4 핀) 1 개
- * CPU 팬 커넥터는 팬 전력이 최대 1A(12W) 인 CPU 팬을 지원 합니다.
- 새시 / 워터 펌프 팬 커넥터 (4 핀) 1 개 (스마트 팬 속도 제어)
- * 새시워터 펌프 팬은 팬 전력이 최대 2A(24W) 인 수냉식 쿨러 팬을 지원 합니다.
- * 3 핀 또는 4 핀 팬이 사용 중인 경우 , CHA_FAN1/WP 가 자동으로 감지할 수 있습니다.
- 24 핀 ATX 전원 커넥터 1 개
- 8 핀 12V 전원 커넥터 1 개
- 전면 패널 오디오 커넥터 1 개
- USB 2.0 헤더 1 개 (USB 2.0 포트 2 개 지원) (ESD 보호 지원)

- USB 3.1 Gen1 헤더 1 개 (USB 3.1 Gen1 포트 2 개 지원) (ESD 보호 지원)

BIOS 기능

- 다국어 GUI 지원을 제공하는 AMI UEFI 적합형 BIOS
- ACPI 6.0 준수 웨이크 업 이벤트
- SMBIOS 2.7 지원
- DRAM, PCH 1.05V, 전압 다중 조정

**하드웨어
모니터**

- 온도 감지 : CPU, 새시 / 워터 펌프 팬
- 팬 타코미터 : CPU, 새시 / 워터 펌프 팬
- 저소음 팬 (CPU 온도에 의한 새시 팬 속도 자동 조절): CPU, 새시 / 워터 펌프 팬
- 팬 다중 속도 제어 : CPU, 새시 / 워터 펌프 팬
- 케이스 열림 감지
- 전압 모니터링 : +12V, +5V, +3.3V, CPU Vcore

OS

- Microsoft® Windows® 10 64- 비트

인증

- FCC, CE
- ErP/EuP 사용 가능 (ErP/EuP 사용 가능 전원공급장치 필요)

仕様

- プラットフォーム**
- ・ マイクロ ATX フォームファクター
 - ・ 固体コンデンサ設計

- CPU**
- ・ 第 8 世代 Intel® Core™ プロセッサに対応(ソケット 1151)
 - ・ 5 電源フェーズ設計
 - ・ Intel® ターボブースト 2.0 テクノロジーをサポート

- チップセット**
- ・ Intel® H310

- メモリ**
- ・ デュアルチャンネル DDR4 メモリ機能
 - ・ 2 x DDR4 DIMM スロット
 - ・ DDR4 2666/2400/2133 ノン ECC、アンバッファードメモリに対応
 - ・ システムメモリの最大容量: 32GB
 - ・ Intel® エクストリームメモリプロファイル(XMP)2.0 に対応
 - ・ DIMM スロットに 15 μ ゴールドコンタクトを採用

- 拡張スロット**
- ・ 1 x PCI Express 3.0 x16 スロット(PCIe2:x16 モード)*
 - * 起動ディスクとして NVMe SSD に対応
 - ・ 1 x PCI Express 2.0 x1 スロット

- グラフィックス**
- ・ Intel® UHD グラフィックス内蔵ビジュアルおよび VGA 出力は、GPU に統合されたプロセッサのみでサポートされます。
 - ・ Intel® UHD グラフィックス内蔵ビジュアルをサポート: AVC、MVC (S3D) および MPEG-2 Full HW Encode1 が装備された Intel® クイック・シンク・ビデオ、Intel® InTru™ 3D、Intel® クリアー・ビデオ HD テクノロジー、Intel® Insider™、Intel® UHD グラフィックス
 - ・ DirectX 12
 - ・ HWA エンコード / デコード: AVC/H.264、HEVC/H.265 8-ビット、HEVC/H.265 10-ビット、VP8、VP9 8-ビット、VP9 10-ビット(デコードのみ)、MPEG2、MJPEG、VC-1(デコードのみ)
 - ・ DVI-D に対応、最大解像度 1920x1200 @60Hz

- DVI-D ポートで HDCP に対応

オーディオ

- 7.1 CH HD オーディオ (Realtek ALC887 Audio Codec)
- *7.1 CH HD オーディオを設定するためには、HD フロントパネルのオーディオモジュールを使用し、オーディオドライバを通してマルチチャンネルオーディオ機能を有効にする必要があります。
- サージ保護に対応
- ELNA 製オーディオコンデンサ

LAN

- PCIE x1 ギガビット LAN 10/100/1000 Mb/ 秒
- 1 x Realtek RTL8111H
- Wake-On-LAN(ウェイク オン ラン)に対応
- 雷 / 静電気放電(ESD)保護に対応
- エネルギー効率のよいイーサネット 802.3az をサポート
- PXE をサポート

リアパネル I/O

- 1 x PS/2 マウス / キーボードポート
- 1 x DVI-D ポート
- 4 x USB 2.0 ポート (静電気放電 (ESD) 保護に対応)
- 2 x USB 3.1 Gen1 ポート (静電気放電 (ESD) 保護に対応)
- LED 付き 1 x RJ-45 LAN ポート (ACT/LINK LED と SPEED LED)
- HD オーディオジャック : ラインイン / フロントスピーカー / マイク

ストレージ

- 4 x SATA3 6.0 Gb/s コネクタ、NCQ、AHCI、および、ホットプラグ機能に対応

コネクタ

- 1 x TPM ヘッダー
- 1 x シャーシインテリジェンとスピーカーヘッダー
- 1 x CPU ファンコネクタ (4 ピン)
- * CPU ファンコネクタは最大 1A (12W) の電力の CPU ファンに対応します。
- 1 x シャーシ / ウォーターポンプファンコネクタ (4 ピン) (スマートファン速度制御)

* シャーシ / ウォーターポンプファンは最大 2A (24W) の出力のウォータークーラーに対応します。

* CHA_FAN1/WP は 3 ピンまたは 4 ピンファンが使用されているかどうかを自動検出できます。

- 1 x 24 ピン ATX 電源コネクタ
- 1 x 8 ピン 12V 電源コネクタ
- 1 x 前面パネルオーディオコネクタ
- 1 x USB 2.0 ヘッダー (2 つの USB 2.0 ポートに対応) (静電気放電 (ESD) 保護に対応)
- 1 x USB 3.1 Gen1 ヘッダー (2 つの USB 3.1 Gen1 ポートに対応) (静電気放電 (ESD) 保護に対応)

BIOS 機能

- AMI UEFI Legal BIOS、多言語 GUI サポート付き
- ACPI 6.0 準拠ウェイクアップイベント
- SMBIOS 2.7 サポート
- DRAM、PCH 1.05V、複数電圧設定

ハードウェア モニター

- 温度センシング: CPU、シャーシ / ウォーターポンプファン
- ファンタコメータ: CPU、シャーシ / ウォーターポンプファン
- 静音ファン (CPU 温度に従ってシャーシファン速度を自動調整): CPU、シャーシ / ウォーターポンプファン
- ファンマルチ速度制御: CPU、シャーシ / ウォーターポンプファン
- ケース開閉検知
- 電圧監視: +12V、+5V、+3.3V、CPU Vcore

OS

- Microsoft® Windows® 10 64-bit

認証

- FCC、CE
- ErP/EuP Ready (ErP/EuP 対応電源供給装置が必要です)

规格

平台

- Micro ATX 规格尺寸
- 稳固的电容器设计

CPU

- 支持第 8 代 Intel® Core™ 处理器（插座 1151）
- 5 电源相设计
- 支持 Intel® Turbo Boost 2.0 技术

芯片集

- Intel® H310

内存

- 双通道 DDR4 内存技术
- 2 x DDR4 DIMM 槽
- 支持 DDR4 2666/2400/2133 非 ECC，非缓冲内存
- 支持系统内存最大容量：32GB
- 支持 Intel® Extreme Memory Profile (XMP) 2.0
- DIMM 插槽中 15 μ 金触点

扩充槽

- 1 x PCI Express 3.0 x16 插槽（PCIE2：x16 模式）*
- * 支持 NVMe SSD 用作启动盘
- 1 x PCI Express 2.0 x1 槽

图形

- 只有 GPU 集成的处理器才支持 Intel® UHD Graphics 内置视效和 VGA 输出。
- 支持 Intel® UHD Graphics 内置视效：Intel® 快速同步视频，采用 AVC、MVC (S3D) 和 MPEG-2 Full HW Encode1、Intel® InTru™ 3D、Intel® Clear Video HD 技术、Intel® Insider™、Intel® UHD Graphics
- DirectX 12
- HWA 编码 / 解码：AVC/H.264、HEVC/H.265 8-bit、HEVC/H.265 10-bit、VP8、VP9 8-bit、VP9 10-bit（仅解码）、MPEG2、MJPEG、VC-1（仅解码）
- 支持 DVI-D，60Hz 时最大分辨率达 1920x1200
- 通过 DVI-D 端口支持 HDCP

音频

- 7.1 CH 高清音频 (Realtek ALC887 音频编解码器)
- * 要配置 7.1 CH 高清音频，需要使用高清前面板模块和通过音频驱动程序启用多通道音频功能。
- 支持电涌保护
- ELNA 音频电容

LAN

- PCIE x1 Gigabit LAN 10/100/1000 Mb/s
- 1 x Realtek RTL8111H
- 支持 Wake-On-LAN (网上唤醒)
- 支持雷电 / ESD 保护
- 支持高能效以太网 802.3az
- 支持 PXE

后面板 I/O

- 1 x PS/2 鼠标 / 键盘端口
- 1 x DVI-D 端口
- 4 x USB 2.0 端口 (支持 ESD 保护)
- 2 x USB 3.1 Gen1 端口 (支持 ESD 保护)
- 1 x RJ-45 LAN 端口，带 LED (ACT/LINK LED 和 SPEED LED)
- 高清音频插孔: 线路输入 / 前扬声器 / 麦克风

存储

- 4 x SATA3 6.0 Gb/s 接口，支持 NCQ、AHCI 和热插拔

接口

- 1 x TPM 接脚
- 1 x 机箱侵入和扬声器接脚
- 1 x CPU 风扇接口 (4 针)
- * CPU 风扇接口支持最高 1A (12W) 功率的 CPU 风扇。
- 1 x 机箱 / 水泵风扇接口 (4 针) (智能风扇速度控制)
- * 机箱水泵风扇支持最高 2A (24W) 功率的水冷风扇。
- * CHA_FAN1/WP 可以自动检测 3 针脚或 4 针脚风扇是否在使用。
- 1 x 24 针 ATX 电源接口
- 1 x 8 针 12V 电源接口
- 1 x 前面板音频接口
- 1 x USB 2.0 接脚 (支持 2 个 USB 2.0 端口，支持 ESD 保护)
- 1 x USB 3.1 Gen1 接脚 (支持 2 个 USB 3.1 Gen1 端口，支持 ESD 保护)

BIOS**功能特点**

- AMI UEFI Legal BIOS，支持多语言 GUI
- ACPI 6.0 兼容唤醒事件
- SMBIOS 2.7 支持
- DRAM, PCH 1.05V 电压多次调整（Voltage Multi-adjustment）

硬件监控

- 温度感测：CPU、机箱 / 水泵风扇
- 风扇转速计：CPU、机箱 / 水泵风扇
- 静音风扇（根据 CPU 温度自动调整机箱风扇速度）：CPU、机箱 / 水泵风扇
- 风扇多种速度控制：CPU、机箱 / 水泵风扇
- CASE OPEN（机箱打开）检测
- 电压监控：+12V、+5V、+3.3V、CPU Vcore

操作系统

- Microsoft® Windows® 10 64-bit

认证

- FCC、CE
- ErP/EuP 支持（需要支持 ErP/EuP 的电源）

电子信息产品污染控制标示

依据中国发布的「电子信息产品污染控制管理办法」及 SJ/T 11364-2006「电子信息产品污染控制标示要求」，电子信息产品应进行标示，藉以向消费者揭露产品中含有的有毒有害物质或元素不致发生外泄或突变从而对环境造成污染或对人体、财产造成严重损害的期限。依上述规定，您可于本产品之印刷电路板上看见图一之标示。图一中之数字为产品之环保使用期限。由此可知此主板之环保使用期限为 10 年。



图一

有毒有害物质或元素的名称及含量说明

若您欲了解此产品的有毒有害物质或元素的名称及含量说明，请参照以下表格及说明。

部件名称	有害物质或元素					
	铅 (Pb)	镉 (Cd)	汞 (Hg)	六价铬 (Cr(VI))	多溴联苯 (PBB)	多溴二苯醚 (PBDE)
印刷电路板及电子组件	X	O	O	O	O	O
外部信号连接头及线材	X	O	O	O	O	O

O: 表示该有毒有害物质在该部件所有均质材料中的含量均在 SJ/T 11363-2006 标准规定的限量要求以下。

X: 表示该有毒有害物质至少在该部件的某一均质材料中的含量超出 SJ/T 11363-2006 标准规定的限量要求，然该部件仍符合欧盟指令 2002/95/EC 的规范。

备注: 此产品所标示之环保使用期限，系指在一般正常使用状况下。

規格

- 平台**
- Micro ATX 尺寸
 - 固態電容設計

- CPU**
- 支援第 8 代 Intel® Core™ 處理器 (Socket 1151)
 - 5 電源相位設計
 - 支援 Intel® Turbo Boost 2.0 技術

- 晶片組**
- Intel® H310

- 記憶體**
- 雙通道 DDR4 記憶體技術
 - 2 x DDR4 DIMM 插槽
 - 支援 DDR4 2666/2400/2133 非 ECC 無緩衝記憶體
 - 最大系統記憶體容量：32GB
 - 支援 Intel® Extreme Memory Profile (XMP) 2.0
 - 15 μ 特厚鍍金插槽

- 擴充插槽**
- 1 x PCI Express 3.0 x16 插槽 (PCIe2：x16 模式)*
 - * 支援 NVMe SSD 作為開機磁碟
 - 1 x PCI Express 2.0 x1 插槽

- 顯示卡**
- 僅限整合 GPU 的處理器才可支援 Intel® UHD Graphics Built-in Visuals 及 VGA 輸出。
 - 支援 Intel® UHD Graphics Built-in Visuals：轉換 AVC、MVC (S3D) 及 MPEG-2 Full HW Encode1 的 Intel® 高速影像同步轉檔技術、Intel® InTru™ 3D, Intel® Clear Video HD Technology、Intel® Insider™、Intel® UHD Graphics
 - DirectX 12
 - HWA 編碼 / 解碼：AVC/H.264, HEVC/H.265 8 位元、HEVC/H.265 10 位元、VP8, VP9 8 位元、VP9 10 位元 (僅解碼)、MPEG2、MJPEG、VC-1 (僅解碼)
 - 支援最高達 1920x1200 @ 60Hz 解析度的 DVI-D
 - 支援含 DVI-D 連接埠的 HDCP

音訊

- 7.1 CH HD 音訊 (Realtek ALC887 音訊轉碼器)
- * 若要設定 7.1 CH HD 音訊，必須使用 HD 前面板音訊模組，並透過音訊驅動程式啟用多聲道音訊功能。
- 支援突波保護
- ELNA 音響級電容

LAN

- PCIE x1 Gigabit LAN 10/100/1000 Mb/s
- 1 x Realtek RTL8111H
- 支援網路喚醒
- 支援雷擊／靜電保護
- 支援 Energy Efficient Ethernet 802.3az
- 支援 PXE

後面板 I/O

- 1 x PS/2 滑鼠／鍵盤連接埠
- 1 x DVI-D 連接埠
- 4 x USB 2.0 連接埠 (支援靜電保護)
- 2 x USB 3.1 Gen1 連接埠 (支援靜電保護)
- 1 x RJ-45 LAN 連接埠，含 LED (ACT/LINK LED 及 SPEED LED)
- HD 音訊插孔：線路輸入／前置喇叭／麥克風

儲存裝置

- 4 x SATA3 6.0 Gb/s 接頭，支援 NCQ、AHCI 及「熱插拔」

接頭

- 1 x TPM 排針
- 1 x 機殼防護排針
- 1 x CPU 風扇接頭 (4-pin)
- * CPU 風扇接頭支援最高 1A (12W) 風扇功率的 CPU 風扇。
- 1 x 機殼／水冷幫浦風扇接頭 (4-pin) (智慧型風扇速度控制)
- * 機殼水冷幫浦風扇接頭支援最高 2A (24W) 風扇功率的水冷風扇。
- * 如果 3-pin 或 4-pin 風扇使用中，可自動偵測 CHA_FAN1/WP。
- 1 x 24 pin ATX 電源接頭
- 1 x 8 pin 12V 電源接頭
- 1 x 前面板音訊接頭
- 1 x USB 2.0 排針 (支援 2 個 USB 2.0 連接埠) (支援靜電保護)
- 1 x USB 3.1 Gen1 排針 (支援 2 個 USB 3.1 Gen1 連接埠) (支援靜電保護)

BIOS 功能

- AMI UEFI Legal BIOS 含多語 GUI 支援
- ACPI 6.0 符合喚醒自動開機
- 支援 SMBIOS 2.7
- DRAM、PCH 1.05V 電壓多重調整

硬體監視器

- 溫度感應：CPU、機殼／水冷幫浦風扇
- 風扇轉速計：CPU、機殼／水冷幫浦風扇
- 靜音風扇（依 CPU 溫度自動調整機殼風扇速度）：
CPU、機殼／水冷幫浦風扇
- 風扇多重速度控制：CPU、機殼／水冷幫浦風扇
- 機殼開啟偵測
- 電壓監控：+12V、+5V、+3.3V、CPU Vcore

作業系統

- Microsoft® Windows® 10 64-bit

認證

- FCC、CE
- ErP/EuP ready（須具備 ErP/EuP ready 電源供應器）

Spesifikasi

Platform

- Bentuk dan Ukuran Micro ATX
- Desain Kapasitor Solid

CPU

- Mendukung Prosesor Generasi ke-8 Intel® Core™ (Soket 1151)
- Desain 5 Fase Daya
- Mendukung Teknologi Intel® Turbo Boost 2.0

Chipset

- Intel® H310

Memori

- Teknologi Memori DDR4 Dua Saluran
- 2 x Slot DIMM DDR4
- Mendukung DDR4 2666/2400/2133 non-ECC, memori tanpa buffer
- Kapasitas maksimum memori sistem: 32GB
- Mendukung Intel® Extreme Memory Profile (XMP) 2.0
- 15µ Bidang Kontak Berwarna Emas di Slot DIMM

Slot

Ekspansi

- 1 x Slot PCI Express 3.0 x16 (PCIe2:x16 mode)*
- * Mendukung SSD NVMe sebagai disk boot
- 1 x Slot PCI Express 2.0 x1

Grafis

- Intel® UHD Graphics Built-in Visuals dan output VGA hanya didukung dengan prosesor yang terintegrasi GPU.
- Mendukung Intel® UHD Graphics Built-in Visuals: Intel® Quick Sync Video dengan AVC, MVC (S3D) dan MPEG-2 Full HW Encode1, Intel® InTru™ 3D, Intel® Clear Video HD Technology, Intel® Insider™, Intel® UHD Graphics
- DirectX 12
- Encode/Decode HWA: AVC/H.264, HEVC/H.265 8-bit, HEVC/H.265 10-bit, VP8, VP9 8-bit, VP9 10-bit (hanya Decode), MPEG2, MJPEG, VC-1 (hanya Decode)
- Mendukung DVI-D dengan resolusi maksimum hingga 1920x1200 @ 60Hz

- Mendukung HDCP dengan port DVI-D

Audio

- Audio HD 7.1 CH (Realtek ALC887 Audio Codec)
- * Untuk mengkonfigurasi Audio HD 7.1 CH, modul audio panel depan HD harus digunakan dan fitur audio multisaluran harus diaktifkan melalui driver audio.
- Mendukung Perlindungan dari Lonjakan Arus
- ELNA Audio Caps

LAN

- 1 x PCIE Gigabit LAN 10/100/1000 Mb/s
- 1 x Realtek RTL8111H
- Mendukung Wake-On-LAN
- Mendukung Perlindungan dari Petir/ESD
- Mendukung Ethernet Hemat Energi 802.3az
- Mendukung PXE

I/O Panel Belakang

- 1 x Port Mouse/Keyboard PS/2
- 1 x Port DVI-D
- 4 x Port USB 2.0 (Mendukung Perlindungan dari ESD)
- 2 x Port USB 3.1 Gen1 (Mendukung Perlindungan dari ESD)
- 1 x Port LAN RJ-45 dengan LED (LED ACT/LINK dan LED SPEED)
- Soket Audio HD: Saluran Masuk/Speaker Depan/Mikrofon

Penyimpanan

- 4 x Konektor SATA3 6,0 Gb/s, mendukung NCQ, AHCI, dan Hot Plug

Konektor

- 1 x Header TPM
- 1 x Intrusi Chassis dan Header Speaker
- 1 x Konektor Kipas CPU (4-pin)
- * Konektor Kipas CPU mendukung kipas CPU dengan daya kipas maksimum 1A (12W).
- 1 x Konektor Kipas Chassis/Pompa Air (4-pin) (Kontrol Kecepatan Kipas Pintar)

* Sasis Opsional/Kipas Pompa Air mendukung kipas berpendingin air dengan daya kipas maksimum 1,5A (18W).

* CHA_FAN1/WP dapat mendeteksi otomatis jika kipas 3-pin atau 4-pin sedang digunakan.

- 1 x Konektor Daya ATX 24 pin
- 1 x Konektor Daya 8 pin 12V
- 1 x Konektor Audio Panel Depan
- 1 x Header USB 2.0 (Mendukung 2 port USB 2.0) (Mendukung Perlindungan dari ESD)
- 1 x Header USB 3.1 Gen1 (Mendukung 2 port USB 3.1 Gen1) (Mendukung Perlindungan dari ESD)

Fitur BIOS

- AMI UEFI Legal BIOS dengan dukungan GUI multibahasa
- ACPI 6.0 Kompatibel dengan aktivitas pengaktifan
- Dukungan SMBIOS 2.7
- Multipengatur Tegangan DRAM, PCH 1,05V

Monitor Perangkat Keras

- Deteksi Suhu: Kipas CPU, Sasis, Pompa Air
- Takometer Kipas: Kipas CPU, Sasis, Pompa Air
- Kipas Hening (Penyesuaian otomatis kecepatan kipas sasis berdasarkan suhu CPU): Kipas CPU, Sasis, Pompa Air
- Kontrol Multikecepatan Kipas: Kipas CPU, Sasis, Pompa Air
- Deteksi CASE OPEN
- Pemantauan voltase: +12V, +5V, +3,3V, CPU Vcore

OS

- Microsoft® Windows® 10 64-bit

Sertifikasi

- FCC, CE
- Mendukung ErP/EuP (Memerlukan catu daya untuk ErP/EuP)

Specyfikacje

Platforma

- Współczynnik kształtu Micro ATX
- Konstrukcja kondensatorami stałymi

CPU

- Obsługa 8^{-ej} generacji procesorów Intel® Core™ (Socket 1151)
- Sekcja zasilania 5 Power Phase Design
- Obsługa technologii Intel® Turbo Boost 2.0

Chipset

- Intel® H310

Pamięć

- Technologia pamięci Dual Channel DDR4
- 2 x gniazda DDR4 DIMM
- Obsługa pamięci DDR4 2666/2400/2133 non-ECC, pamięć niebuforowana
- Maks. wielkość pamięci systemowej: 32GB
- Obsługa Intel® Extreme Memory Profile (XMP) 2.0
- 15μ pozłacane styki w gniazdach DIMM

Gniazdo rozszerzenia

- 1 x gniazdo PCI Express 3.0 x16 (tryb PCIE2:x16)*
- * Obsługa SSD NVMe, jako dysków rozruchowych
- 1 x gniazdo PCI Express 2.0 x1

Grafika

- Wbudowana grafika Intel® UHD i wyjścia VGA są obsługiwane wyłącznie z procesorami, które mają zintegrowane GPU.
- Obsługa wbudowanej grafiki Intel® UHD: Intel® Quick Sync Video z AVC, MVC (S3D) i MPEG-2 Full HW Encode1, Intel® InTru™ 3D, Intel® Clear Video HD Technology, Intel® Insider™, grafika Intel® UHD
- DirectX 12
- Kodowanie/dekodowanie HWA: AVC/H.264, HEVC/H.265 8-bit, HEVC/H.265 10-bit, VP8, VP9 8-bit, VP9 10-bit (tylko dekodowanie), MPEG2, MJPEG, VC-1 (tylko dekodowanie)
- Obsługa DVI-D z maks. rozdzielczością do 1920x1200 przy 60Hz

- Obsługa HDCP z portem DVI-D

Audio

- Dźwięk HD 7.1 CH (kodek audio Realtek ALC887)
- * Aby skonfigurować dźwięk 7.1 CH HD wymagane jest użycie modułu panelu czołowego HD i włączenie funkcji dźwięku wielokanałowego za pośrednictwem sterownika audio.
- Obsługa zabezpieczenia przed przepięciami
- Nasadki audio ELNA

LAN

- 1 x PCIE Gigabit LAN 10/100/1000 Mb/s
- 1 x Realtek RTL8111H
- Obsługa Wake-On-LAN
- Obsługa zabezpieczenia przed wyładowaniami atmosferycznymi/ESD
- Obsługa Energy Efficient Ethernet 802.3az
- Obsługa PXE

Tyłny panel Wejścia/ Wyjścia

- 1 x port myszy/klawiatury PS/2
- 1 x port DVI-D
- 4 x porty USB 2.0 (Obsługa zabezpieczenia ESD)
- 2 x porty USB 3.1 Gen1 (Obsługa zabezpieczenia ESD)
- 1 x porty LAN RJ-45 z LED (LED ACT/LINK i LED SPEED)
- Gniazda audio HD: Wejście liniowe / Głośnik przedni / Mikrofon

Przechowywanie

- 4 x złącza SATA3 6,0 Gb/s, obsługa NCQ, AHCI i Hot Plug

Złącze

- 1 x złącze główkowe TPM
- 1 x złącze główkowe naruszenia obudowy i głośnika
- 1 x złącze wentylatora CPU (4-pinowe)
- * Złącze wentylatora CPU obsługuje wentylator CPU maksymalnym prądem zasilania wentylatora 1A (12W).
- 1 x złącza wentylatora obudowy/pompy wodnej (4-pinowe) (Inteligentne sterowanie prędkością obrotową wentylatora)
- * Złącze wentylatora obudowy/pompy wodnej obsługuje wentylator układu chłodzenia maksymalnym prądem zasilania wentylatora 2A (24W).
- * CHA_FAN1/WP może automatycznie wykrywać, jeśli używany jest wentylator 3-pinowy lub 4-pinowy.

- 1 x 24 pinowe złącze zasilania ATX
- 1 x 8 pinowe złącze zasilania 12 V
- 1 x złącze audio na panelu przednim
- 1 x złącza główkowe USB 2.0 (obsługuje 2 porty USB 2.0)
(Obsługa zabezpieczenia ESD)
- 1 x porty główkowe USB 3.1 Gen1 (obsługa 2 portów USB 3.1 Gen1) (obsługa zabezpieczenia ESD)

Funkcja BIOS

- Obsługa starszych wersji BIOS AMI UEFI z wielojęzycznym GUI
- Zgodność zdarzeń wybudzania z ACPI 6.0
- Obsługa SMBIOS 2.7
- Wiele regulacji napięcia DRAM, PCH 1,05V

Monitor sprzętu

- Wykrywanie temperatury: CPU, wentylatory obudowy/pompy wodnej
- Obrotomierz wentylatora: CPU, wentylatory obudowy/pompy wodnej
- Cichy wentylator (Automatyczna regulacja prędkości obrotowej wentylatora obudowy przez temperaturę CPU): CPU, wentylatory obudowy/pompy wodnej
- Kontrola wielu prędkości obrotowych wentylatora: CPU, wentylatory obudowy/pompy wodnej
- Wykrywanie OTWARCIA OBUDOWY
- Monitorowanie napięcia: +12 V, +5 V, +3,3 V, napięcie rdzenia CPU (Vcore)

System operacyjny

- Microsoft® Windows® 10 64-bitowy

Certyfikaty

- FCC, CE
- Gotowość do obsługi ErP/EuP (Wymagane zasilanie z gotowością obsługi ErP/EuP)

* Dla uzyskania szczegółowej informacji o produkcie, należy odwiedzić naszą stronę internetową:
<http://www.asrock.com>

Contact Information

If you need to contact ASRock or want to know more about ASRock, you're welcome to visit ASRock's website at <http://www.asrock.com>; or you may contact your dealer for further information. For technical questions, please submit a support request form at <https://event.asrock.com/tsd.asp>

ASRock Incorporation

2F., No.37, Sec. 2, Jhongyang S. Rd., Beitou District,

Taipei City 112, Taiwan (R.O.C.)

ASRock EUROPE B.V.

Bijsterhuizen 11-11

6546 AR Nijmegen

The Netherlands

Phone: +31-24-345-44-33

Fax: +31-24-345-44-38

ASRock America, Inc.

13848 Magnolia Ave, Chino, CA91710

U.S.A.

Phone: +1-909-590-8308

Fax: +1-909-590-1026

DECLARATION OF CONFORMITY

Per FCC Part 2 Section 2.1077(a)



Responsible Party Name: ASRock Incorporation

Address: 13848 Magnolia Ave, Chino, CA91710

Phone/Fax No: +1-909-590-8308/+1-909-590-1026

hereby declares that the product

Product Name : Motherboard

Model Number : H310M-DGS

Conforms to the following specifications:

FCC Part 15, Subpart B, Unintentional Radiators

Supplementary Information:

This device complies with part 15 of the FCC Rules. Operation is subject to the following two conditions: (1) This device may not cause harmful interference, and (2) this device must accept any interference received, including interference that may cause undesired operation.

Representative Person's Name: James

Signature:

A handwritten signature in black ink, appearing to read 'James', written over a horizontal line.

Date : May 12, 2017

EU Declaration of Conformity

ASRock®

For the following equipment:

Motherboard

(Product Name)

H310M-DGS / ASRock

(Model Designation / Trade Name)

ASRock Incorporation

(Manufacturer Name)

2F, No.37, Sec. 2, Jhongyang S. Rd., Beitou District, Taipei City 112, Taiwan (R.O.C.)

(Manufacturer Address)

EMC — Directive 2014/30/EU (from April 20th, 2016)

EN 55022:2010/AC:2011 Class B

EN 55024:2010/A1:2015

EN 55032:2012+AC:2013 Class B

EN 61000-3-3:2013

EN 61000-3-2:2014

LVD — Directive 2014/35/EU (from April 20th, 2016)

EN 60950-1 : 2011+ A2: 2013

EN 60950-1 : 2006/A12: 2011

RoHS — Directive 2011/65/EU

CE marking

(EU conformity marking)



ASRock EUROPE B.V.

(Company Name)

Bijsterhuizen 1111 6546 AR Nijmegen The Netherlands

(Company Address)

Person responsible for making this declaration:

(Name, Surname)

A.V.P

(Position / Title)

March 9, 2018

(Date)

P/N: 15G062073000AK V1.0