



OPEN Industry Standard, Flexible Architecture

GREEN Less Heat, Less Power Consumption

STABLE Robust Design, Quality Parts

Stable and
Reliable Solution

Server/Workstation
Motherboard

EPYC4000D4U

User Manual

English



Version 1.20

Published Jun. 2026

Copyright©2026 ASRock Rack INC. All rights reserved.

Copyright Notice:

No part of this documentation may be reproduced, transcribed, transmitted, or translated in any language, in any form or by any means, except duplication of documentation by the purchaser for backup purpose, without written consent of ASRock Rack Inc.

Products and corporate names appearing in this documentation may or may not be registered trademarks or copyrights of their respective companies, and are used only for identification or explanation and to the owners' benefit, without intent to infringe.

Disclaimer:

Specifications and information contained in this documentation are furnished for informational use only and subject to change without notice, and should not be construed as a commitment by ASRock Rack. ASRock Rack assumes no responsibility for any errors or omissions that may appear in this documentation.

With respect to the contents of this documentation, ASRock Rack does not provide warranty of any kind, either expressed or implied, including but not limited to the implied warranties or conditions of merchantability or fitness for a particular purpose.

In no event shall ASRock Rack, its directors, officers, employees, or agents be liable for any indirect, special, incidental, or consequential damages (including damages for loss of profits, loss of business, loss of data, interruption of business and the like), even if ASRock Rack has been advised of the possibility of such damages arising from any defect or error in the documentation or product.

CALIFORNIA, USA ONLY

The Lithium battery adopted on this motherboard contains Perchlorate, a toxic substance controlled in Perchlorate Best Management Practices (BMP) regulations passed by the California Legislature. When you discard the Lithium battery in California, USA, please follow the related regulations in advance. "Perchlorate Material-special handling may apply, see www.dtsc.ca.gov/hazardouswaste/perchlorate"

AUSTRALIA ONLY

Our goods come with guarantees that cannot be excluded under the Australian Consumer Law. You are entitled to a replacement or refund for a major failure and compensation for any other reasonably foreseeable loss or damage caused by our goods. You are also entitled to have the goods repaired or replaced if the goods fail to be of acceptable quality and the failure does not amount to a major failure. If you require assistance please call ASRock Rack Tel : +886-2-55599600 ext.123 (Standard International call charges apply)



The terms HDMI® and HDMI High-Definition Multimedia Interface, and the HDMI logo are trademarks or registered trademarks of HDMI Licensing LLC in the United States and other countries.

ASRock Rack's Website: www.ASRockRack.com



This device complies with Part 15 of the FCC Rules. Operation is subject to the following two conditions:

- (1) this device may not cause harmful interference, and
- (2) this device must accept any interference received, including interference that may cause undesired operation.

This equipment has been tested and found to comply with the limits for a Class B digital device, pursuant to part 15 of the FCC Rules. These limits are designed to provide reasonable protection against harmful interference in a residential installation. This equipment generates, uses and can radiate radio frequency energy and, if not installed and used in accordance with the instructions, may cause harmful interference to radio communications.

However, there is no guarantee that interference will not occur in a particular installation. If this equipment does cause harmful interference to radio or television reception, which can be determined by turning the equipment off and on, the user is encouraged to try to correct the interference by one or more of the following measures:

- Reorient or relocate the receiving antenna.
- Increase the separation between the equipment and receiver.
- Connect the equipment into an outlet on a circuit different from that to which the receiver is connected.
- Consult the dealer or an experienced radio/TV technician for help.



ASRock Rack INC. hereby declares that this device is in compliance with the essential requirements and other relevant provisions of related UKCA Directives. Full text of UKCA declaration of conformity is available at: <http://www.asrockrack.com>



ASRock Rack INC. hereby declares that this device is in compliance with the essential requirements and other relevant provisions of related Directives. Full text of EU declaration of conformity is available at: <http://www.asrockrack.com>

ASRock Rack follows the green design concept to design and manufacture our products, and makes sure that each stage of the product life cycle of ASRock Rack product is in line with global environmental regulations. In addition, ASRock Rack disclose the relevant information based on regulation requirements.

Please refer to <https://www.asrockrack.com/general/about.asp?cat=Responsibility> for information disclosure based on regulation requirements ASRock Rack is complied with.



DO NOT throw the motherboard in municipal waste. This product has been designed to enable proper reuse of parts and recycling. This symbol of the crossed out wheeled bin indicates that the product (electrical and electronic equipment) should not be placed in municipal waste. Check local regulations for disposal of electronic products.

Contents

Chapter 1 Introduction	1
1.1 Package Contents	1
1.2 Specifications	2
1.3 Unique Features	5
1.4 Motherboard Layout	6
1.5 Onboard LED Indicators	8
1.6 I/O Panel	10
1.7 Block Diagram	12
Chapter 2 Installation	13
2.1 Screw Holes	13
2.2 Pre-installation Precautions	13
2.3 Installing the CPU	14
2.4 Installing the CPU Fan and Heatsink	17
2.5 Installing Memory Modules (DIMM)	19
2.6 Expansion Slot (PCI Express Slot)	21
2.7 Jumper Setup	22
2.8 Onboard Headers and Connectors	23
2.9 Dr. Debug	30
2.10 Unit Identification purpose LED/Switch	36
2.11 M.2 SSD Module Installation Guide	37
Chapter 3 UEFI Setup Utility	39
3.1 Introduction	39
3.1.1 UEFI Menu Bar	39

3.1.2	Navigation Keys	40
3.2	Main Screen	41
3.3	Advanced Screen	44
3.3.1	CPU Configuration	45
3.3.2	Chipset Configuration	46
3.3.3	Storage Configuration	48
3.3.4	NVMe Configuration	49
3.3.5	ACPI Configuration	50
3.3.6	USB Configuration	51
3.3.7	Super IO Configuration	52
3.3.8	Serial Port Console Redirection	53
3.3.9	H/W Monitor	56
3.3.10	PCI Subsystem Settings	57
3.3.11	AMD CBS	58
3.3.12	Trusted Computing	65
3.3.13	Network Stack Configuration	67
3.3.14	Driver Health	68
3.3.15	Tls Auth Configuration	69
3.3.16	AMD PBS	70
3.3.17	AMD Overclocking	73
3.3.18	Inter(R) Ethernet Controller I210-LM	74
3.3.19	VLAN Configuration	75
3.3.20	Instant Flash	76
3.4	Security	77

3.4.1	Install Default Secure Boot Keys	79
3.4.2	Expert Key Management	80
3.5	Server Mgmt	84
3.5.1	BMC Network Configuration	86
3.5.2	DNS Configuration	88
3.5.3	System Event Log	90
3.5.4	BMC Tools	91
3.6	Boot Screen	92
3.6.1	CSM Parameters	93
3.7	Exit Screen	94
	Chapter 4 Software Support	95
4.1	Download and Install Operating System	95
4.2	Download and Install Software Drivers	95
4.3	Contact Information	95
	Chapter 5 Troubleshooting	96
5.1	Troubleshooting Procedures	96
5.2	Technical Support Procedures	98
5.3	Returning Merchandise for Service	98
	Contact Information	99

Chapter 1 Introduction

Thank you for purchasing ASRock Rack **EPYC4000D4U** motherboard, a reliable motherboard produced under ASRock Rack's consistently stringent quality control. It delivers excellent performance with robust design conforming to ASRock Rack's commitment to quality and endurance.

In this manual, chapter 1 and 2 contains introduction of the motherboard and step-by-step guide to the hardware installation. Chapter 3 and 4 contains the configuration guide to BIOS setup and information of the Support Software.



Because the motherboard specifications and the BIOS software might be updated, the content of this manual will be subject to change without notice. In case any modifications of this manual occur, the updated version will be available on ASRock Rack website without further notice. Find the latest memory and CPU support lists on ASRock Rack website as well. ASRock Rack's Website: www.ASRockRack.com

*Please visit the website for specific information and technical support:
<http://www.asrockrack.com/support/>*

1.1 Package Contents

- ASRock Rack EPYC4000D4U motherboard
(micro ATX form factor: 9.6" x 9.6", 244 mm x 244 mm)
- Quick installation guide
- 1 I/O shield
- 1 SATA3 cable (60 cm)
- 2 Screws for M.2 sockets
- 1 SATA power 4pin to 15pin



If any items are missing or appear damaged, contact the authorized dealer.

1.2 Specifications

EPYC4000D4U	
Physical Status	
Form Factor	Micro-ATX
Dimension	9.6" x 9.6" (244 mm x 244 mm)
Processor System	
CPU	Supports AMD EPYC 4005/4004 and AMD Ryzen 9000/8000/7000 series Processors
Socket	1 Socket AM5 (LGA1718)
Thermal Design Power (TDP)	Up to 170W by proper cooling solution
Chipset	KNOLL3 X600
System Memory	
Supported DIMM Quantity	4 DIMM slots (2DPC)
Supported Type	DDR5 288-pin ECC/non-ECC UDIMM
Max. Capacity per DIMM	48GB
Max. DIMM Frequency	5600 MHz (1DPC); 3600 MHz (2DPC)
Voltage	1.1V
<i>Note: Memory support is to be validated.</i>	
PCIe Expansion Slot	
PCIe x16	<p>SLOT6: PCIe 5.0 x16 [CPU]*</p> <p><i>*When installing AMD Ryzen™ 8000 Series (Phoenix) Processors, SLOT6 will support only PCIe4.0 x8</i></p> <p><i>*When installing AMD Ryzen™ 8000 Series (Phoenix2) Processors, SLOT6 will support only PCIe4.0 x4</i></p>
Other PCIe Expansion Connectors	
M.2	<p>2 M-key (PCIe 5.0 x4), supports 2280/2242 form factor [CPU]*</p> <p><i>*When installing AMD Ryzen™ 8000 Series (Phoenix) Processors, 2 M.2 will support only PCIe4.0 x4</i></p> <p><i>*When installing AMD Ryzen™ 8000 Series (Phoenix2) Processors, M2_1 will support only PCIe4.0 x2 and M2_2 will support only PCIe4.0 x4</i></p>
MCIO	<p>MCIO1 (PCIe 5.0 x8)*</p> <p>MCIO2 (2 PCIe 5.0 x4)*</p> <p><i>*MCIO1 shares lanes with SLOT6.</i></p> <p><i>1. MCIO1 will be disabled when SLOT6 is occupied by PCIe x16 device</i></p> <p><i>2. MCIO1 will be fully functional when SLOT6 is occupied by PCIe x8 device or unoccupied</i></p> <p><i>*MCIO2 shares lanes with 2 M.2:</i></p> <p><i>1. MCIO2 will be disabled when both M.2 are populated</i></p> <p><i>2. MCIO2 will support PCIe x4 when 1 M.2 is populated</i></p> <p><i>*When installing AMD Ryzen™ 8000 Series (Phoenix) Processors, MCIO1 will be disabled and MCIO2 will support only 2 PCIe4.0 x4</i></p> <p><i>*When installing AMD Ryzen™ 8000 Series (Phoenix2) Processors, MCIO1 will be disabled and MCIO2 will support only 1 PCIe4.0 x4 and 1 PCIe4.0 x2</i></p>

SATA/SAS Storage	
PCH Built-in Storage	ASMedia 1061 (2 SATA 6 Gb/s): 2 SATA 7-pin
Ethernet	
Additional GbE Controller	Intel® i210: 2 RJ45 (1 GbE)
Server Management	
BMC Controller	ASPEED AST2600: IPMI 2.0 with iKVM and vMedia support
Dedicated IPMI LAN	1 Realtek RTL8211F for dedicated management LAN
Graphics	
Controller	ASPEED AST2600: 1 DB15 (VGA) AMD Processors with Graphics: 1 HDMI, 1 DisplayPort
Rear I/O	
UID Button/LED	1 UID button w/ LED
Video Output	1 DB15 (VGA), 1 HDMI, 1 DisplayPort
Serial Port	1 DB9 (COM)
USB Port	2 Type-A (USB 3.2 Gen1)
LAN Port	2 RJ45 (1 GbE), 1 dedicated IPMI
Internal Connectors/Headers	
Power Connector	1 (24-pin, ATX main power), 2 (8-pin, ATX 12V) support 12V DC-in
Other Power Connectors	1 (4-pin) for HDD power
Auxiliary Panel Header	1 (18-pin): chassis intrusion, system fault LED, LAN activity LED
System Panel Header	1 (9-pin): power switch, reset switch, system power LED, HDD activity LED
Speaker Header	1
Fan Header	7 (6pin)
TPM Header	1 (13-pin, SPI)
SMBus Header	1
PMbus Header	1
IPMB Header	1
USB Header	1 (19-pin, 1 USB 3.2 Gen1 and 2 USB 2.0)
Clear CMOS	1
Others	1 SD Card, 1 Buzzer, 1 header (3-pin, 80 debug port)
LED Indicators	
Standby Power LED	1 (5VSB)
80 Debug Port LED	1
Fan Fail LED	7
BMC Heartbeat LED	1

Support OS

OS	<p>AMD Ryzen CPUs:</p> <p>Microsoft® Windows:</p> <ul style="list-style-type: none"> - Windows® 10 (64 bit) - Windows® 11 (64 bit) <p>Linux:</p> <ul style="list-style-type: none"> - Red Hat Enterprise Linux Server 8.7 (64 bit) - SUSE SLES 15.2 (64 bit) / 15.4 (64 bit) - Ubuntu 21.04 (64 bit) / 21.10 (64 bit) / 22.04.1 (64 bit) <p>Hypervisor:</p> <ul style="list-style-type: none"> - VMWare® ESXi 7.0 U3g / 8.0 <p>AMD EPYC 4004 CPUs:</p> <p>Microsoft® Windows:</p> <ul style="list-style-type: none"> - Windows® Server2022 (64 bit) <p><i>* Note: Please change the BIOS setting: Advanced > Chipset Configuration > Server WHQL Support [Enabled]. Set this option to [Enabled] to ensure the best compatibility with Windows Server environments.</i></p> <p>Linux:</p> <ul style="list-style-type: none"> - Red Hat Enterprise Linux Server 9.3 (64 bit) / 9.4 (64 bit) - SUSE SLES 15.5 (64 bit) - Ubuntu 20.04.6 (64 bit) / 22.04.4 (64 bit) <p>Hypervisor:</p> <ul style="list-style-type: none"> - VMWare® ESXi 7.0 U3g / 8.0U2b <p>AMD EPYC 4005 CPUs:</p> <p>Microsoft® Windows:</p> <ul style="list-style-type: none"> - Windows® Server2022 (64 bit) - Windows® Server2025 (64 bit) <p><i>* Note: Please change the BIOS setting: Advanced > Chipset Configuration > Server WHQL Support [Enabled]. Set this option to [Enabled] to ensure the best compatibility with Windows Server environments.</i></p> <p>Linux:</p> <ul style="list-style-type: none"> - Red Hat Enterprise Linux Server 9.4 (64 bit) / 10.0 (64 bit) - SUSE SLES 15.6 (64 bit) - Ubuntu 22.04.5 (64 bit) / 24.04.2 (64 bit) <p><i>* Supports UEFI BOOT only</i></p> <p><i>* The Linux system doesn't support RAID Mode</i></p>
----	--

Environment

Temperature	<p>Operating temperature: 10°C ~ 35°C</p> <p>Non operating temperature: -40°C ~ 70°C</p>
Humidity	Non operating humidity: 20% ~ 90% (non-condensing)

NOTE: Please refer to the website for the latest specifications.



This motherboard supports Wake from on Board LAN. To use this function, please make sure that the "Wake on Magic Packet from power off state" is enabled in Device Manager > Intel® Ethernet Connection > Power Management. And the "PCI Devices Power On" is enabled in UEFI SETUP UTILITY > Advanced > ACPI Configuration. After that, onboard LAN1&2 can wake up S5 under OS.



If installing Intel® LAN utility or Marvell SATA utility, this motherboard may fail Windows® Hardware Quality Lab (WHQL) certification tests. If installing the drivers only, it will pass the WHQL tests.

1.3 Unique Features

ASRock Rack Instant Flash is a BIOS flash utility embedded in Flash ROM. This convenient BIOS update tool allows user to update system BIOS without entering operating systems first like MS-DOS or Windows. With this utility, press the <F6> key during the POST or the <F2> key to enter into the BIOS setup menu to access ASRock Rack Instant Flash. Just launch this tool and save the new BIOS file to the USB flash drive, floppy disk or hard drive, then update the BIOS only in a few clicks without preparing an additional floppy diskette or other complicated flash utility. Please be noted that the USB flash drive or hard drive must use FAT32/16/12 file system.

No.	Description
1	2 x 288-pin DDR5 DIMM Slots (DDR5_A2, DDR5_B2)*
2	SATA Power Connector (SATA_PWR1)
3	2 x 288-pin DDR5 DIMM Slots (DDR5_A1, DDR5_B1)*
4	ATX 12V Power Connector (ATX12V1)
5	ATX 12V Power Connector (ATX12V2)
6	PSU SMBus Header (PSU_SMB1)
7	Clear CMOS Pad (CLRCMOS1)
8	ATX Power Connector (ATXPWR1)
9	System Fan Connector (FAN1)
10	System Fan Connector (FAN7)
11	System Fan Connector (FAN6)
12	AMD Socket AM5 (LGA 1718)
13	SPI TPM Header (TPM_BIOS_PH1)
14	PWM Configuration Header (PWM_CFG1)
15	Mini Cool Edge IO Connector (MCIO2)
16	Mini Cool Edge IO Connector (MCIO1)
17	Speaker Header (SPEAKER1)
18	System Fan Connector (FAN4)
19	System Fan Connector (FAN2)
20	System Fan Connector (FAN3)
21	Auxiliary Panel Header (AUX_PANEL1)
22	System Fan Connector (FAN5)
23	System Panel Header (PANEL1)
24	USB 3.2 Gen1 Header (USB3_3_4)
25	M.2 Socket (M2_1) (Type 2242/2280)
26	M.2 Socket (M2_2) (Type 2242/2280)
27	PCI Express 5.0 x16 Card Slot (PCIE6)
28	Chassis ID Jumper (CHASSIS_ID0)
29	BMC SMBus Header (BMC_SMB1)
30	Intelligent Platform Management Bus Header (IPMB1)
31	SATA3 Connector (SATA3)
32	MicroSD Card Slot (SD_CARD1)
33	SATA3 Connector (SATA2)

*For DIMM installation and configuration instructions, please see p.19 (Installing Memory Modules (DIMM)) for more details.

1.5 Onboard LED Indicators

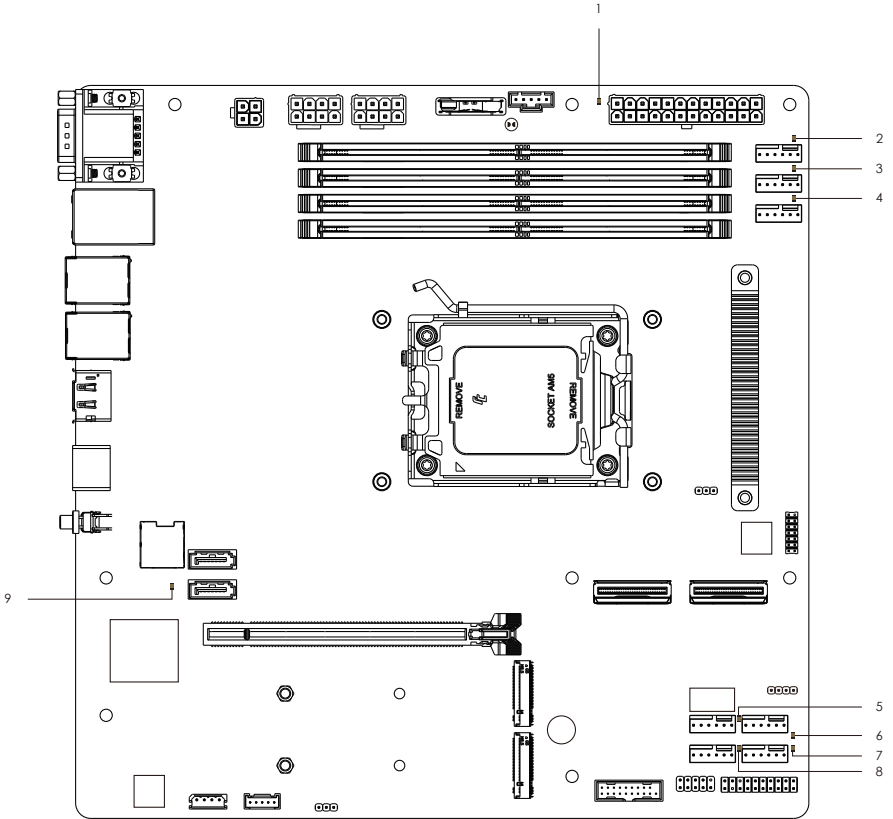

No.	Item	Status	Description
1	SB_PWR1	Green	STB PWR ready
2	FAN_LED1	Amber	FAN1 failed
3	FAN_LED7	Amber	FAN7 failed
4	FAN_LED6	Amber	FAN6 failed
5	FAN_LED2	Amber	FAN2 failed
6	FAN_LED4	Amber	FAN4 failed
7	FAN_LED3	Amber	FAN3 failed
8	FAN_LED5	Amber	FAN5 failed
9	BMC_LED1	Blinking four times and then off	Start initialization after AC power-on or BMC reset
		Blinking at 1Hz	BMC ready
		Steady on	Error
		Steady off	(The actual behavior depends on the state at the time of failure.)
		Other frequency	

1.6 I/O Panel

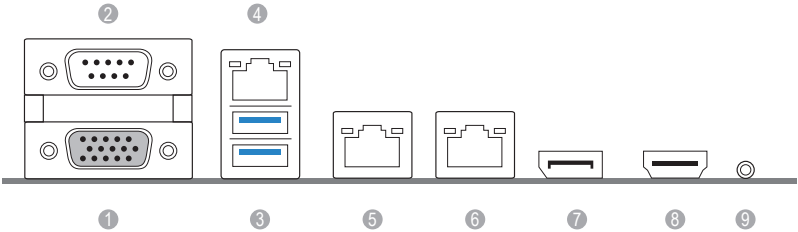

No.	Description	No.	Description
1	VGA Port (VGA)	6	1G LAN RJ-45 Port (LAN2)**
2	Serial Port (COM1)	7	DisplayPort (DP1)
3	USB 3.2 Gen1 Ports (USB3_1_2)	8	HDMI Port (HDMI1)
4	LAN RJ-45 Port (IPMI_LAN)*	9	UID Switch (UID1)
5	1G LAN RJ-45 Port (LAN1, shared NIC)**		

*There are two LEDs on the IPMI LAN port specified for link activity and speed. Please refer to the table below for the LAN port LED indications.

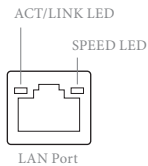

IPMI LAN Port LED Indications

Activity / Link LED		Speed LED	
Status	Description	Status	Description
Off	No link	Off	10 Mbps connection or no link
Blinking Yellow	Data activity	Yellow	100 Mbps connection
On	Link	Green	1 Gbps connection

**There are two LEDs on the 1G LAN port specified for link activity and speed. Please refer to the table below for the LAN port LED indications.

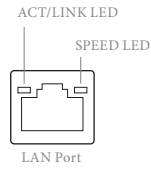

1G LAN Port (LAN1, LAN2) LED Indications

Activity / Link LED		Speed LED	
Status	Description	Status	Description
Off	No link	Off	10 Mbps connection or no link
Blinking Yellow	Data activity	Orange	100 Mbps connection
On	Link	Green	1 Gbps connection

1.7 Block Diagram

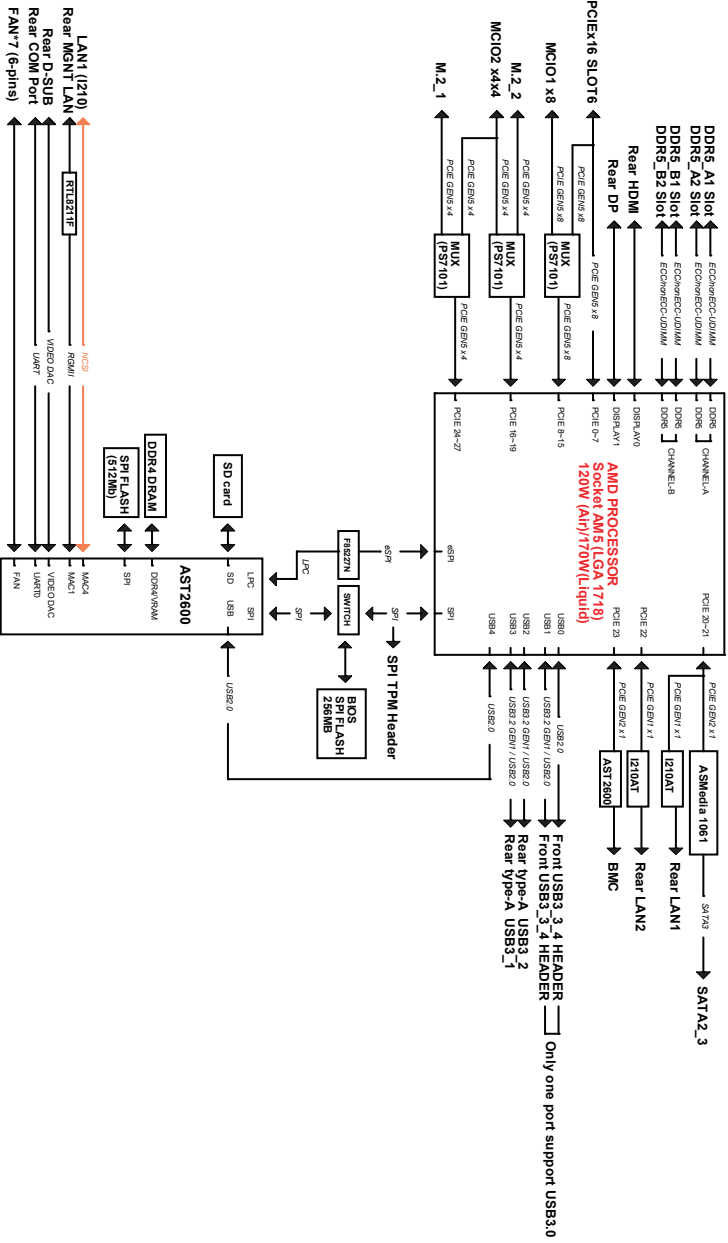

Chapter 2 Installation

This is a micro-ATX form factor (244 mm x 244 mm) motherboard. Before installing the motherboard, study the configuration of the chassis to ensure that the motherboard fits into it.



1. Ensure the motherboard battery is installed before unplugging the power cord or installing/removing the motherboard.
2. Before installing or removing any component, ensure that the power supply is off or the power cord is detached from the power supply. Failure to do so may cause severe damage to the motherboard, peripherals, and/or components.

2.1 Screw Holes

Place screws into the holes indicated by circles to secure the motherboard to the chassis.



Do not over-tighten the screws! Doing so may damage the motherboard.

2.2 Pre-installation Precautions

Take note of the following precautions before installing motherboard components or change any motherboard settings.

1. Unplug the power cord from the wall socket before touching any components.
2. To avoid damaging the motherboard's components due to static electricity, NEVER place the motherboard directly on the carpet or the like. Also remember to use a grounded wrist strap or touch a safety grounded object before handling the components.
3. Hold components by the edges and do not touch the ICs.
4. Whenever uninstall any component, place it on a grounded anti-static pad or in the bag that comes with the component.
5. When placing screws into the screw holes to secure the motherboard to the chassis, please do not over-tighten the screws! Doing so may damage the motherboard.

2.3 Installing the CPU



1. Before inserting the CPU into the socket, please check if the **PnP cap** is on the socket, if the CPU surface is unclean, or if there are any **bent pins** in the socket. Do not force to insert the CPU into the socket if above situation is found. Otherwise, the CPU will be seriously damaged.
2. Unplug all power cables before installing the CPU.

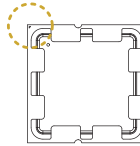
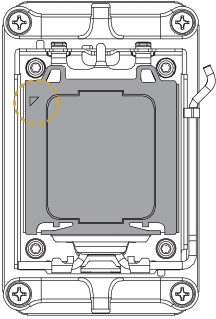

Turn the CPU to the correct orientation before opening the CPU socket cover.

1

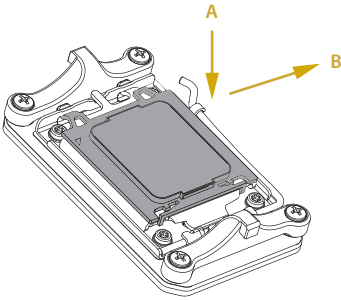

2

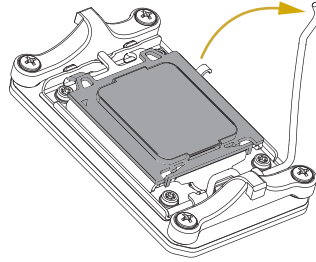

3

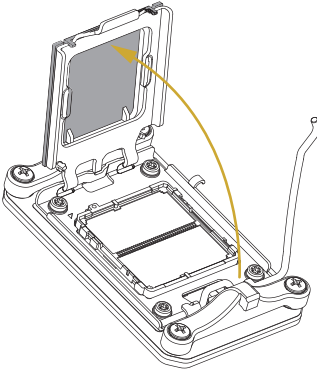

4

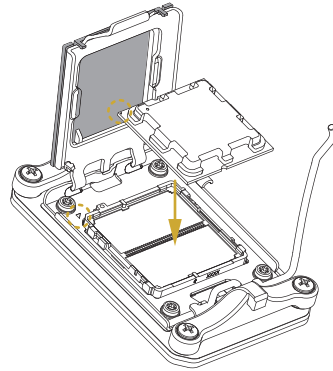

Carefully place the CPU in as flat as possible. Do not drop it.

5

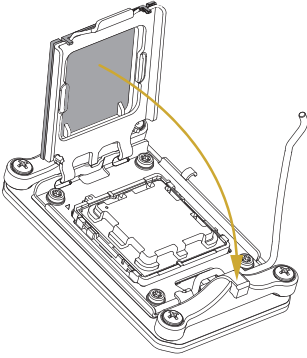

6

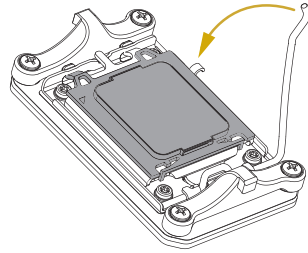

Make sure the CPU is aligned with the socket before locking it into place.

7

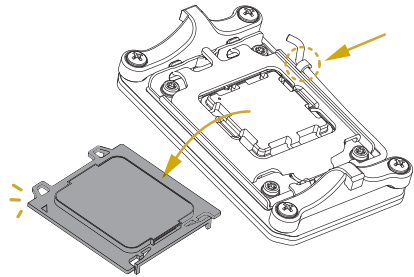

Make sure the black cover plate is always in place until it pops off when closing the socket lever.



Please save the cover if the processor is removed. The cover must be placed if wishing to return the motherboard for after service.

2.4 Installing the CPU Fan and Heatsink

After installing the CPU into this motherboard, it is necessary to install a larger heatsink and cooling fan to dissipate heat. It also needs to spray thermal grease between the CPU and the heatsink to improve heat dissipation. Make sure that the CPU and the heatsink are securely fastened and in good contact with each other.



Please turn off the power or remove the power cord before changing a CPU or heatsink.

Installing the CPU Cooler

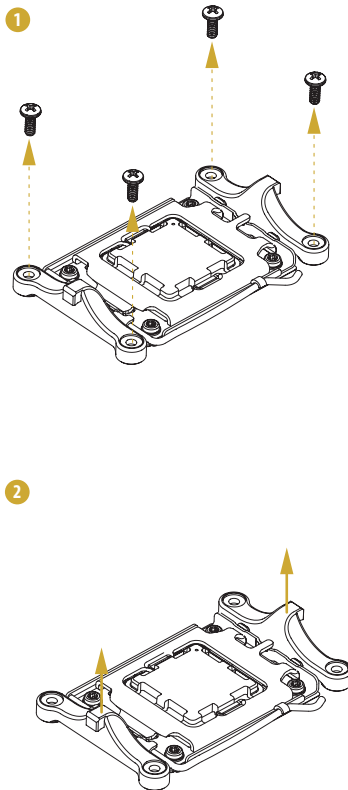

3

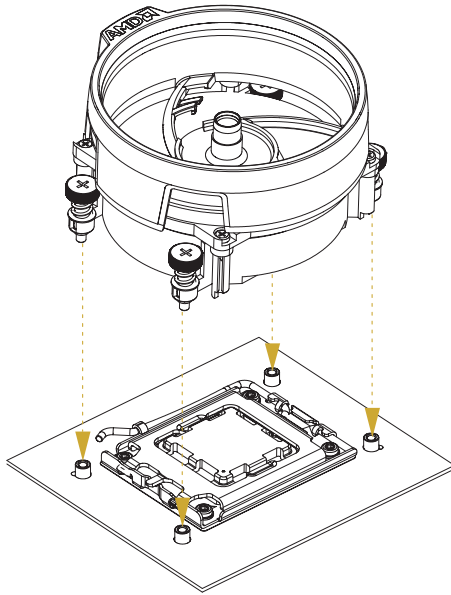

4

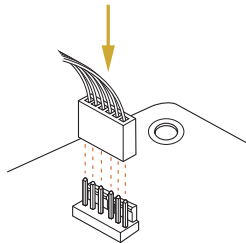

2.5 Installing Memory Modules (DIMM)

This motherboard provides four 288-pin DDR5 (Double Data Rate 5) DIMM slots, and supports Dual Channel Memory Technology.



1. For dual channel configuration, it always needs to install identical (the same brand, speed, size and chip-type) DDR5 DIMM pairs.
2. It is unable to activate Dual Channel Memory Technology with only one or three memory module installed.
3. It is not allowed to install a DDR, DDR2, DDR3 or DDR4 memory module into a DDR5 slot; otherwise, this motherboard and DIMM may be damaged.
4. The DIMM only fits in one correct orientation. It will cause permanent damage to the motherboard and the DIMM if forcing the DIMM into the slot at incorrect orientation.

Recommended Memory Configuration

	Priority	A1	A2	B1	B2
1 DIMM	1	V			
	2			V	
2 DIMMS	1	V		V	
	2	V	V		
	3			V	V
4 DIMMS	1	V	V	V	V

The Symbol V indicates the slot is populated.

1

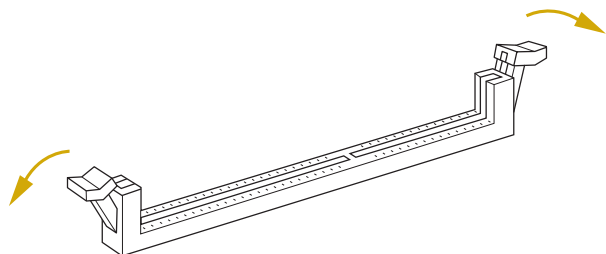

2

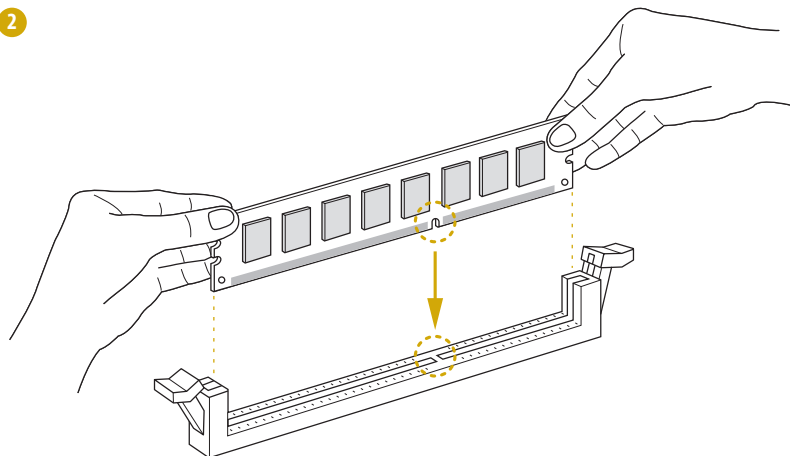

3

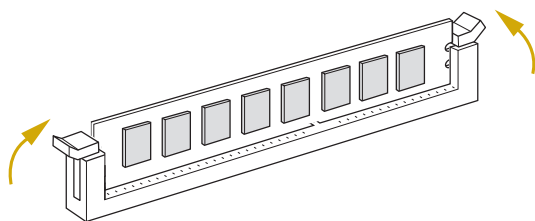

The DIMM only fits in one correct orientation. It will cause permanent damage to the motherboard and the DIMM if forcing the DIMM into the slot at incorrect orientation.

2.6 Expansion Slot (PCI Express Slot)

There is one PCI Express slot on this motherboard.

PCIe slot:

PCIe6 (PCIe 5.0 x16 slot, from CPU) is used for PCI Express x16 lane width cards.

Slot	Generation	Mechanical	Electrical	Source
PCIe6	5.0	x16	x16	CPU

** When installing AMD Ryzen™ 8000 Series (Phoenix) Processors, PCIe6 supports PCIe4.0 x8 only.*

** When installing AMD Ryzen™ 8000 Series (Phoenix 2) Processors, PCIe6 supports PCIe4.0 x4 only.*

** MCI01 will be disabled when SLOT6 is occupied by PCIe x16 device.*

** MCI01 will be fully functional when SLOT6 is occupied by PCIe x8 device or unoccupied*

Installing an expansion card

- Step 1. Before installing an expansion card, please make sure that the power supply is switched off or the power cord is unplugged. Please read the documentation of the expansion card and make necessary hardware settings for the card before starting the installation.
- Step 2. Remove the system unit cover (if the motherboard is already installed in a chassis).
- Step 3. Remove the bracket facing the slot that intending to use. Keep the screws for later use.
- Step 4. Align the card connector with the slot and press firmly until the card is completely seated on the slot.
- Step 5. Fasten the card to the chassis with screws.
- Step 6. Replace the system cover.

2.7 Jumper Setup

The illustration shows how jumpers are setup. When the jumper cap is placed on the pins, the jumper is “Short”. If no jumper cap is placed on the pins, the jumper is “Open”. The illustration shows a 3-pin jumper whose pin1 and pin2 are “Short” when a jumper cap is placed on these 2 pins.

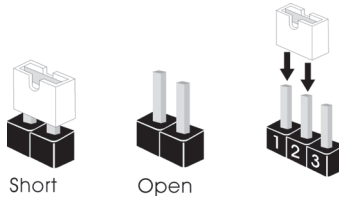

Chassis ID Jumper
(3-pin CHASSIS_ID0)
(see p.6, No. 28)



Pull-up, for BMC further
use (Default)



Pull-down, for BMC further
use

2.8 Onboard Headers and Connectors



Onboard headers and connectors are NOT jumpers. Do NOT place jumper caps over these headers and connectors. Placing jumper caps over the headers and connectors will cause permanent damage to the motherboard.

System Panel Header
(9-pin PANEL1)
(see p.6, No. 23)

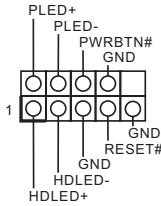

Connect the power switch, reset switch and system status indicator on the chassis to this header according to the pin assignments. Particularly note the positive and negative pins before connecting the cables.



PWRBTN (Power Switch):

Connect to the power switch on the chassis front panel. Configure the way to turn off the system using the power switch.

RESET (Reset Switch):

Connect to the reset switch on the chassis front panel. Press the reset switch to restart the computer if the computer freezes and fails to perform a normal restart.

PLED (System Power LED):

Connect to the power status indicator on the chassis front panel. The LED is on when the system is operating. The LED is off when the system is in S4 sleep state or powered off (S5).

HDLED (Hard Drive Activity LED):

Connect to the hard drive activity LED on the chassis front panel. The LED is on when the hard drive is reading or writing data.

The front panel design may differ by chassis. A front panel module mainly consists of power switch, power LED, hard drive activity LED, speaker and etc. When connecting the chassis front panel module to this header, make sure the wire assignments and the pin assignments are matched correctly.

Auxiliary Panel Header
(18-pin AUX PANEL1)
(see p.6, No. 21)

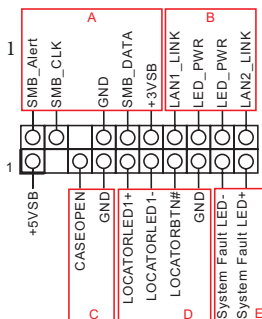

This header supports multiple functions on the front panel, including the front panel SMB, internet status indicator and chassis intrusion pin.



A. Front panel SMBus connecting pin (6-1 pin FPSMB)

This header allows user to connect SMBus (System Management Bus) equipment. It can be used for communication between peripheral equipment in the system, which has slower transmission rates, and power management equipment.

B. Internet status indicator (2-pin LAN1_LED, LAN2_LED)

These headers allow user to use the Gigabit internet indicator cable to connect to the LAN status indicator. When this indicator flickers, it means that the internet is properly connected.

C. Chassis intrusion pin (2-pin CHASSIS)

This header is provided for host computer chassis with chassis intrusion detection designs. In addition, it must also work with external detection equipment, such as a chassis intrusion detection sensor or a microswitch. When this function is activated, if any chassis component movement occurs, the sensor will immediately detect it and send a signal to this header, and the system will then record this chassis intrusion event. The default setting is set to the CASEOPEN and GND pin; this function is off.

D. Locator LED (4-pin LOCATOR)

This header is for the locator switch and LED on the front panel.

E. System Fault LED (2-pin SYSTEM STATUS)

This header is for the Fault LED on the system.

PWM Configuration Header
(3-pin PWM_CFG1)
(see p.6, No. 14)



This header is used for PWM configurations.

Chassis Speaker Header
(4-pin SPEAKER1)
(see p.6, No. 17)

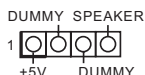

Please connect the chassis speaker to this header.

USB 3.2 Gen1 Header
(19-pin USB3_3_4)
(see p.6, No. 24)

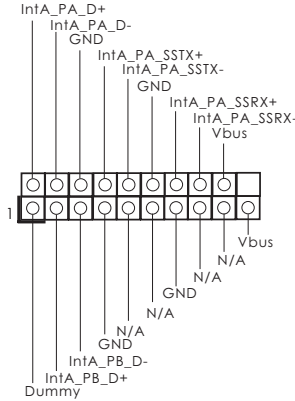

Besides two default USB 3.2 Gen1 ports on the I/O panel, there is one USB 3.2 Gen1 header on this motherboard. This header supports one USB 3.2 Gen1 port and two USB2.0 port.

System Fan Connectors
(6-pin FAN1)

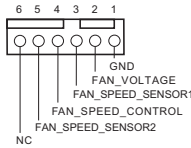

Please connect fan cables to the fan connectors and match the black wire to the ground pin. All fans support Fan Control.

- (see p.6, No. 9)
- (6-pin FAN2)
(see p.6, No. 19)
- (6-pin FAN3)
(see p.6, No. 20)
- (6-pin FAN4)
(see p.6, No. 18)
- (6-pin FAN5)
(see p.6, No. 22)
- (6-pin FAN6)
(see p.6, No. 11)
- (6-pin FAN7)
(see p.6, No. 10)

ATX 12V Power Connectors
(8-pin ATX12V1)
(see p.6, No. 4)
(8-pin ATX12V2)
(see p.6, No. 5)

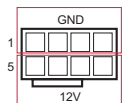

This motherboard provides two 8-pin ATX 12V power connectors.

Clear CMOS Pad
(CLR_CMOS1)
(see p.6, No. 7)



This allows user to clear the data in CMOS. To clear CMOS, take out the CMOS battery and short the Clear CMOS Pad.

ATX Power Connector
(24-pin ATXPWR1)
(see p.6, No. 8)

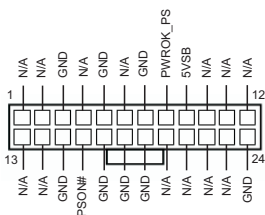

This motherboard provides a 24-pin ATX power connector. To use a 20-pin ATX power supply, please plug it along Pin 1 and Pin 13.

SATA Power Connector
(4-pin SATA_PWR1)
(see p.6, No. 2)

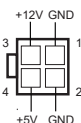

Please use a SATA power cable to connect this SATA Power Connector and the SATA HDD for supplying power from the motherboard, when using DC-IN mode without SATA power supply.

SPI TPM Header
(13-pin TPM_BIOS_PH1)
(see p.6, No. 13)

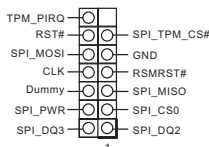

This connector supports Trusted Platform Module (TPM) system for SPI interface, which can securely store keys, digital certificates, passwords, and data. A TPM system also helps enhance network security, protects digital identities, and ensures platform integrity.

PSU SMBus Header
(5-pin PSU_SMB1)
(see p.6, No. 6)

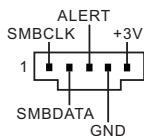

PSU SMBus monitors the status of the power supply, fan and system temperature.

Baseboard Management
Controller SMBus Header
(5-pin BMC_SMB1)
(see p.6, No. 29)

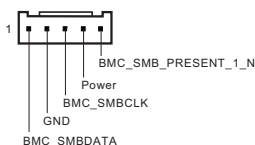

The header is used for the SM BUS devices.

Intelligent Platform
Management Bus Header
(4-pin IPMB1)
(see p.6, No. 30)

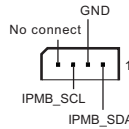

This 4-pin connector is used to provide a cabled base-board or front panel connection for value added features and 3rd-party add-in cards, such as Emergency Management cards, that provide management features using the IPMB.

Serial ATA3 Connectors
(SATA2)
(see p.6, No. 33)
(SATA3)
(see p.6, No. 31)

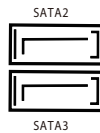

These two SATA3 connectors support SATA data cables for internal storage devices with up to 6.0Gb/s data transfer rate.

MicroSD Card Slot
(SD_CARD1)
(see p.6, No. 32)

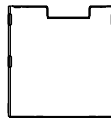

Carefully insert the SD Card into the slot until it clicks.

Mini Cool Edge IO
Connectors
(MCIO1)
(see p.6, No. 16)
(MCIO2)
(see p.6, No. 15)

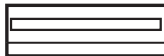

These connectors are used for the PCIE devices.

**MCIO1 shares lanes with SLOT6.*

1. MCIO1 will be disabled when SLOT6 is occupied by PCIe x16 device
2. MCIO1 will be fully functional when SLOT6 is occupied by PCIe x8 device or unoccupied

**MCIO2 shares lanes with 2 M.2:*

1. MCIO2 will be disabled when both M.2 are populated
2. MCIO2 will support PCIe x4 when 1 M.2 is populated

**When installing AMD Ryzen™ 8000 Series (Phoenix) Processors, MCIO1 will be disabled and MCIO2 will support only 2 PCIe4.0 x4*

**When installing AMD Ryzen™ 8000 Series (Phoenix2) Processors, MCIO1 will be disabled and MCIO2 will support only 1 PCIe4.0 x4 and 1 PCIe4.0 x2*

MCIO1 Pin Definition

Pin	Definition	Pin	Definition
A1	GND	B1	GND
A2	PCIE_RXP0	B2	PCIE_TXP0
A3	PCIE_RXN0	B3	PCIE_TXN0
A4	GND	B4	GND
A5	PCIE_RXP1	B5	PCIE_TXP1
A6	PCIE_RXN1	B6	PCIE_TXN1
A7	GND	B7	GND
A8	BP_TYPE	B8	SMB_SCL
A9	WAKE#	B9	SMB_SDA
A10	GND	B10	GND
A11	DP	B11	RST#
A12	DN	B12	PRSNT#
A13	GND	B13	GND
A14	PCIE_RXP2	B14	PCIE_C_TXP2
A15	PCIE_RXN2	B15	PCIE_C_TXN2
A16	GND	B16	GND
A17	PCIE_RXP3	B17	PCIE_C_TXP3
A18	PCIE_RXN3	B18	PCIE_C_TXN3
A19	GND	B19	GND
A20	PCIE_RXP4	B20	PCIE_C_TXP4
A21	PCIE_RXN4	B21	PCIE_C_TXN4
A22	GND	B22	GND
A23	PCIE_RXP5	B23	PCIE_C_TXP5
A24	PCIE_RXN5	B24	PCIE_C_TXN5
A25	GND	B25	GND
A26	BP_TYPE	B26	SMB_SCL
A27	WAKE#	B27	SMB_SDA
A28	GND	B28	GND
A29	DP	B29	RST#
A30	DN	B30	PRSNT#
A31	GND	B31	GND
A32	PCIE_RXP6	B32	PCIE_C_TXP6
A33	PCIE_RXN6	B33	PCIE_C_TXN6
A34	GND	B34	GND
A35	PCIE_RXP7	B35	PCIE_C_TXP7
A36	PCIE_RXN7	B36	PCIE_C_TXN7
A37	GND	B37	GND
75	NP_NC_1	76	NP_NC_2
77	PGND_1	78	PGND_3
79	PGND_2	80	PGND_4

MCIO2 Pin Definition

Pin	Definition	Pin	Definition
A1	GND	B1	GND
A2	PCIE_RXP0	B2	PCIE_TXP0
A3	PCIE_RXN0	B3	PCIE_TXN0
A4	GND	B4	GND
A5	PCIE_RXP1	B5	PCIE_TXP1
A6	PCIE_RXN1	B6	PCIE_TXN1
A7	GND	B7	GND
A8	BP_TYPE	B8	SMB_SCL
A9	WAKE#	B9	SMB_SDA
A10	GND	B10	GND
A11	DP	B11	RST#
A12	DN	B12	PRSNT#
A13	GND	B13	GND
A14	PCIE_RXP2	B14	PCIE_C_TXP2
A15	PCIE_RXN2	B15	PCIE_C_TXN2
A16	GND	B16	GND
A17	PCIE_RXP3	B17	PCIE_C_TXP3
A18	PCIE_RXN3	B18	PCIE_C_TXN3
A19	GND	B19	GND
A20	PCIE_RXP4	B20	PCIE_C_TXP4
A21	PCIE_RXN4	B21	PCIE_C_TXN4
A22	GND	B22	GND
A23	PCIE_RXP5	B23	PCIE_C_TXP5
A24	PCIE_RXN5	B24	PCIE_C_TXN5
A25	GND	B25	GND
A26	BP_TYPE	B26	SMB_SCL
A27	WAKE#	B27	SMB_SDA
A28	GND	B28	GND
A29	DP	B29	RST#
A30	DN	B30	PRSNT#
A31	GND	B31	GND
A32	PCIE_RXP6	B32	PCIE_C_TXP6
A33	PCIE_RXN6	B33	PCIE_C_TXN6
A34	GND	B34	GND
A35	PCIE_RXP7	B35	PCIE_C_TXP7
A36	PCIE_RXN7	B36	PCIE_C_TXN7
A37	GND	B37	GND
75	NP_NC_1	76	NP_NC_2
77	PGND_1	78	PGND_3
79	PGND_2	80	PGND_4

2.9 Dr. Debug

Dr. Debug is used to provide code information, which makes troubleshooting even easier. Please see the diagrams below for reading the Dr. Debug codes.

Code	Description
0x10	PEI_CORE_STARTED
0x11	PEI_CAR_CPU_INIT
0x15	PEI_CAR_NB_INIT
0x19	PEI_CAR_SB_INIT
0x31	PEI_MEMORY_INSTALLED
0x32	PEI_CPU_INIT
0x33	PEI_CPU_CACHE_INIT
0x34	PEI_CPU_AP_INIT
0x35	PEI_CPU_BSP_SELECT
0x36	PEI_CPU_SMM_INIT
0x37	PEI_MEM_NB_INIT
0x3B	PEI_MEM_SB_INIT
0x4F	PEI_DXE_IPL_STARTED
0x60	DXE_CORE_STARTED
0x61	DXE_NVRAM_INIT
0x62	DXE_SBRUN_INIT

0x63	DXE_CPU_INIT
0x68	DXE_NB_HB_INIT
0x69	DXE_NB_INIT
0x6A	DXE_NB_SMM_INIT
0x70	DXE_SB_INIT
0x71	DXE_SB_SMM_INIT
0x72	DXE_SB_DEVICES_INIT
0x78	DXE_ACPI_INIT
0x79	DXE_CSM_INIT
0x90	DXE_BDS_STARTED
0x91	DXE_BDS_CONNECT_DRIVERS
0x92	DXE_PCI_BUS_BEGIN
0x93	DXE_PCI_BUS_HPC_INIT
0x94	DXE_PCI_BUS_ENUM
0x95	DXE_PCI_BUS_REQUEST_RESOURCES
0x96	DXE_PCI_BUS_ASSIGN_RESOURCES
0x97	DXE_CON_OUT_CONNECT
0x98	DXE_CON_IN_CONNECT

0x99	DXE_SIO_INIT
0x9A	DXE_USB_BEGIN
0x9B	DXE_USB_RESET
0x9C	DXE_USB_DETECT
0x9D	DXE_USB_ENABLE
0xA0	DXE_IDE_BEGIN
0xA1	DXE_IDE_RESET
0xA2	DXE_IDE_DETECT
0xA3	DXE_IDE_ENABLE
0xA4	DXE_SCSI_BEGIN
0xA5	DXE_SCSI_RESET
0xA6	DXE_SCSI_DETECT
0xA7	DXE_SCSI_ENABLE
0xA8	DXE_SETUP_VERIFYING_PASSWORD
0xA9	DXE_SETUP_START
0xAB	DXE_SETUP_INPUT_WAIT
0xAD	DXE_READY_TO_BOOT
0xAE	DXE_LEGACY_BOOT

0xAF	DXE_EXIT_BOOT_SERVICES
0xB0	RT_SET_VIRTUAL_ADDRESS_MAP_BEGIN
0xB1	RT_SET_VIRTUAL_ADDRESS_MAP_END
0xB2	DXE_LEGACY_OPROM_INIT
0xB3	DXE_RESET_SYSTEM
0xB4	DXE_USB_HOTPLUG
0xB5	DXE_PCI_BUS_HOTPLUG
0xB6	DXE_NVRAM_CLEANUP
0xB7	DXE_CONFIGURATION_RESET
0xF0	PEI_RECOVERY_AUTO
0xF1	PEI_RECOVERY_USER
0xF2	PEI_RECOVERY_STARTED
0xF3	PEI_RECOVERY_CAPSULE_FOUND
0xF4	PEI_RECOVERY_CAPSULE_LOADED
0xE0	PEI_S3_STARTED
0xE1	PEI_S3_BOOT_SCRIPT
0xE2	PEI_S3_VIDEO_REPOST

0xE3	PEI_S3_OS_WAKE
0x50	PEI_MEMORY_INVALID_TYPE
0x53	PEI_MEMORY_NOT_DETECTED
0x55	PEI_MEMORY_NOT_INSTALLED
0x57	PEI_CPU_MISMATCH
0x58	PEI_CPU_SELF_TEST_FAILED
0x59	PEI_CPU_NO_MICROCODE
0x5A	PEI_CPU_ERROR
0x5B	PEI_RESET_NOT_AVAILABLE
0xD0	DXE_CPU_ERROR
0xD1	DXE_NB_ERROR
0xD2	DXE_SB_ERROR
0xD3	DXE_ARCH_PROTOCOL_NOT_AVAILABLE
0xD4	DXE_PCI_BUS_OUT_OF_RESOURCES
0xD5	DXE_LEGACY_OPROM_NO_SPACE
0xD6	DXE_NO_CON_OUT
0xD7	DXE_NO_CON_IN

0xD8	DXE_INVALID_PASSWORD
0xD9	DXE_BOOT_OPTION_LOAD_ERROR
0xDA	DXE_BOOT_OPTION_FAILED
0xDB	DXE_FLASH_UPDATE_FAILED
0xDC	DXE_RESET_NOT_AVAILABLE
0xE8	PEI_MEMORY_S3_RESUME_FAILED
0xE9	PEI_S3_RESUME_PPI_NOT_FOUND
0xEA	PEI_S3_BOOT_SCRIPT_ERROR
0xEB	PEI_S3_OS_WAKE_ERROR

2.10 Unit Identification purpose LED/Switch

Use the UID button to locate the server working on behind a rack of servers.

Unit Identification
purpose LED/Switch
(UID1)



When the UID button on the front or rear panel is pressed, the front/rear UID blue LED indicator will be turned on. Press the UID button again to turn off the indicator.



- 1. Press and hold the UID button for 4 seconds, the BMC will trigger an external reset.*
- 2. Press and hold the UID button for 10 seconds, the BMC will reset and load default values.*

2.11 M.2 SSD Module Installation Guide

The M.2 Socket (2 Key M, M2_1/M2_2) supports type 2280/2242 M.2 PCI Express module up to Gen5 x4 (32GT/s x4).

- * When installing AMD Ryzen™ 8000 Series (Phoenix) Processors.
 - 2 M.2 supports PCIe4.0 x4.
- * When installing AMD Ryzen™ 8000 Series (Phoenix 2) Processors.
 - M2_1 supports PCIe4.0 x2 and M2_2 supports PCIe4.0 x4.
- * M.2 shares lanes with M.2.
 - M.2 will support only PCIe5.0 x4 when 1 M.2 is populated.
 - M.2 will disable when 2 M.2 are populated.
 - M.2 will support PCIe x4 when 1 M.2 is populated.

Installing the M.2 SSD Module

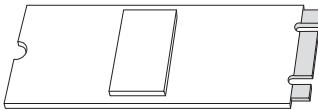

Step 1

Prepare a M.2 SSD module and the screw.

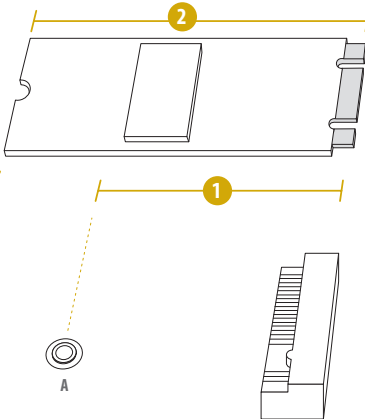

Step 2

Depending on the PCB type and length of the M.2 SSD module, find the corresponding nut location to be used.

No.	1	2
Nut Location	A (NUT42_1/2)	B (NUT80_1/2)
PCB Length	4.2cm	8cm
Module Type	Type 2242	Type 2280

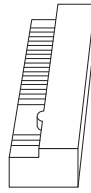
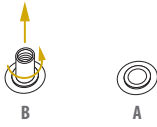

Step 3

Move the standoff based on the module type and length.
Skip Step 3 and 4 and go straight to Step 5 if going to use the default nut.
Otherwise, release the standoff by hand.

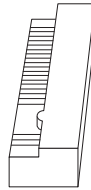

Step 4

Peel off the yellow protective film on the nut to be used. Hand tighten the standoff into the desired nut location on the motherboard.

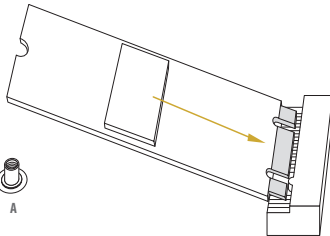

Step 5

Align and gently insert the M.2 SSD module into the M.2 slot. Please be aware that the M.2 SSD module only fits in one orientation.

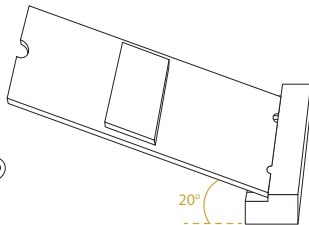

Step 6

Tighten the screw with a screwdriver to secure the module into place. Please do not overtighten the screw as this might damage the module.

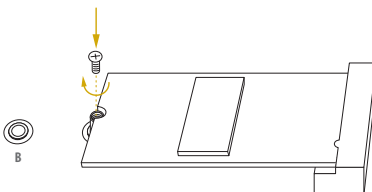

Chapter 3 UEFI Setup Utility

3.1 Introduction

This section explains how to use the UEFI SETUP UTILITY to configure the system. The UEFI chip on the motherboard stores the UEFI SETUP UTILITY. Run the UEFI SETUP UTILITY when starting up the computer. Please press <F2> or during the Power-On-Self-Test (POST) to enter the UEFI SETUP UTILITY; otherwise, POST will continue with its test routines.

Restart the system by pressing <Ctrl> + <Alt> + <Delete> to enter the UEFI SETUP UTILITY after POST, or by pressing the reset button on the system chassis. This allows user to restart by turning the system off and then back on.



Because the UEFI software is constantly being updated, the following UEFI setup screens and descriptions are for reference purpose only, and they may not exactly match what seeing on the screen.

3.1.1 UEFI Menu Bar

The top of the screen has a menu bar with the following selections:

Item	Description
Main	To set up the system time/date information
Advanced	To set up the advanced UEFI features
Security	To set up the security features
Server Mgmt	To manage the server
Boot	To set up the default system device to locate and load the Operating System
Exit	To exit the current screen or the UEFI SETUP UTILITY

Use <←> key or <→> key to choose among the selections on the menu bar, and then press <Enter> to get into the sub screen.

3.1.2 Navigation Keys

Please check the following table for the function description of each navigation key.

Navigation Key(s)	Function Description
← / →	Moves cursor left or right to select Screens
↑ / ↓	Moves cursor up or down to select items
+ / -	To change option for the selected items
<Tab>	Switch to next function
<Enter>	To bring up the selected screen
<PGUP>	Go to the previous page
<PGDN>	Go to the next page
<HOME>	Go to the top of the screen
<END>	Go to the bottom of the screen
<F1>	To display the General Help Screen
<F7>	Discard changes and exit the UEFI SETUP UTILITY
<F9>	Load optimal default values for all the settings
<F10>	Save changes and exit the UEFI SETUP UTILITY
<F12>	Print screen
<ESC>	Jump to the Exit Screen or exit the current screen

3.2 Main Screen

Once entering the UEFI SETUP UTILITY, the Main screen will appear and display the system overview. The Main screen provides system overview information and allows user to set the system time and date.

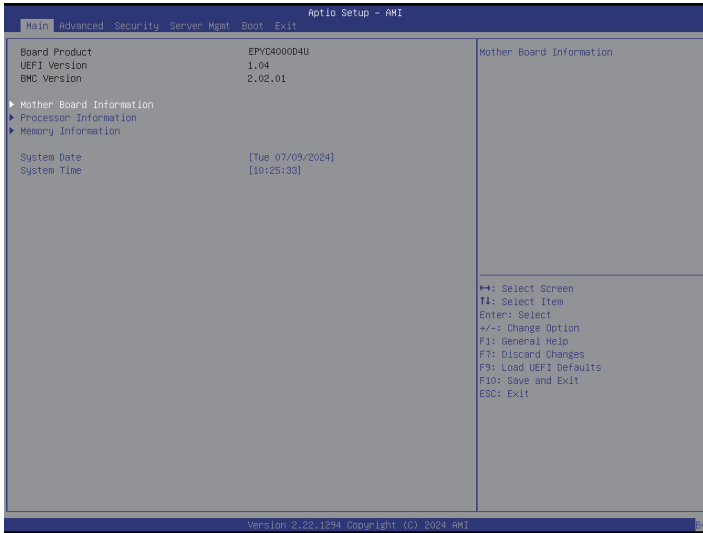

Because the UEFI software is constantly being updated, the following UEFI setup screens and descriptions for reference purpose only, and may vary from the latest BIOS and do not exactly match what seeing on the screen.

3.2.1 Motherboard Information

Press [Enter] to view the information of the motherboard.



3.2.2 Processor Information

Press [Enter] to view the information of the processor.

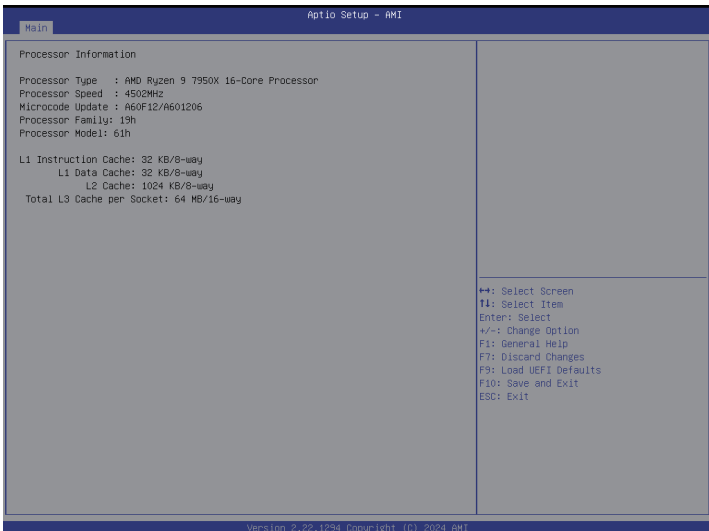

3.2.3 Memory Information

Press [Enter] to view the information of the memory.

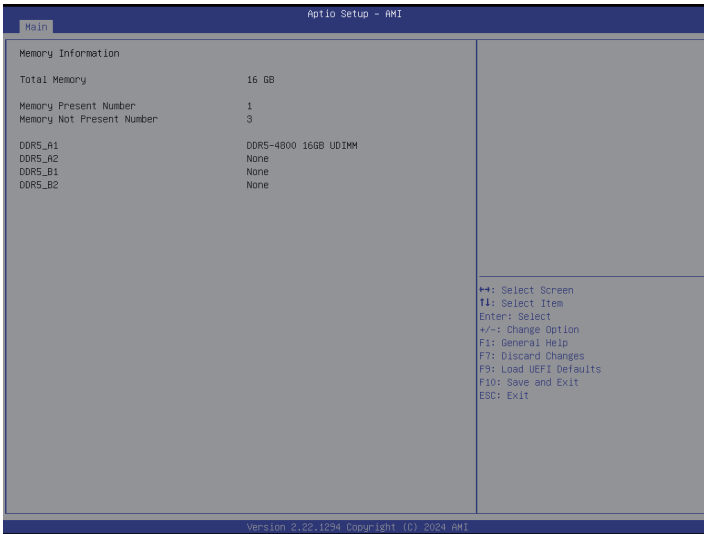

3.3 Advanced Screen

In this section, set the configurations for the following items: CPU Configuration, Chipset Configuration, Storage Configuration, NVMe Configuration, ACPI Configuration, USB Configuration, Super IO Configuration, Serial Port Console Redirection, H/W Monitor, PCI Subsystem Settings, AMD CBS, Trusted Computing, Network Stack Configuration, Driver Health, Tls Auth Configuration, AMD PBS, AMD Overclocking, Intel(R) Ethernet Controller I226-LM, VLAN Configuration, MAC Network Configurations and Instant Flash.

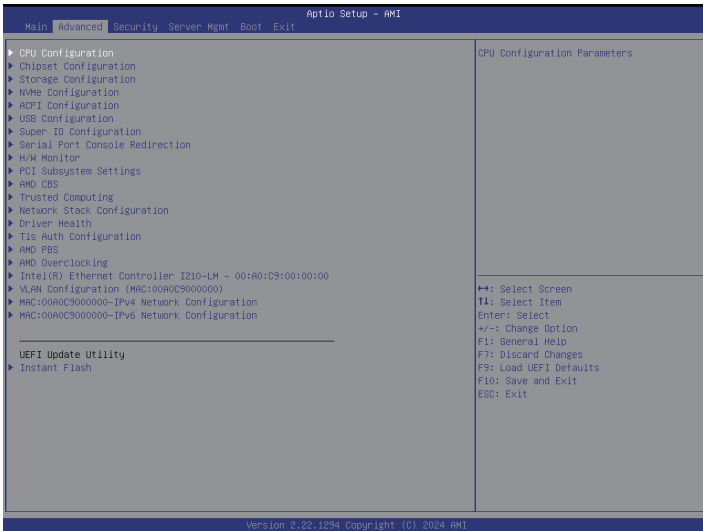

Setting wrong values in this section may cause the system to malfunction.

3.3.1 CPU Configuration

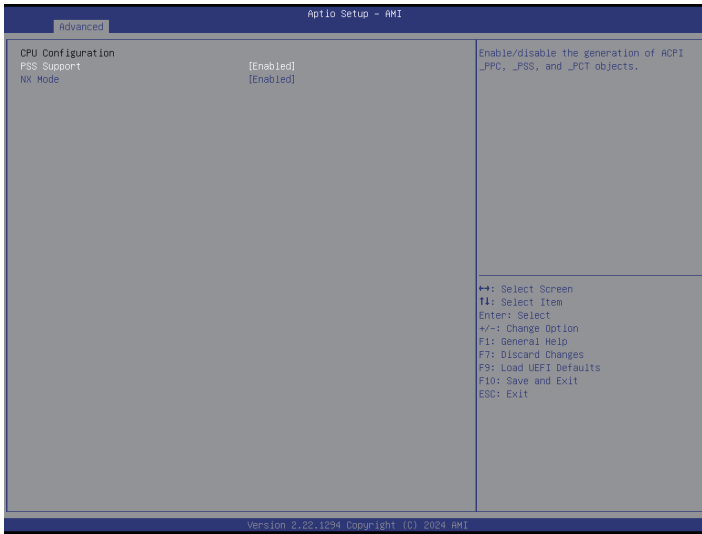

PSS Support

Use this item to enable or disable the generation of ACPI _PPC, _PSS, and _PCT objects.

NX Mode

Use this item to enable or disable No-execute page protection Function.

3.3.2 Chipset Configuration

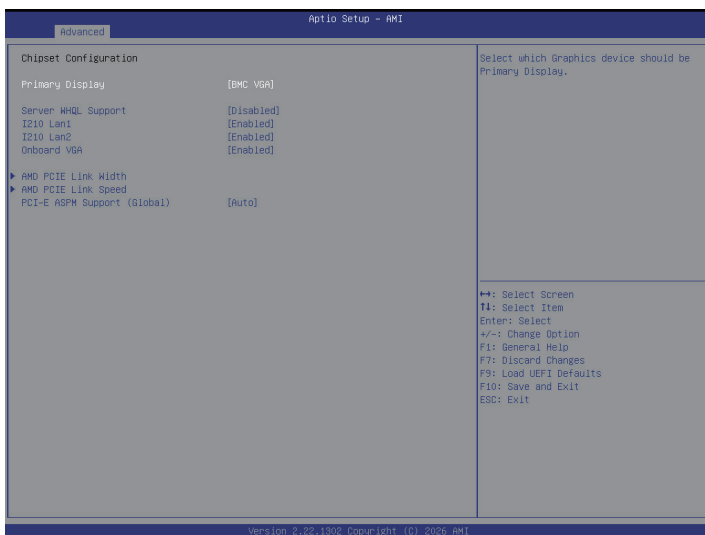

Primary Display

Select which Graphics device as the Primary Display.

Server WHQL Support

Use this to enable or disable the Server WHQL Support.

If using Windows Server 2022 or Windows Server 2025, please enable this option.

Onboard I210 Lan1

Use this to enable or disable the Onboard I210 Lan1 function.

Onboard I210 Lan2

Use this to enable or disable the Onboard I210 Lan2 function.

Onboard VGA

Use this to enable or disable the Onboard VGA function.

AMD PCIE Link Width

Select this item to configure PCIE Link Width.

PCIE6 Link Width

Configure PCIE6 Link Width, the default value is [x16]. Options: [x16], [x8x8], [x8x4x4], [x4x4x8] and [x4x4x4x4].

AMD PCIE Link Speed

Select this item to configure PCIE Link Speed.

PCIE6 Link Speed

Configure the PCIE6 Link Speed.

M2_1 Link Speed

Configure the M2_1 Link Speed.

PCI-E ASPM Support (Global)

Use this item to enable or disable the ASPM support for CPU downstream devices.

3.3.3 Storage Configuration

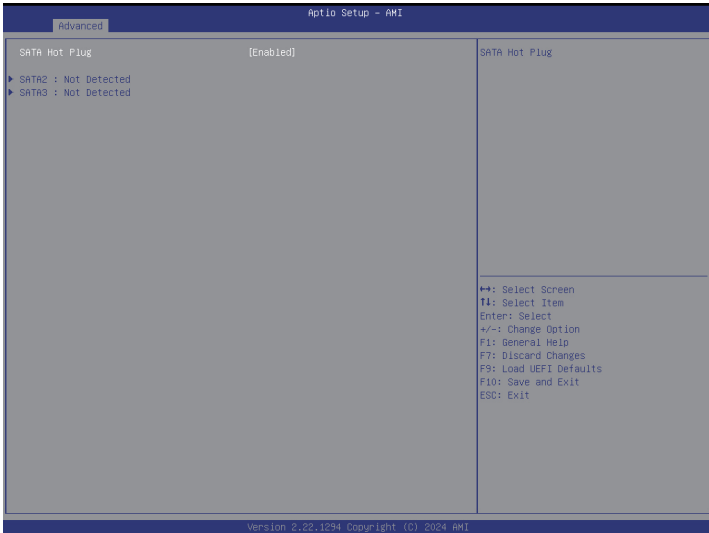

SATA Hot Plug

Use this item to enable or disable SATA Hot Plug.

3.3.4 NVMe Configuration



NVMe Configuration

The NVMe Configuration displays the NVMe controller and Drive information.

3.3.5 ACPI Configuration

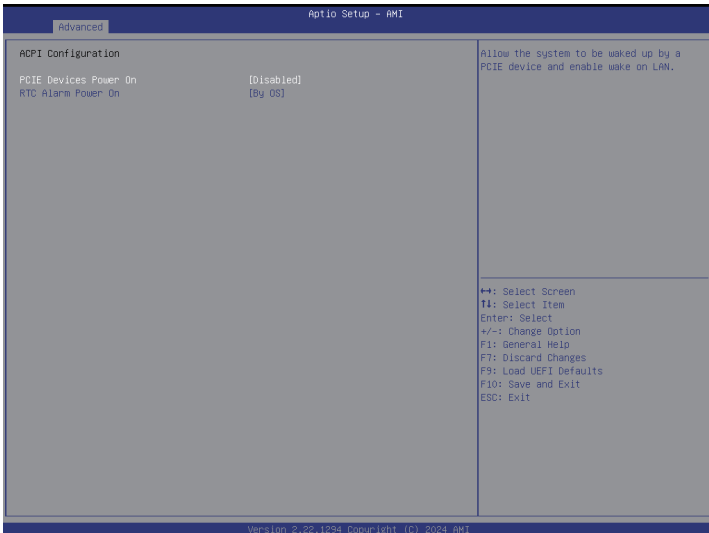

PCIE Devices Power On

This Allows the system to be waked up by a PCIE device and enable wake on LAN.

RTC Alarm Power On

This Allows the system to be waked up by the real time clock alarm. Set it to By OS to let it be handled by operating system.

RTC Alarm Date

Use this item to set Date of RTC power on feature.

RTC Alarm Hour

Use this item to set Hour of RTC power on feature.

RTC Alarm Minute

Use this item to set Minute of RTC power on feature.

RTC Alarm Second

Use this item to set Second of RTC power on feature.

3.3.6 USB Configuration

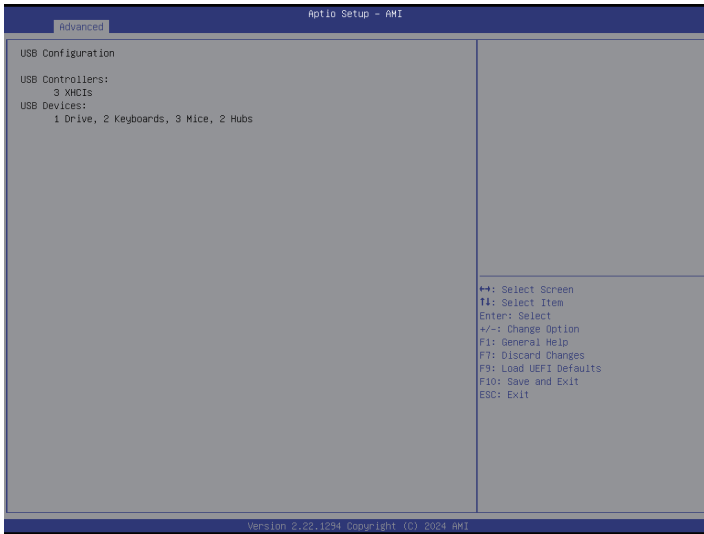

USB Configuration

The USB Configuration displays the USB Controllers and USB Devices informations.

3.3.7 Super IO Configuration

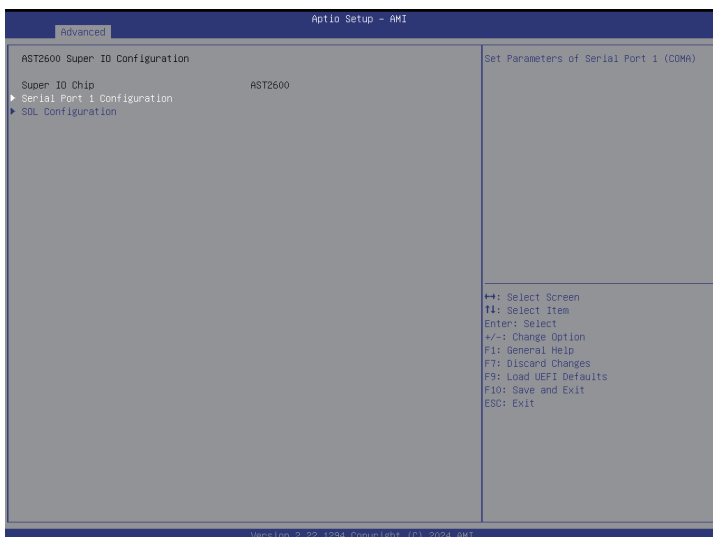

Serial Port 1 Configuration

Use this item to set parameters of Serial Port 1 (COMA).

Serial Port

Use this item to enable or disable the serial port.

Serial Port Address

Use this item to select an optimal setting for Super IO device.

SOL Configuration

Use this item to set parameters of SOL.

Serial Port

Use this item to enable or disable Serial Port (COM).

Serial Port Address

Use this item to select an optimal setting for Super IO device.

3.3.8 Serial Port Console Redirection

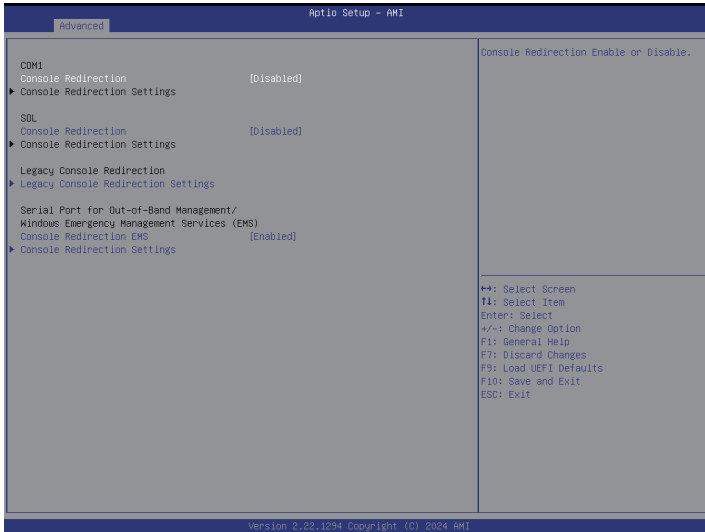

COM1 / SOL

Console Redirection

Use this option to enable or disable Console Redirection. If this item is set to Enabled, select a COM Port to be used for Console Redirection.

Console Redirection Settings

Use this option to configure Console Redirection Settings, and specify how the host computer and the remote computer (which the user is using) will exchange data. Both computers should have the same or compatible settings.

Terminal Type

Use this item to select the preferred terminal emulation type for out-of-band management. It is recommended to select [VT-UTF8].

Option	Description
VT100	ASCII character set
VT100Plus	Extended VT100 that supports color and function keys
VT-UTF8	UTF8 encoding is used to map Unicode chars onto 1 or more bytes
ANSI	Extended ASCII character set

Bits Per Second

Use this item to select the serial port transmission speed. The speed used in the host computer and the client computer must be the same. Long or noisy lines may require lower transmission speed. The options include [9600], [19200], [38400], [57600] and [115200].

Data Bits

Use this item to set the data transmission size. The options include [7] and [8] (Bits).

Parity

Use this item to select the parity bit. The options include [None], [Even], [Odd], [Mark] and [Space].

Stop Bits

The item indicates the end of a serial data packet. The standard setting is [1] Stop Bit. Select [2] Stop Bits for slower devices.

Flow Control

Use this item to set the flow control to prevent data loss from buffer overflow. When sending data, if the receiving buffers are full, a "stop" signal can be sent to stop the data flow. Once the buffers are empty, a "start" signal can be sent to restart the flow. Hardware flow uses two wires to send start/stop signals. The options include [None] and [Hardware RTS/CTS].

VT-UTF8 Combo Key Support

Use this item to enable or disable the VT-UTF8 Combo Key Support for ANSI/VT100 terminals.

Recorder Mode

Use this item to enable or disable Recorder Mode to capture terminal data and send it as text messages.

Resolution 100x31

Use this item to enable or disable extended terminal resolution support.

Putty Keypad

Use this item to select Function Key and Keypad on Putty.

Legacy Console Redirection

Legacy Console Redirection Settings

Use this option to configure Legacy Console Redirection Settings, and specify how computer and host computer to which are connected to exchange information.

Redirection COM Port

Select a COM port to display redirection of Legacy OS and Legacy OPROM Messages.

Resolution

On Legacy OS, the Number of Rows and Columns supported redirection.

Redirect After POST

When Bootloader is selected, then Legacy Console Redirection is disabled before booting to legacy OS. When Always Enable is selected, then Legacy Console Redirection is enabled for legacy OS. Default setting for this option is set to Always Enable.

Serial Port for Out-of-Band Management/Windows Emergency Management Services (EMS)

Console Redirection EMS

Use this option to enable or disable Console Redirection. If this item is set to Enabled, select a COM Port to be used for Console Redirection.

Console Redirection Settings

Use this option to configure Console Redirection Settings, and specify how the host computer and the remote computer (which the user is using) will exchange data. Both computers should have the same or compatible settings.

Out-of-Band Mgmt Port

Microsoft Windows Emergency Management Services (EMS) allows for remote management of a Windows Server OS through a serial port.

Terminal Type EMS

Use this item to select the preferred terminal emulation type for out-of-band management. It is recommended to select [VT-UTF8].

Option	Description
VT100	ASCII character set
VT100+	Extended VT100 that supports color and function keys
VT-UTF8	UTF8 encoding is used to map Unicode chars onto 1 or more bytes
ANSI	Extended ASCII character set

Bits Per Second EMS

Use this item to select the serial port transmission speed. The speed used in the host computer and the client computer must be the same. Long or noisy lines may require lower transmission speed. The options include [9600], [19200], [57600] and [115200].

Flow Control EMS

Use this item to set the flow control to prevent data loss from buffer overflow. When sending data, if the receiving buffers are full, a "stop" signal can be sent to stop the data flow. Once the buffers are empty, a "start" signal can be sent to restart the flow. Hardware flow uses two wires to send start/stop signals. The options include [None], [Hardware RTS/CTS], and [Software Xon/Xoff].

Data Bits

Parity

Stop Bits

3.3.9 H/W Monitor

In this section, it allows us to monitor the status of the hardware on the system, including the parameters of the CPU temperature, motherboard temperature, CPU fan speed, chassis fan speed, and the critical voltage.

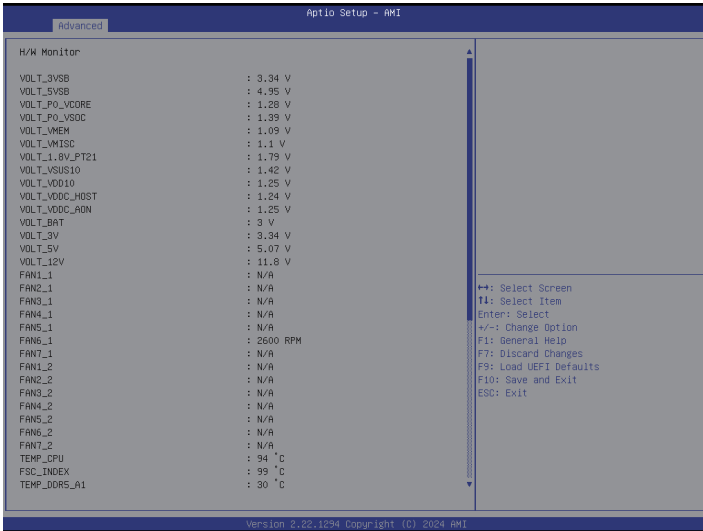

3.3.10 PCI Subsystem Settings



Re-Size BAR Support

If system has Resizable BAR capable PCIe Devices, this option Enables/Disables Resizable BAR support.

SR-IOV Support

If system has SR-IOV capable PCIe Devices, this option Enables/Disables Single Root IO Virtualization Support.

BME DMA Mitigation

Re-enable Bus Master Attribute disabled during Pci enumeration for PCI Bridges after SMM Locked.

Hot-Plug Support

Use this item to enable or disable Hot-Plug support for the entire system. If System has Hot-Plug capable Slots and this option set to Enabled, it provides a Setup screen for selecting PCI resource padding for Hot-Plug.



*Changing PCI Device(s) settings may have unwanted side effects! System may HANG!
PROCEED WITH CAUTION.*

3.3.11 AMD CBS

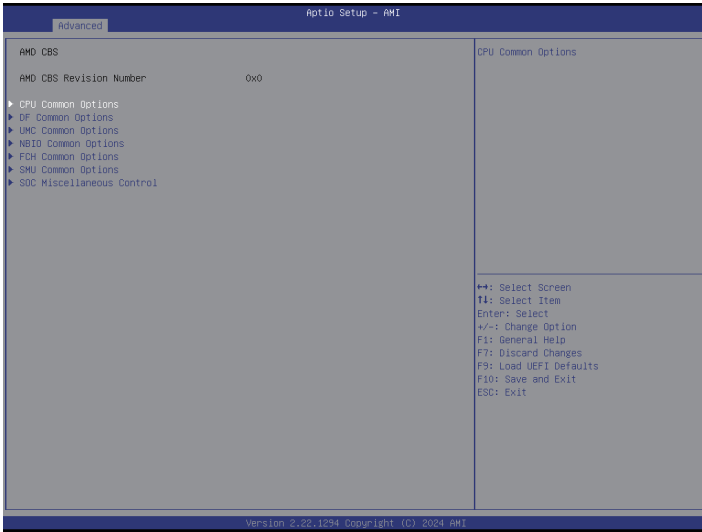

CPU Common Options

Use this item to configure CPU common options.

Thread Enablement

Use this item to configure Thread Enablement.

Performance

Use this item to configure CPU performance.

Prefetcher Settings

Use this item to configure L1 Stream HW, L1 Stride, L1 Region, L2 Stream HW, L2 Up/Down and L1 Burst Prefetcher Settings.

Core Watchdog

Use this item to configure CPU Watchdog Timer.

RedirectForReturnDis

From a workaround for GCC/C000005 issue for XV Core on C2 A0, setting MSRC001_1029 Decode Configuration (DE_CFG) bit 14 [DecfgNoRdrctForReturns] to 1.

Core Performance Boost

Use this item to configure Core Performance Boost.

Global C-state Control

Use this item to controls IO based C-state generation and DF C-states.

Power Supply Idle Control

Use this item to configure Power Supply Idle Control.

Streaming Stores Control

Use this item to enable or disable the streaming stores functionality.

Local APIC Mode

Use this item to configure local APIC operation modes.

ACPI_CST C1 Declaration

Determines whether or not to declare the C1 state to the OS.

Platform First Error Handling

Use this to enable or disable PFEH, cloak individual banks, and mask deferred error interrupts from each bank.

MCA Error Thresh Enable

Use this item to enable MCA error thresholding.

MCA FruText

Use this item to enable or disable MCA FruText.

SMU and PSP Debug Mode

When this option is enabled, uncorrected errors detected by the PSP FW or SMU FW that should cause a cold reset, will hang and not reset the system.

PPIN Opt-in

Use this item to turn on PPIN feature.

REP-MOV/STOS Streaming

This item allows REP-MOVS/STOS to use non-caching streaming stores for large sizes.

Enhanced REP MOVSB/STOSB

The Default value is 1, also can be set to zero for analysis purposes as long as OS support it.

Fast Short REP MOVSB (FSRM)

The Default value is 1, also can be set to zero for analysis purposes as long as OS support it.

SNP Memory (RMP Table) Coverage

Configure this item to enable, the entire system memory is covered.

SMEE

Use this item to control secure memory encryption enable. Enabling both SMEE and SME-MK are not supported. Results in #GP.

Action on BIST Failure

When a CCD BIST failure is detected, the action will be taken.

Log Transparent Errors

Log transparent errors in MCA in addition to debug registers.

AVX512

Use this item to enable or disable AVX512.

MONITOR and MWAIT disable

The MONITOR, MWAIT, MONITORX, and MWAITX opcodes become invalid, when Enabled.

Corrector Branch Predictor

Enabling for branch heavy codes may reduce conditional branch mispredicts.

PAUSE Delay

Number of cycles thread will be idle after a PAUSE instruction.

CPU Speculative Store Modes

Balanced: Store instructions may delay sending out their invalidations to remote cacheline copies when the cacheline is present but not in a writable state in the local cache.

More Speculative: Store instructions will send out invalidations to remote cacheline copies as soon as possible.

Less Speculative: Store instructions may delay sending out their invalidations to remote cacheline copies when the cacheline is not present in the local cache or not in a writable state in the local cache.

SVM Lock

Use this item to enable or disable VM_CR [Lock].

SVM Enable

Use this item to enable or disable VM_CR [SvmeDisable].

DF Common Options

Use this item to configure DF common options.

Memory Addressing

Use this item to configure memory addressing.

ACPI

Use this item to configure ACPI.

Disable DF to external downstream IP Sync Flood Propagation

Disables Error propagation to UMC or any downstream slaves eg. FCH. Use this to avoid reset in failure scenario.

Disable DF Sync Flood Propagation

Disables propagation from PIE to other DF components and eventually to SDP ports.

Freeze DF Module Queues on Error

Enables freezing of all DF queues on error and also forces a sync flood on HWA even if MCAs are disabled.

DF Cstates

When DF Cstate feature is enabled, FW programs the registers required to enable this feature in the DF HW. (For auto option, it means this option will be synchronized with Global C State.)

PSP Error Injection Support

Set this item [True] to enable EINJ support.

UMC Common Options

Use this item to configure UMC Common options including DDR Timing Configuration, DDR Bus Configuration, DDR Controller Configuration, DDR RAS, DDR Security, DDR Addressing Options, DDR Training Options, DDR Memory MBIST, DDR Memory Features and DDR Turnaround Times.

NBIO Common Options

Use this item to configure NBIO common options.

IOMMU

Use this item to enable or disable IOMMU.

PCIe ARI Support

Use this item to enable or disable ARI.

PCIe All Port ECRC

Use this item to enable or disable PCIe all port ECRC.

Advanced Error Reporting (AER)

Use this item to enable or disable the support for Advanced Error Reporting (AER).

PCIe ARI Enumeration

ARI Forwarding Enable for each downstream port.

GFX Configuration

Select this item to GFX.

PCIe Loopback Mode

Use this item to enable or disable PcieLoopBackMode.

Persistence Mode for Legacy Endpoints

Use this item to enable or disable persistence mode for legacy endpoints. Enable this item if some legacy PCIe devices are not detected.

EQ Bypass to Highest Rate

Controls the ability to advertise Equalization Bypass to Highest Rate Support in TSxs sent prior to LinkUp=1.

Retimer Margining Support

Auto is Disabled. Root port receiver margining support is enabled by default. Enabled - enables the support for margining a retimer. Disabled - Retimer margining is not supported.

FCH Common Options

Use this item to configure FCH Common options including I3C/I2C Configuration Options, USB Configuration Options, Ac Power Loss Options, ESPI Configuration Options and SPI Configuration Options.

FCH Spread Spectrum

Select whether or not Enable the spread Spectrum Feature.

SMU Common Options

Use this item to configure SMU common options.

TDP Control

Auto: Use the default sustained power limit.

Manual: User can set customized sustained power limit.

ECO Mode

Adjust CPU control limits to manage operation within a 65W thermal design power.

Enabled: Enables 65W processor power definition.

Disabled: System uses default processor power definition.

Enabled - 105W: Enables 105W processor power definition (170W OPNs only).

PPT Control

Specifies the PPT Control.

Thermal Control

Auto: Use the default TctlMax.

Manual: User can set customized TctlMax.

TDC Control

Auto: Use the default TDC limits.

Manual: User can set customized TDC limits.

EDC Control

Auto: Use the default EDC limits.

Manual: User can set customized EDC limits.

Fan Control

Auto: Use the default fan controller settings.

Manual: User can set customized fan controller settings.

VDDP Voltage Control

Auto: Use the default VDDP voltage.

Manual: User can set customized VDDP voltage.

Infinity Fabric Frequency and Dividers

Use this item to configure the Infinity Fabric Frequency and Dividers.

SyncFifo Mode Override

Use this item to configure the Sustained PowerLimit.

Fast PPT Limit

Use this item to configure the Fast PPT Limit.

Slow PPT Limit

Use this item to configure the Slow PPT Limit.

Slow PPT Time Constant

Use this item to configure the Slow PPT Time Constant (seconds).

GFXOFF

Use this item to enable or disable the GFXOFF feature.

SOC Miscellaneous Control

Use this item to configure SOC Miscellaneous control options.

Trusted Platform Module

Use this item to enable or disable the TPM physical presence. The default value is Auto for fTPM.

Pluton Security Processor

Use this item to enable or disable the Pluton Security Processor.

Microsoft Security Levels

This item provides one stop configuration for SCPC (Note: Firmware Anti-rollback is excluded). For Level 1, it will configure TPM, SVM, IOMMU, SecureBoot; For Level2, it will configure TPM, SVM, IOMMU, DMAR, SecureBIO, SecureBoot; For Level 3, it will configure TPM, SMM Isolation, SVM, IOMMU, DMAR, TSME, SecureBIO, SecureBoot, Modern Standby. Regard TPM configuraiton, dTPM refers to discrete TPM. Pluton fTOM refers to Pluton firmware TPM. ASP fPM refers t ASP firmware TPM.

Secured-core Auto enablement

Set this item to disable, AGESA will delete EFI variable 'BuiltAsSecuredCorePC' if detected. Set this item to enable, AGESA will set EFI variable 'Built AsSecuredCorePC' to non-zero value. If set 'BuiltAsSecuredCorePC' to non-zero, it will identify a device as Secure-core PC. If set this item to Auto, ignore, AGESA will do nothing.

DRTM Support

Use this item to enable the DRTM.

SMM Isolation Support

Use this item to enable SMM Isolation (as known as SMM Supervisor).

Pluton Options

Select this item to configure the Pluton Options.

Firmware Anti-rollback (FAR)

Select this item to configure the Firmware Anti-rollback (FAR).

AIM-T Options

Select this item to configure the AIM-T Options.

SecureBio

Select this item to configure the SecureBio Options.

ABL Console Out Control

Enable: Enable ConsoleOut Function for ABL.

Disable: Disable ConsoleOut Function for ABL.

Auto: Keep default behavior.

Note: Also need to enable ESPI ABL Init.

PSP RPMC Switch

Control RPMC usage.

Enable: Enable RPMC Function.

Disable: Disable RPMC Function.

Auto: Keep default behavior.

This option is for test purpose only, NOT FOR PRODUCTION!!!

Mixed DIMM config extended NUMA domain

Mixed DIMM config extended NUMA domain in SRAT that contain only non-interleaving memory region but no processor.

PROM21 Chipset Common Options

Use this item to configure PROM21 Chipset common options.

PROM21 Chipset PCIe Port Configuration Options

Select this item to configure the PROM21 Chipset PCIe Port Options.

PROM21 Chipset SATA Configuration Options

Select this item to configure the PROM21 Chipset SATA Options.

PROM21 Chipset USB Configuration Options

Select this item to configure the PROM21 Chipset USB Options.

USB Port Disablement Phase

Use this item to configure the USB Port Disablement Phase.

PROM21L.1/2/3/6/7 USB Port Configuration Options

Select this item to configure the PROM21L.1/2/3/6/7 USB Port Options.

PROM21 Chipset SI Configuration Options

Select this item to configure the PROM21 Chipset SI Options.

PROM21 Chipset Revision

Use this item to configure the PROM21 Chipset Revision.

Dual PROM21 Port Number/Disable

Set downstream port number for second PROM21. Disable this item if don't have the second PROM21.

PCIe Power Management Features

Use this item to configure the PCIe Power Management Features.

3.3.12 Trusted Computing

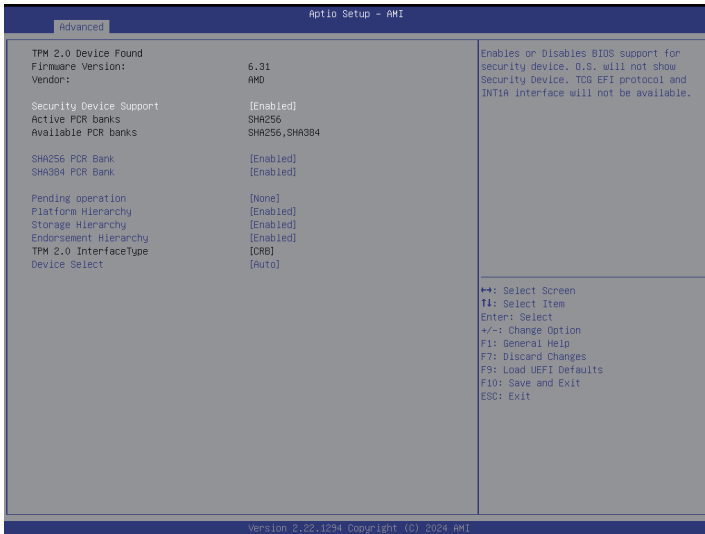

NOTE: Options vary depending on the version of the connected TPM module.

Security Device Support

Enable or disable BIOS support for security device. O.S. will not show Security Device. TCG EFI protocol and INT1A interface will not be available.

Active PCR Banks

This item displays active PCR Banks.

Available PCR Banks

This item displays available PCR Banks.

SHA256 PCR Bank

Use this item to enable or disable SHA256 PCR Bank

SHA384 PCR Bank

Use this item to enable or disable SHA384 PCR Bank.

Pending Operation

Schedule an Operation for the Security Device.

NOTE: The computer will reboot during restart in order to change State of the Device.

Platform Hierarchy

Use this item to enable or disable Platform Hierarchy.

Storage Hierarchy

Use this item to enable or disable Storage Hierarchy.

Endorsement Hierarchy

Use this item to enable or disable Endorsement Hierarchy.

TPM 2.0 InterfaceType (CRB)

Select the Communication Interface to TPM 2.0 Device

Device Select

Use this item to select the TPM device to be supported. TPM 1.2 will restrict support to TPM 1.2 devices. TPM 2.0 will restrict support to TPM 2.0 devices. Auto will support both with the default set to TPM 2.0 devices. If TPM 2.0 devices are not found, TPM 1.2 devices will be enumerated.

3.3.13 Network Stack Configuration

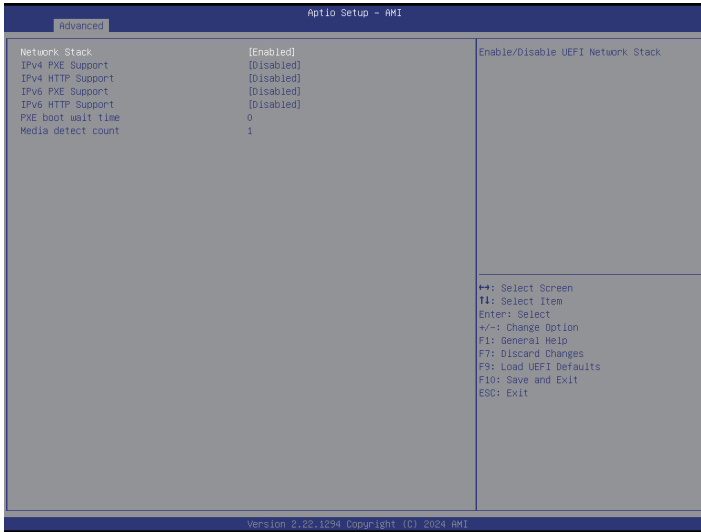

Network Stack

Enable UEFI network stack can prevents user from performing single-user network boots and network installation. If disabled, the host does not use the network interface.

IPv4 PXE Support

Enable IPv4 PXE Boot support. If disabled, IPv4 PXE Boot Option is not supported.

IPv4 HTTP Support

Enable IPv4 HTTP Boot support. If disabled, IPv4 HTTP Boot Option is not supported.

IPv6 PXE Support

Enable IPv6 PXE Boot support. If disabled, IPv6 PXE Boot Option is not supported.

IPv6 HTTP Support

Enable IPv6 HTTP Boot support. If disabled, IPv6 HTTP Boot Option is not supported.

PXE Boot Wait Time

Specifies the wait time and press the ESC key to abort the PXE boot.

Media Detect Count

Specifies the number of times the presence of physical storage device are verified on a system reset or power cycle.

3.3.14 Driver Health

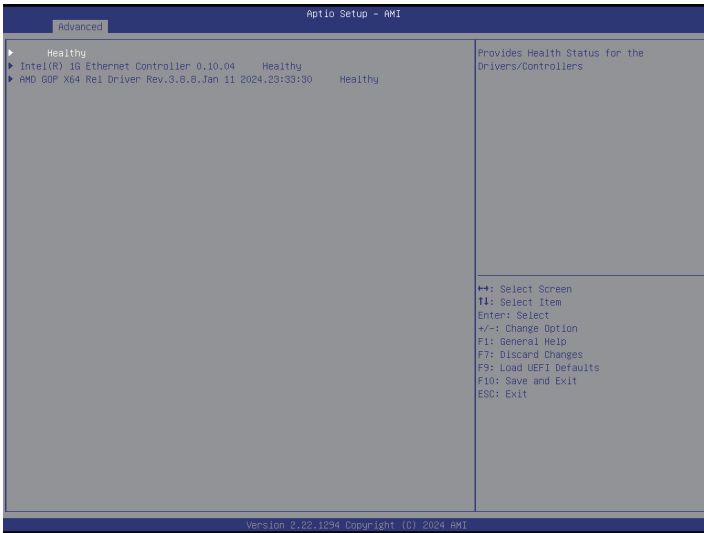

Intel(R) 1G Ethernet Controller 0.10.04 **Healthy**

Provides Health Status for the Drivers/Controllers.

AMD GOP X64 Rel Driver Rev.3.8.8.Jan 11 2024.23:33:30 **Healthy**

Provides Health Status for the Drivers/Controllers.

3.3.15 Tls Auth Configuration

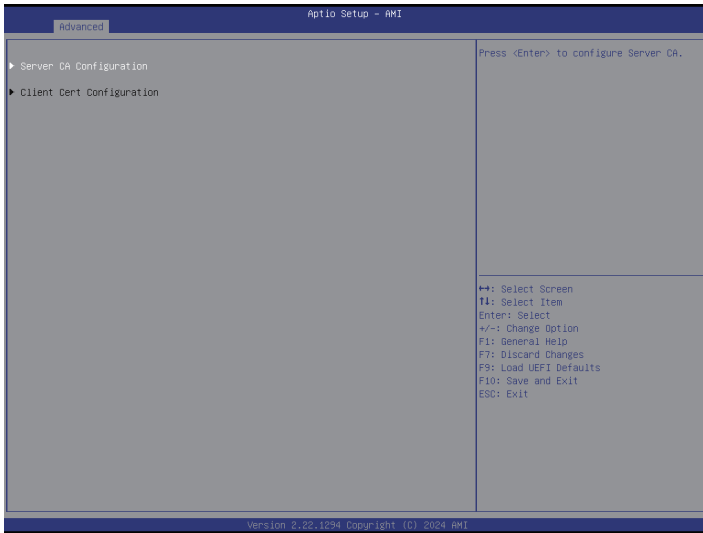

Server CA Configuration

Press [Enter] to configure Server CA.

Enroll Cert

Press <Enter> to enroll cert.

Delete Cert

Press <Enter> to delete cert.

Client Cert Configuration

Press [Enter] to configure Client Cert.

3.3.16 AMD PBS

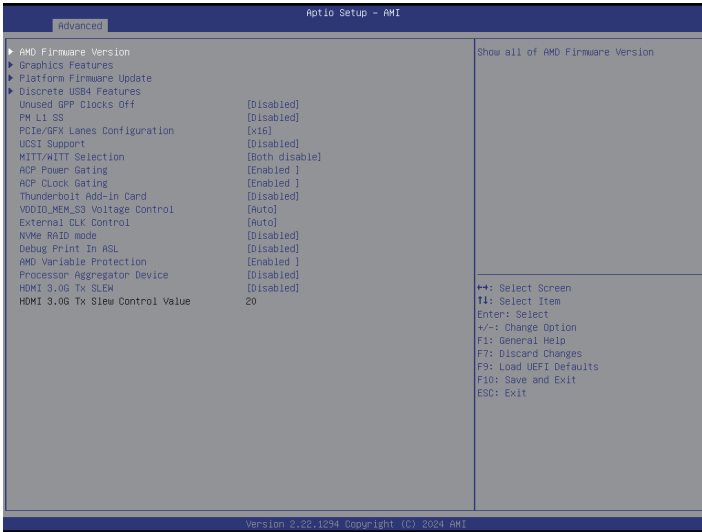

AMD Firmware Version

Show all of AMD Firmware Version.

Graphics Features

Graphics Features - HG, DGPU Features, BOMAC0.

Platform Firmware Update

Use this item to process Platform Firmware Update

Discrete USB4 Features

Discrete USB4 Features - PCIe resource, D3 support, Native USB4 support and so on.

Unused GPP Clocks Off

Turn Unused GPP Clocks Off.

Clock Power Management (CLKREQ#)

Enable or disable CLKREQ#.

PM L1 SS

Enable for PM L1 SS and ASPM L1 SS.

PCIe/GFX Lanes Configuration

Use this item to configure J10 Slot PCIe Lanes.

UCSI Support

Enable for UCSI (USB Type-C Connector System Software Interface).

MITT/WITT Selection

Use this item to configure MITT/WITT Selection

ACP Power Gating

Use this item to enable or disable ACP Power Gating.

ACP Lock Gating

Use this item to enable or disable ACP CLOCK Gating.

Thunderbolt Add-in Card

Enable Thunderbolt AR/TR Add-in Card Support.

Thunderbolt Host Chipset

Use this item to select Thunderbolt Host Card Chipset Name.

TR HR FPB Capability

Use this item to enable or disable Titan Ridge Host Card PCIe FPB Capability.

Thunderbolt Security Level

Use this item to select Thunderbolt Security Level.

Thunderbolt Force PWR

Enable Thunderbolt Force PWR.

Thunderbolt Boot From TB

Do Thunderbolt (Boot On) Command Before or After PCI Enumeration.

Thunderbolt Boot From USB

Do Thunderbolt (USB On) Command Before or After PCI Enumeration.

Thunderbolt Assign Resource

Assign Thunderbolt Resource Before or After PCI Enumeration.

Thunderbolt MMIO Resource

Use this item to select Thunderbolt PCIE MMIO Resource.

Thunderbolt in SLOT

Use this item to select Thunderbolt Slot.

Legacy/Native/RTD3

Use this item to select Thunderbolt Legacy/Native/RTD3 Mode.

Thunderbolt L1SS Support

Use this item to select Thunderbolt PCIE L1SS Support.

Thunderbolt Wake Up Command

Use this item to select Thunderbolt Wake Up Command.

VDDIO_MEM_S3 Voltage Control

Use this item to configure voltage control for VDDIO_MEM_S3 with Auto or Manual selections with Auto (1.1V by default) / Manual (Set voltage from 700mv~2688mv, step 2mv)

External CLK Control

Use the item to configure External CLK Control with Auto (100Mhz CGPLL generated by default) / eCLK0 (EXT_GPP0_SRC) or GPP1 (External input thru GPP1).



Switch APU clocks source mapping will get stuck immediately (post code: B0005A5A), manual press cold reset button to bypass the stuck.

NVMe RAID mode

Use this item to enable or disable NVMe RAID mode. Please setting the 'PCIe/GFX Lanes Configuration' item according to the RAID configuration.

Debug Print In ASL

Enable Debug Print In ASL.

AMD Variable Protection

Enable to protect some AMD specific variables for CBS, PBS and ADD. If locked, some utilities like RU that modify variable at runtime do not work.

Processor Aggregator Device

Enable or disable the Processor Aggregator Device.

Core Count Control

Enable or disable the Core Count Control.

Core Count SW_SCI_GPE_ID

Use this item to select Core Count SW_SCI_GPE_ID range:0~31, default:25.

HDMI 3.0G Tx SLEW

Enable or disable the HDMI 3.0G Tx SLEM.

HDMI 3.0G Tx Slew Control Value

Configure the HDMI 3.0G Tx Slew Control Value (0~255).

3.3.17 AMD Overclocking



The AMD Overclocking menu accesses options for configuring CPU frequency and voltage.

3.3.18 Inter(R) Ethernet Controller I210-LM

Configure Gigabit Ethernet device parameters.



Enter this item to view UEFI Driver, Device Name, Link Status and MAC Address information.

3.3.19 VLAN Configuration

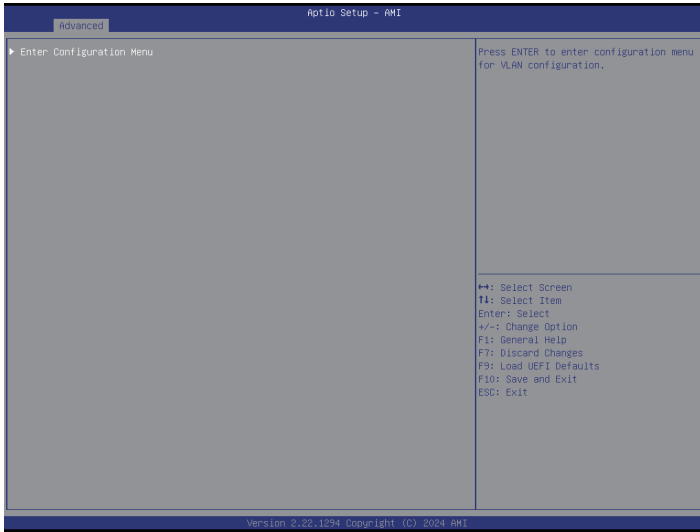

Enter Configuration Menu

Press [Enter] to enter the menu for VLAN configuration.

VLAN ID

Specifies the VLAN ID of new VLAN or existing VLAN, the valid value is 0~4094.

Priority

Specifies the 802.1Q Priority, the valid value is 0~7.

Add VLAN

Use this item to create a new VLAN or update existing VLAN.

Remove VLAN

Use this item to remove selected VLANS.

3.3.20 Instant Flash

Instant Flash is a UEFI flash utility embedded in Flash ROM. This convenient UEFI update tool allows user to update system UEFI without entering operating systems first like MS-DOS or Windows. Just save the new UEFI file to the USB flash drive, floppy disk or hard drive and launch this tool, then update the UEFI only in a few clicks without preparing an additional floppy diskette or other complicated flash utility. Please be noted that the USB flash drive or hard drive must use FAT32/16/12 file system. If executing Instant Flash utility, the utility will show the UEFI files and their respective information. Select the proper UEFI file to update the UEFI, and reboot the system after the UEFI update process is completed.

3.4 Security

In this section, set or change the supervisor/user password for the system. For the user password, also can to clear it.

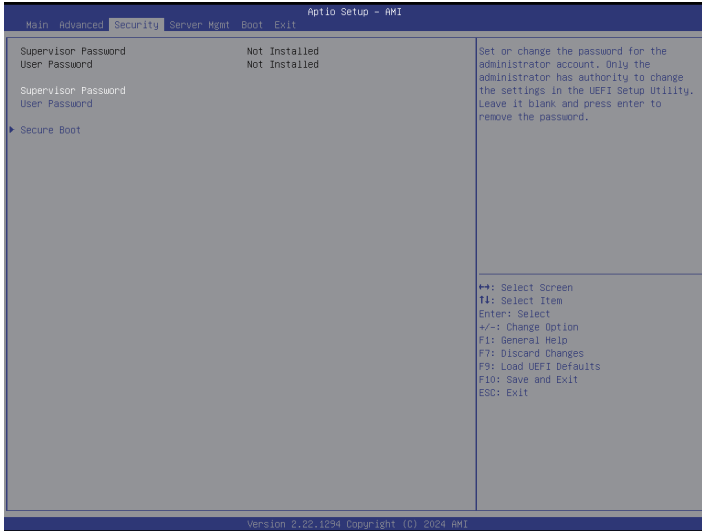

Supervisor Password

Set or change the password for the administrator account. Only the administrator has authority to change the settings in the UEFI Setup Utility. Leave it blank and press [Enter] to remove the password.

User Password

Set or change the password for the user account. Users are unable to change the settings in the UEFI Setup Utility. Leave it blank and press [Enter] to remove the password.

Secure Boot

Use this to Enable or disable Secure Boot Control. The default value is [Enabled]. Enable to support Windows Server 2012 R2 or later versions Secure Boot.

Secure Boot Mode

Secure Boot mode options: Standard or Custom. In Custom mode, Secure Boot Policy variables can be configured by a physically present user without full authentication.

Install Default Secure Boot Keys

Please install default secure boot keys if it's the first time using secure boot.

Clear Secure Boot Keys

Use this to clear the secure boot keys.

Expert Key Management

Enables expert users to modify Secure Boot Policy variables without variable authentication.

3.4.1 Install Default Secure Boot Keys

Please install default secure boot keys if it is the first time to use secure boot. Select Clear Secure Boot keys item to clear the assigned secure boot keys.

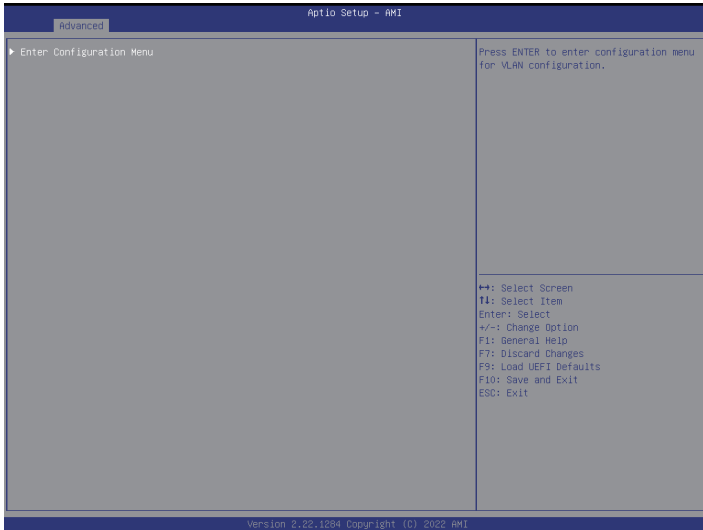

3.4.2 Expert Key Management

In this section, expert users can modify Secure Boot Policy variables without full authentication.



Factory Key Provision

Install factory default Secure Boot Keys after the platform reset and while the system is in Setup mode.

Install Default Secure Boot Keys

Please install default secure boot keys if it's the first time to use secure boot.

Clear Secure Boot Keys

Force System to Setup Mode - clear all Secure Boot Variables. Change takes effect after re-boot.

Enroll Ef Image

Allow the image to run in Secure Boot mode. Enroll SHA256 hash of the binary into Authorized Signature Database (db).

Export Secure Boot Variables

Copy NVRAM content of Secure Boot variables to files in a root folder on a file system device.

Platform Key (PK)

Enroll Factory Defaults or load certificates from a file:

1. Public Key Certificate in:

- a) EFI_SIGNATURE_LIST
- b) EFI_CERT_X509 (DER)
- c) EFI_CERT_RSA2048 (bin)
- d) EFI_CERT_SHAXXX

2. Authenticated UEFI Variable

3. EFI PE/COFF Image(SHA256)

Key Source: Factory, Modified, Mixed

Key Exchange Keys (KEK)

Enroll Factory Defaults or load certificates from a file:

1. Public Key Certificate in:

- a) EFI_SIGNATURE_LIST
- b) EFI_CERT_X509 (DER)
- c) EFI_CERT_RSA2048 (bin)
- d) EFI_CERT_SHAXXX

2. Authenticated UEFI Variable

3. EFI PE/COFF Image(SHA256)

Key Source: Factory, Modified, Mixed

Authorized Signatures (db)

Enroll Factory Defaults or load certificates from a file:

1. Public Key Certificate in:

- a) EFI_SIGNATURE_LIST

- b) EFI_CERT_X509 (DER)
 - c) EFI_CERT_RSA2048 (bin)
 - d) EFI_CERT_SHAXXX
2. Authenticated UEFI Variable
 3. EFI PE/COFF Image(SHA256)
- Key Source: Factory, Modified, Mixed

Forbidden Signatures (dbx)

Enroll Factory Defaults or load certificates from a file:

1. Public Key Certificate in:
 - a) EFI_SIGNATURE_LIST
 - b) EFI_CERT_X509 (DER)
 - c) EFI_CERT_RSA2048 (bin)
 - d) EFI_CERT_SHAXXX
 2. Authenticated UEFI Variable
 3. EFI PE/COFF Image(SHA256)
- Key Source: Factory, Modified, Mixed

Authorized TimeStamps (dbt)

Enroll Factory Defaults or load certificates from a file:

1. Public Key Certificate in:
 - a) EFI_SIGNATURE_LIST
 - b) EFI_CERT_X509 (DER)
 - c) EFI_CERT_RSA2048 (bin)
 - d) EFI_CERT_SHAXXX
 2. Authenticated UEFI Variable
 3. EFI PE/COFF Image(SHA256)
- Key Source: Factory, Modified, Mixed

OsRecovery Signatures (dbr)

Enroll Factory Defaults or load certificates from a file:

1. Public Key Certificate in:

- a) EFI_SIGNATURE_LIST
- b) EFI_CERT_X509 (DER)
- c) EFI_CERT_RSA2048 (bin)
- d) EFI_CERT_SHAXXX

2. Authenticated UEFI Variable

3. EFI PE/COFF Image(SHA256)

Key Source: Factory, Modified, Mixed

3.5 Server Mgmt

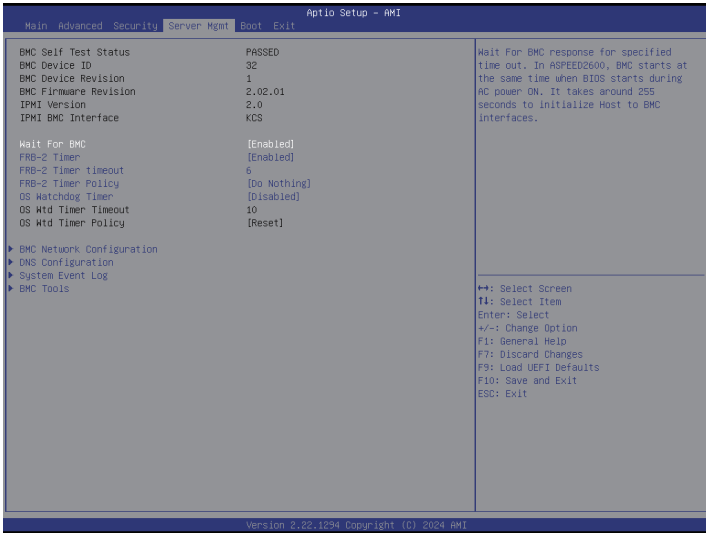

Wait For BMC

Wait For BMC response for specified time out. BMC starts at the same time when BIOS starts during AC power ON. It takes around 90 seconds to initialize Host to BMC interfaces.

FRB-2 Timer

Use this item to enable or disable FRB-2 timer (POST timer).

FRB-2 Timer Timeout

Enter value between 1 to 30 min for FRB-2 Timer Expiration.

FRB-2 Timer Policy

Use this item to configure how the system should respond if the FRB-2 Timer expires. Not available if FRB-2 Timer is disabled.

OS Watchdog Timer

If enabled, starts a BIOS timer which can only be shut off by Management Software after the OS loads. Helps determine that the OS successfully loaded or follows the OS Boot Watchdog Timer policy.

OS Wtd Timer Timeout

Enter value between 1 to 30 min for OS Boot Watchdog Timer Expiration. Not available if OS BootWatchdog Timer is disabled.

OS Wtd Timer Policy

Use this item to configure how the system should respond if the OS Watchdog Timer expires. Not available if OS Boot Watchdog Timer is disabled.

3.5.1 BMC Network Configuration

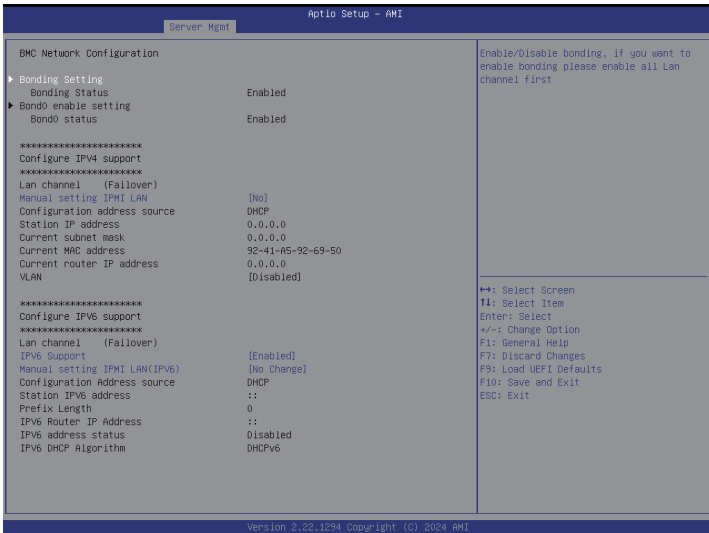

Bonding Setting

Use this item to enable or disable bonding. If want to enable bonding, please enable all Lan channels first.

Lan channel (Failover)

Manual Setting IPMI LAN

If [No] is selected, the IP address is assigned by DHCP. If using a static IP address, toggle to [Yes], and the changes take effect after the system reboots. The default value is [No].

Configuration Address Source

Select to configure BMC network parameters statically or dynamically(by BIOS or BMC). Configuration options: [Static] and [DHCP].

Static: Manually enter the IP Address, Subnet Mask and Gateway Address in the BIOS for BMC LAN channel configuration.

DHCP: IP address, Subnet Mask and Gateway Address are automatically assigned by the network's DHCP server.



When [DHCP] or [Static] is selected, do NOT modify the BMC network settings on the IPMI web page.



The default login information for the IPMI web interface is:

Username: admin

Password: admin

For more instructions on how to set up remote control environment and use the IPMI management platform, please refer to the IPMI Configuration User Guide or go to the Support website at: <http://www.asrockrack.com/support/faq.asp>

VLAN

Enable or disable Virtual Local Area Network.

If [Enabled] is selected, configure the items below.

VLAN ID: Select this item to configure the VLAN ID setting, the Maximum value is 4094 and the Minimum value is 1.

VLAN Priority: Select this item to configure the VLAN Priority setting, the Maximum value is 7 and the Minimum value is 0.

IPV6 Support

Enable or disable LAN1 IPV6 Support.

Manual Setting IPMI LAN(IPV6)

Select to configure LAN channel parameters statically or dynamically (by BIOS or BMC).

Unspecified option will not modify any BMC network parameters during BIOS phase.

3.5.2 DNS Configuration

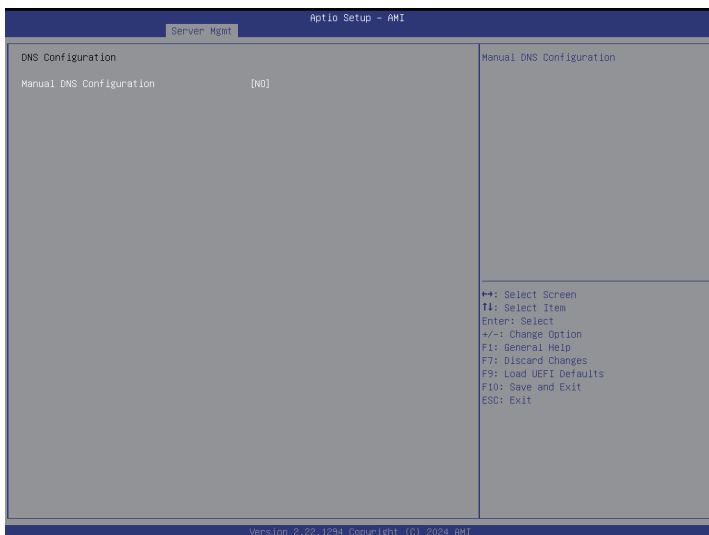

Manual DNS Configuration

Select this item to manual configure DNS.

If [YES] is selected, configure the items below.

DNS Service

Use this item to enable or disable DNS Service Configuration.

Host Name Settings

Use this item to automatic or manual Host Name Settings.

Bond Register BMC

Use this item to enable or disable Bond Register BMC.

Bond Register Method

Use this item to configure Bond Register Method with Nsupdate or DHCP client FQDN/Hostname..

Domain Setting

This item supports Manual, Bond0_v4 and Bond0_v6 Domain Settings.

Domain Name Server Setting

This item supports Manual and Bond0 DNS Server Settings.

IP Priority

This item supports IPV4 and IPV6 IP Priority.

3.5.3 System Event Log

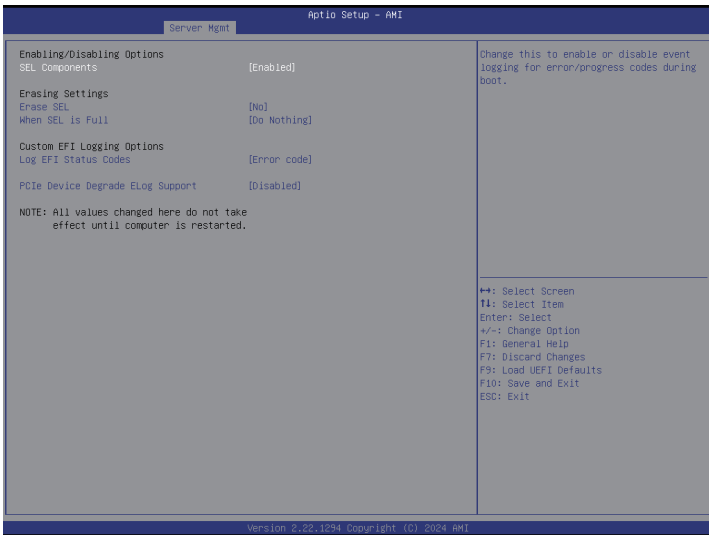

SEL Components

Change this to enable or disable event logging for error/progress codes during boot.

Erase SEL

Use this to choose options for erasing SEL.

When SEL is Full

Use this to choose options for reactions to a full SEL.

Log EFI Status Codes

Use this item to disable the logging of EFI Status Codes or log only error code or only progress code or both.

PCIe Device Degrade ELog Support

Use this item to enable or disable PCIe Device Degrade Error Logging Support.

3.5.4 BMC Tools

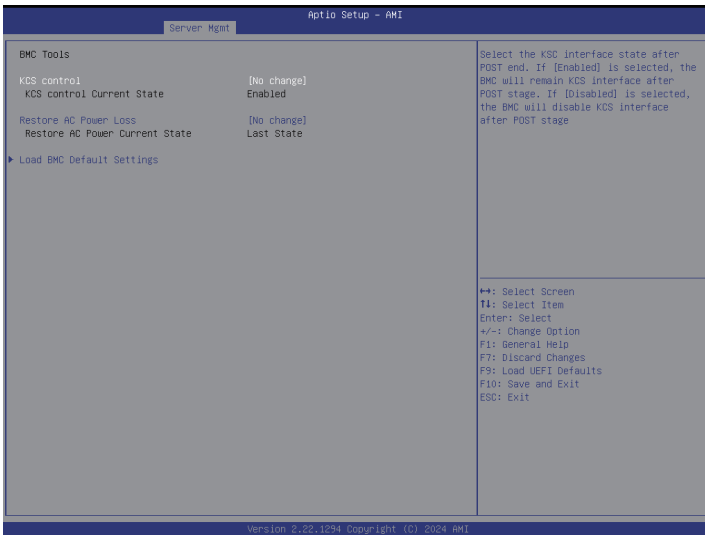

KCS Control

Select this KCS interface state after POST end. If [Enabled] is selected, the BMC will remain KCS interface after POST stage. If [Disabled] is selected, the BMC will disable KCS interface after POST stage.

Restore AC Power Loss

Select the power state after a power failure. If [Power Off] is selected, the power will remain off when the power recovers. If [Power On] is selected, the system will start to boot up when the power recovers.

Load BMC Default Settings

Use this item to Load BMC Default Settings

3.6 Boot Screen

In this section, it will display the available devices on the system for user to configure the boot settings and the boot priority.

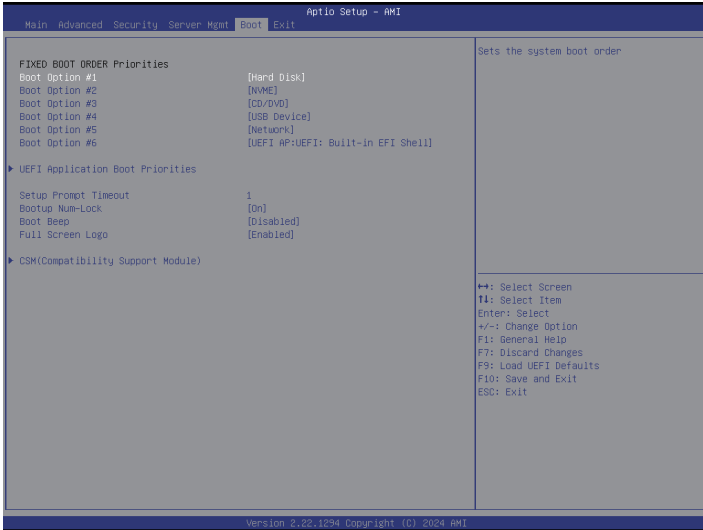

Boot Option #1~#6

Use this item to set the system boot order.

UEFI Application Boot Priorities

Use this item to specifies the Boot Device Priority sequence from available UEFI Application.

Setup Prompt Timeout

Configure the number of seconds to wait for the UEFI setup utility.

Bootup Num-Lock

Select whether Num Lock should be turned on or off when the system boots up.

Boot Beep

Select whether the Boot Beep should be turned on or off when the system boots up. Please note that a buzzer is needed.

Full Screen Logo

Enable to display the boot logo or disable to show normal POST messages.

3.6.1 CSM Parameters

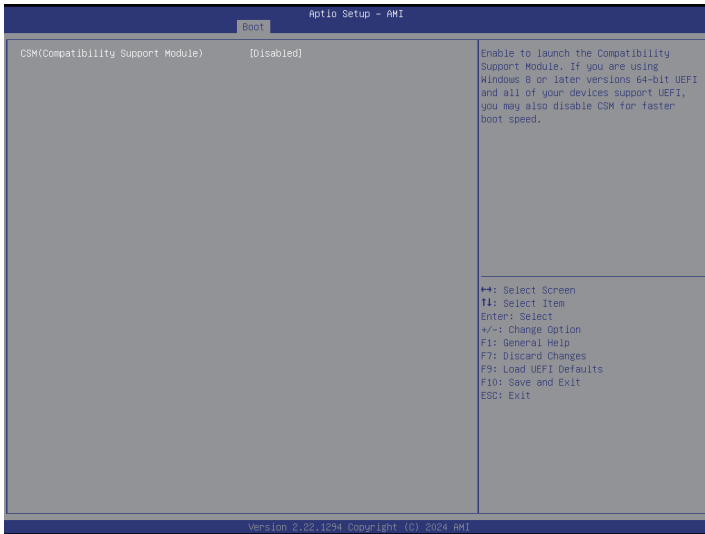

CSM (Compatibility Support Module)

Enable to launch the Compatibility Support Module. Please do not disable unless running a WHCK test. If using Windows 8 or later versions 64-bit UEFI and all of the devices support UEFI, it may also disable CSM for faster boot speed.

Launch PXE OpROM Policy

Select UEFI only to run those that support UEFI option ROM only. Select Legacy only to run those that support legacy option ROM only. Select Do not launch to not execute both legacy and UEFI option ROM.

Launch Storage OpROM Policy

Select UEFI only to run those that support UEFI option ROM only. Select Legacy only to run those that support legacy option ROM only. Select Do not launch to not execute both legacy and UEFI option ROM.

Launch Video OpROM Policy

Select UEFI only to run those that support UEFI option ROM only. Select Legacy only to run those that support legacy option ROM only. Select Do not launch to not execute both legacy and UEFI option ROM.

3.7 Exit Screen

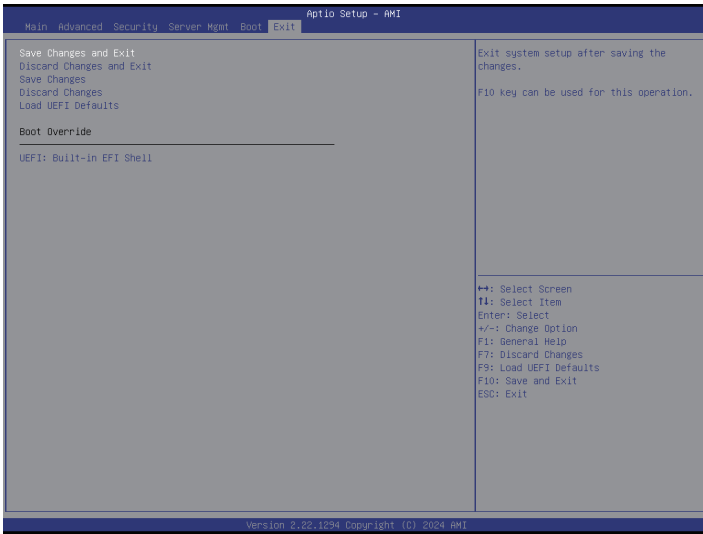

Save Changes and Exit

When selecting this option, the following message “Save configuration changes and exit setup?” will pop-out. Press <F10> key or select [Yes] to save the changes and exit the UEFI SETUP UTILITY.

Discard Changes and Exit

When selecting this option, the following message “Discard changes and exit setup?” will pop-out. Press <ESC> key or select [Yes] to exit the UEFI SETUP UTILITY without saving any changes.

Save Changes

When selecting this option, the following message “Save changes?” will pop-out. Press <F7> key or select [Yes] to save all changes.

Discard Changes

When selecting this option, the following message “Discard changes?” will pop-out. Press <F7> key or select [Yes] to discard all changes.

Load UEFI Defaults

Load UEFI default values for all the setup questions. F9 key can be used for this operation.

Chapter 4 Software Support

After all the hardware has been installed, it suggests user go to the official website at <http://www.ASRockRack.com> and make sure if there are any new updates of the BIOS / BMC firmware for the motherboard.

4.1 Download and Install Operating System

This motherboard supports various Microsoft® Windows® Server / Linux compliant operating systems. Please download the operating system from the OS manufacturer. Please refer to the OS documentation for more instructions.

4.2 Download and Install Software Drivers

This motherboard supports various Microsoft® Windows® compliant drivers. Please download the required drivers from our website at <http://www.ASRockRack.com>.

To download necessary drivers, go to the product page, click on the "Download" tab, choose the operating system that is used, and then download the using driver.

4.3 Contact Information

Contact ASRock Rack or want to know more about ASRock Rack, welcome to visit ASRock Rack's website at <http://www.ASRockRack.com>; or contact the dealer for further information.

Chapter 5 Troubleshooting

5.1 Troubleshooting Procedures

Follow the procedures below to troubleshoot the system.



Always unplug the power cord before adding, removing or changing any hardware components. Failure to do so may cause physical injuries and motherboard damages.

1. Disconnect the power cable and check whether the PWR LED is off.
2. Unplug all cables, connectors and remove all add-on cards from the motherboard. Make sure that the jumpers are set to default settings.
3. Confirm that there are no short circuits between the motherboard and the chassis.
4. Install a CPU and fan on the motherboard, then connect the chassis speaker and power LED.

If there is no power...

1. Confirm that there are no short circuits between the motherboard and the chassis.
2. Make sure that the jumpers are set to default settings.
3. Check the settings of the 115V/230V switch on the power supply.
4. Verify if the battery on the motherboard provides ~3VDC. Install a new battery if it does not.

If there is no video...

1. Try replugging the monitor cables and power cord.
2. Check for memory errors.

If there are memory errors...

1. Verify that the DIMM modules are properly seated in the slots.
2. Use recommended ECC/non-ECC UDIMM modules.
3. If having to install more than one DIMM modules, they should be identical with the same brand, speed, size and chip-type.
4. Try inserting different DIMM modules into different slots to identify faulty ones.
5. Check the settings of the 115V/230V switch on the power supply.

Unable to save system setup configurations...

1. Verify if the battery on the motherboard provides ~3VDC. Install a new battery if it does not.
2. Confirm whether the power supply provides adequate and stable power.

Other problems...

1. Try searching keywords related to the problem on ASRock Rack's FAQ page:
<http://www.asrockrack.com/support>

5.2 Technical Support Procedures

If having tried the troubleshooting procedures mentioned above and the problems are still unsolved, please contact ASRock Rack's technical support with the following information:

1. Contact information
2. Model name, BIOS version and problem type.
3. System configuration.
4. Problem description.

Contact ASRock Rack's technical support at:

<http://www.asrockrack.com/support/tsd.asp>

5.3 Returning Merchandise for Service

For warranty service, the receipt or a copy of the invoice marked with the date of purchase is required. By calling the vendor or going to the RMA website (<http://event.asrockrack.com/tsd.asp>) it may obtain a Returned Merchandise Authorization (RMA) number.

The RMA number should be displayed on the outside of the shipping carton which is mailed prepaid or hand-carried when returning the motherboard to the manufacturer. Shipping and handling charges will be applied for all orders that must be mailed when service is complete.

This warranty does not cover damages incurred in shipping or from failure due to alteration, misuse, abuse or improper maintenance of products.

Contact the distributor first for any product related problems during the warranty period.

Contact Information

Contact ASRock Rack or want to know more about ASRock Rack, you're welcome to visit ASRock Rack's website at <http://www.asrockrack.com>; or contact the dealer for further information. For technical questions, please submit a support request form at <https://event.asrockrack.com/tsd.asp>

ASRock Rack Incorporation

e-mail: ASRockRack_sales@asrockrack.com

ASRock Rack Europe B.V.

Bijsterhuizen 11-11

6546 AR Nijmegen

The Netherlands

Phone: +31-24-345-44-33

ASRock Rack America Inc.

4331 Eucalyptus Ave., Chino, CA 91710 U.S.A.

Phone: +1-909-590-8308

Fax: +1-909-590-1026