



OPEN

Industry Standard, Flexible Architecture

GREEN

Less Heat, Less Power Consumption

STABLE

Robust Design, Quality Parts

Stable and
Reliable Solution

Server/Workstation

Motherboard

EPC612D8TA-TB

EPC612D8TA

EPC612D8T



User Manual

English



Version 1.0

Published August 2014

Copyright©2014 ASRock Rack Inc. All rights reserved.

Copyright Notice:

No part of this documentation may be reproduced, transcribed, transmitted, or translated in any language, in any form or by any means, except duplication of documentation by the purchaser for backup purpose, without written consent of ASRock Rack Inc.

Products and corporate names appearing in this documentation may or may not be registered trademarks or copyrights of their respective companies, and are used only for identification or explanation and to the owners' benefit, without intent to infringe.

Disclaimer:

Specifications and information contained in this documentation are furnished for informational use only and subject to change without notice, and should not be constructed as a commitment by ASRock Rack. ASRock Rack assumes no responsibility for any errors or omissions that may appear in this documentation.

With respect to the contents of this documentation, ASRock Rack does not provide warranty of any kind, either expressed or implied, including but not limited to the implied warranties or conditions of merchantability or fitness for a particular purpose.

In no event shall ASRock Rack, its directors, officers, employees, or agents be liable for any indirect, special, incidental, or consequential damages (including damages for loss of profits, loss of business, loss of data, interruption of business and the like), even if ASRock Rack has been advised of the possibility of such damages arising from any defect or error in the documentation or product.



This device complies with Part 15 of the FCC Rules. Operation is subject to the following two conditions:

- (1) this device may not cause harmful interference, and
- (2) this device must accept any interference received, including interference that may cause undesired operation.

CALIFORNIA, USA ONLY

The Lithium battery adopted on this motherboard contains Perchlorate, a toxic substance controlled in Perchlorate Best Management Practices (BMP) regulations passed by the California Legislature. When you discard the Lithium battery in California, USA, please follow the related regulations in advance.

“Perchlorate Material-special handling may apply, see www.dtsc.ca.gov/hazardouswaste/perchlorate”

ASRock Rack's Website: www.ASRockRack.com

Contact Information

If you need to contact ASRock Rack or want to know more about ASRock Rack, you're welcome to visit ASRock Rack's website at www.ASRockRack.com; or you may contact your dealer for further information.

ASRock Rack Incorporation

6F., No.37, Sec. 2, Jhongyang S. Rd., Beitou District,

Taipei City 112, Taiwan (R.O.C.)

Contents

Chapter 1 Introduction	1
1.1 Package Contents	1
1.2 Specifications	2
1.3 Unique Features	6
1.4 Motherboard Layout	7
1.5 I/O Panel	14
1.6 Block Diagram	17
Chapter 2 Installation	20
2.1 Screw Holes	20
2.2 Pre-installation Precautions	20
2.3 Installing the CPU	21
2.4 Installing the CPU Fan and Heatsink	24
2.5 Installation of Memory Modules (DIMM)	25
2.6 Expansion Slots (PCI and PCI Express Slots)	27
2.7 Jumper Setup	28
2.8 Onboard Headers and Connectors	31
2.9 Dr. Debug	39
2.10 Driver Installation Guide	40
2.11 Dual LAN and Teaming Operation Guide	42
2.12 M.2_SSD (NGFF) Module Installation Guide	43
Chapter 3 UEFI Setup Utility	46
3.1 Introduction	46
3.1.1 UEFI Menu Bar	46

3.1.2	Navigation Keys	47
3.2	Main Screen	48
3.3	Advanced Screen	49
3.3.1	CPU Configuration	50
3.3.2	DRAM Configuration	52
3.3.3	ACPI Configuration	53
3.3.4	Configure Super IO Settings	55
3.3.5	Serial Port Console Redirection	56
3.3.6	USB Configuration	58
3.3.7	Chipset Configuration	59
3.3.8	Storage Configuration	62
3.3.9	H/W Monitor Screen	66
3.3.10	Intel ME Configuration	68
3.3.11	Easy RAID Installer	69
3.3.12	Instant Flash	70
3.4	Server Mgmt (Server Management)	71
3.5	Security Screen	73
3.6	Boot Screen	74
3.7	Event Logs	76
3.8	Exit Screen	78
	Chapter 4 Software Support	79
4.1	Install Operating System	79
4.2	Support CD Information	79
4.2.1	Running The Support CD	79

4.2.2 Drivers Menu	79
4.2.3 Utilities Menu	79
4.2.4 Contact Information	79
Chapter 5 Troubleshooting	80
5.1 Troubleshooting Procedures	80
5.2 Technical Support Procedures	82
5.3 Returning Merchandise for Service	82
Chapter 6: Net Framework Installation Guide	83
6.1 Installing .Net Framework 3.5.1 (For Server 2008 R2)	83

Chapter 1 Introduction

Thank you for purchasing ASRock Rack **EPC612D8T Series** motherboard, a reliable motherboard produced under ASRock Rack's consistently stringent quality control. It delivers excellent performance with robust design conforming to ASRock Rack's commitment to quality and endurance.

In this manual, chapter 1 and 2 contains introduction of the motherboard and step-by-step guide to the hardware installation. Chapter 3 and 4 contains the configuration guide to BIOS setup and information of the Support CD.



Because the motherboard specifications and the BIOS software might be updated, the content of this manual will be subject to change without notice. In case any modifications of this manual occur, the updated version will be available on ASRock Rack website without further notice. You may find the latest memory and CPU support lists on ASRock Rack website as well. ASRock Rack's Website: www.ASRockRack.com

*If you require technical support related to this motherboard, please visit our website for specific information about the model you are using.
<http://www.asrockrack.com/support/>*

1.1 Package Contents

- ASRock Rack EPC612D8T Series Motherboard
(ATX Form Factor: 12.0-in x 9.6-in, 30.5 cm x 24.4 cm)
- Support CD
- User Manual
- 4 x SATA3 Cables (50cm)
- 2 x SATA3 Cables (60cm)
- 1 x I/O Shield



If any items are missing or appear damaged, contact your authorized dealer.

1.2 Specifications

EPC612D8TA / EPC612D8TA-TB / EPC612D8T	
MB Physical Status	
Form Factor	ATX
Dimension	12" x 9.6" (30.5 cm x 24.4 cm)
Processor System	
CPU	Intel® Xeon processor E5-1600/2600 v3 series
Socket	Single Socket LGA 2011 R3
Chipset	Intel® C612
System Memory	
Capacity	8 DIMM slots
Type	- Quad Channel memory technology (see Caution 3) - Supports DDR3 1866/1600 ECC UDIMM / RDIMM
Voltage	1.35V & 1.5V
DIMM Sizes	UDIMM: 4GB, 2GB RDIMM: 4GB, 2GB
Expansion Slot (Slot 7 is the closest to the CPU)	
Slot 7	ME x16, EE x16 (x16/x0 or x8/x8 with slot 5)
Slot 6	ME x8, EE x8 (x8 if slot 4 mini PCIe is disabled)
Slot 5	ME x16, EE x8
Slot 4	mini PCIe x4 to support M.2 (Full and Half size support) <i>*The M.2 slot shares lanes with PCIe Slot 6.</i>
Slot 3	ME x16, EE x16 (x16/x0 or x8/x8 with slot 1)
Slot 2	N/A
Slot 1	ME x16, EE x8
Storage	
SATA	C612: 10 x SATA3 6Gb/s (1x SATA DOM)
Controller	
Additional SATA Controller	Marvell 9172: 2 x SATA3 6Gbps
Ethernet	
Interface	1000 /100 /10 Mbps
LAN Controller	2 x RJ45 by Intel® i210 + Intel® i217 1 x RJ45 Dedicated IPMI LAN port - Supports Wake-On-LAN - Supports Energy Efficient Ethernet 802.3az - Supports Dual LAN with Teaming function - Supports PXE

Management	
BMC Controller	ASPEED AST2400
IPMI Dedicated GLAN	- 1 x Realtek RTL8211E for dedicated management GLAN
Features	- Watch Dog - NMI
Graphics	
Controller	ASPEED AST2400
VRAM	DDR3 16MB
Audio	
Audio code	EPC612D8TA-TB / EPC612D8TA: Realtek ALC1150 EPC612D8T: N/A
Rear Panel I/O	
VGA Port	1 x D-Sub
USB 2.0 Port	2
USB 3.0 Port	2
Lan Port	- 2 + 1 (IPMI) Lan port (RJ45) - LAN Ports with LED (ACT/LINK LED and SPEED LED)
Serial Port	1 (COM1)
ThunderBolt	EPC612D8TA-TB: 1 with DP_IN <i>*The onboard Thunderbolt port is only supported on Windows 8.1 / 8 / 7.</i> EPC612D8TA / EPC612D8T: N/A
Audio Jack	EPC612D8TA-TB / EPC612D8TA: 3 Jack EPC612D8T: N/A
Internal Connector	
Auxiliary Panel Header	1 (include chassis intrusion , location button & LED , front LAN LED , system fault LED)
TPM Header	1
IPMB Header	1
Buzzer	1
Fan Header	1x CPU Fan, 4x system Fan (4-pin)
ATX Power	1 (24-pin) + 1 (8-pin)
USB 3.0 Header	1 (support 2 USB 3.0)
USB 2.0 Header	1 (support 2 USB 2.0)
Type A USB 2.0 Port	1
Front Panel	1

4 pin 5V box Connector	1
System BIOS	
BIOS Type	128Mb AMI UEFI Legal BIOS
BIOS Features	<ul style="list-style-type: none"> - Plug and Play (PnP) - ACPI 2.0 Compliance Wake Up Events - SMBIOS 2.8 Support - ASRock Rack Instant Flash
Hardware Monitor	
Temperature	<ul style="list-style-type: none"> - CPU Temperature Sensing - System Temperature Sensing
Fan	<ul style="list-style-type: none"> - CPU/Rear/Front Fan Tachometer - CPU Quiet Fan (Allow Chassis Fan Speed Auto-Adjust by CPU Temperature) - CPU/Rear/Front Fan Multi-Speed Control
Voltage	Voltage Monitoring: +12V, +5V, +3.3V, CPU Vcore, DRAM, 1.05V_PCH, +BAT, 3VSB, 5VSB
Support OS	
OS	<p>Microsoft® Windows®</p> <ul style="list-style-type: none"> - Windows® 7 (32 / 64 bit) - Windows® 8 (32 / 64 bit) - Windows® 8.1 (32 / 64 bit) - Server 2008 R2 SP1 (64 bit) - Server 2012 (64 bit) - Server 2012 R2 (64 bit) <p>Linux®</p> <ul style="list-style-type: none"> - RedHat Enterprise Linux Server 5.10/6.5 (32 / 64 bit) - CentOS 5.10 / 6.5 (32 / 64 bit) - SUSE Enterprise Linux Server 11 SP3 (32 / 64 bit) - FreeBSD 9.2 (32 / 64 bit) - Fedora core 19 (64 bit) - Ubuntu 12.04.2 (64 bit) / 12.10 (64 bit) <p>Virtual</p> <ul style="list-style-type: none"> - VMWare® ESXi 5.5 (<i>not supported for Marvell 9172</i>)
Environment	
Temperature	Operation temperature: 10°C ~ 35°C / Non operation temperature: -40°C ~ 70°C



This motherboard supports Wake from on Board LAN. To use this function, please make sure that the "Wake on Magic Packet from power off state" is enabled in Device Manager > Intel® Ethernet Connection > Power Management. And the "PCI Devices Power On" is enabled in UEFI SETUP UTILITY > Advanced > ACPI Configuration. After that, onboard LAN1&2 can wake up S5 under OS.



If you install Intel® LAN utility, Marvell SATA utility or Realtek HD audio driver, this motherboard may fail Windows® Hardware Quality Lab (WHQL) certification tests. If you install the drivers only, it will pass the WHQL tests.



- 1. About the setting of "Hyper Threading Technology", please check page 55.*
- 2. Due to Intel® CPU spec definition, please install the memory modules on DDR3_A1, DDR3_B1, DDR3_C1 and DDR3_D1 for the first priority. If above four DDR3 DIMM slots are fully installed, and you want to use more than four memory modules, please install the other memory modules from left to right (from DDR3_A2, DDR3_B2, DDR3_D2 to DDR3_C2.)*
- 3. Before you implement Quad Channel Memory Technology, make sure to read the installation guide of memory modules on page 25 for proper installation.*

1.3 Unique Features

ASRock Rack Instant Flash is a BIOS flash utility embedded in Flash ROM. This convenient BIOS update tool allows you to update system BIOS without entering operating systems first like MS-DOS or Windows. With this utility, you can press the <F6> key during the POST or the <F2> key to enter into the BIOS setup menu to access ASRock Rack Instant Flash. Just launch this tool and save the new BIOS file to your USB flash drive, floppy disk or hard drive, then you can update your BIOS only in a few clicks without preparing an additional floppy diskette or other complicated flash utility. Please be noted that the USB flash drive or hard drive must use FAT32/16/12 file system.

1.4 Motherboard Layout

EPC612D8TA-TB

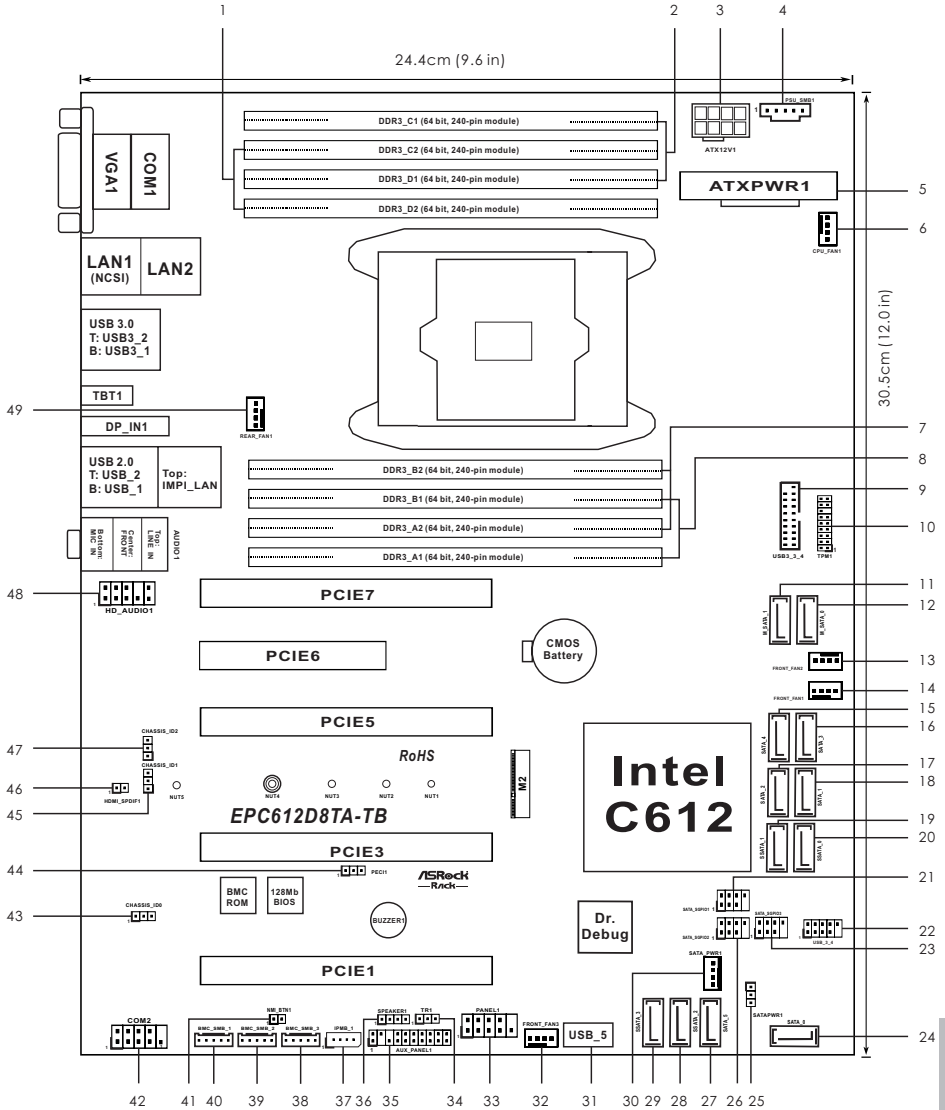

EPC612D8TA

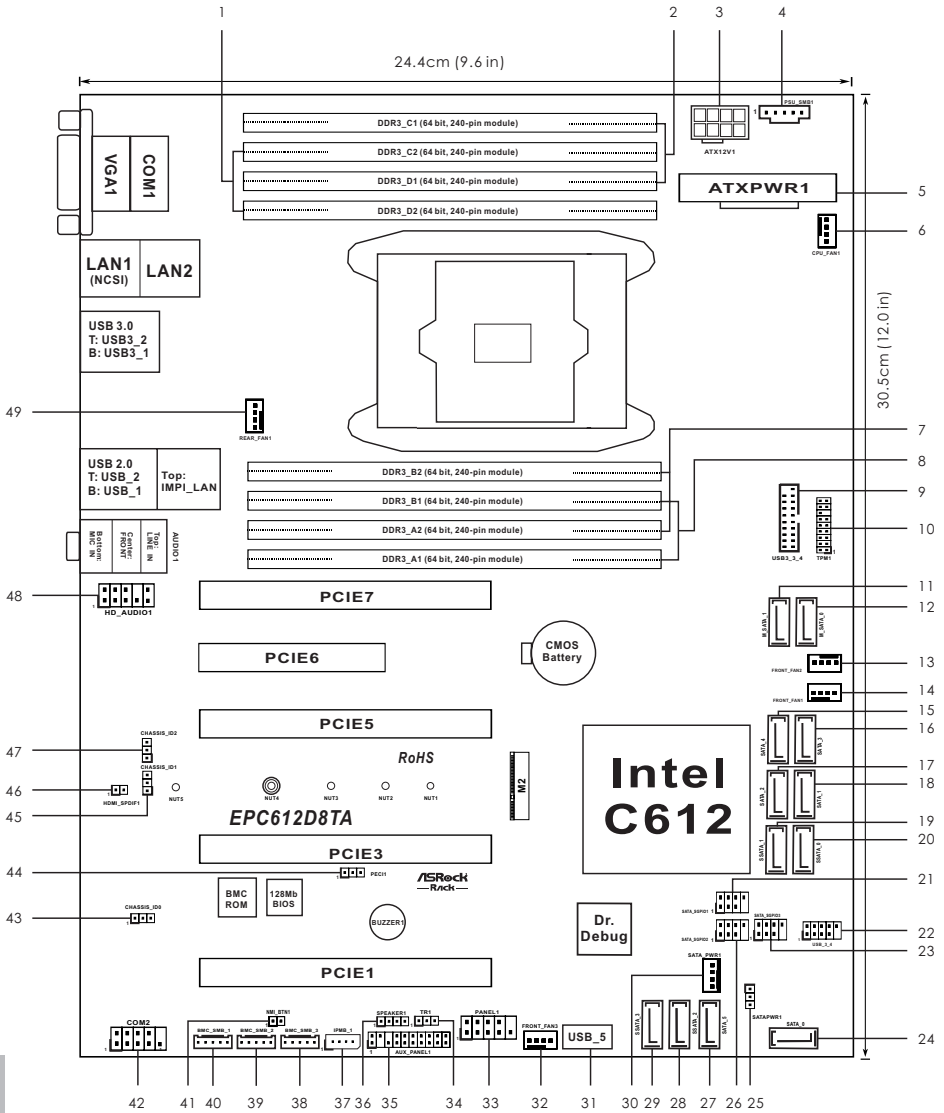

No.	Description
1	2 x 240-pin DDR3 DIMM Slots (DDR3_C2, DDR3_D2, White)
2	2 x 240-pin DDR3 DIMM Slots (DDR3_C1, DDR3_D1, Blue)
3	ATX 12V Power Connector (ATX12V1)
4	PSU SMBus (PSU_SMB1)
5	ATX Power Connector (ATXPWR1)
6	CPU Fan Connector (CPU_FAN1)
7	2 x 240-pin DDR3 DIMM Slots (DDR3_A2, DDR3_B2, White)
8	2 x 240-pin DDR3 DIMM Slots (DDR3_A1, DDR3_B1, Blue)
9	USB 3.0 Header (USB_3_4)
10	TPM Header (TPM1)
11	SATA3 Connector (M_SATA_1), White
12	SATA3 Connector (M_SATA_0), White
13	Front Fan Connector (FRONT_FAN2)
14	Front Fan Connector (FRONT_FAN1)
15	SATA3 Connector (SATA_4), White
16	SATA3 Connector (SATA_3), White
17	SATA3 Connector (SATA_2), White
18	SATA3 Connector (SATA_1), White
19	SATA3 Connector (SSATA_1), White
20	SATA3 Connector (SSATA_0), White
21	SATA SGPIO Connector (SATA_SGPIO1)
22	USB 2.0 Header (USB_3_4)
23	SATA SGPIO Connector (SATA_SGPIO3)
24	SATA3 DOM Connector (SATA_0), Red
25	SATA DOM Power Jumper (SATAPWR1)
26	SATA SGPIO Connector (SATA_SGPIO2)
27	SATA3 Connector (SATA_5), White
28	SATA3 Connector (SSATA_2), White (Marvell 9172)
29	SATA3 Connector (SSATA_3), White (Marvell 9172)
30	SATA DOM Power Header (SATA_PWR1)
31	Vertical Type A USB 2.0 (USB_5)
32	Front Fan Connector (FRONT_FAN3)
33	System Panel Header (PANEL1)

No.	Description
34	Thermal Sensor header (TR1)
35	Auxiliary Panel Header (AUX_PANEL1)
36	Speaker Header (SPEAKER1)
37	Intelligent Platform Management Bus header (IPMB_1)
38	BMC SMBus Header (BMC_SMB_3)
39	BMC SMBus Header (BMC_SMB_2)
40	BMC SMBus Header (BMC_SMB_1)
41	Non Maskable Interrupt Button (NMI_BTN1)
42	COM Port Header (COM2)
43	Chassis ID0 Jumper (Chassis ID0)
44	CPU PECI Jumper (PECI1)
45	Chassis ID0 Jumper (Chassis ID1)
46	HDMI_SPDIF Header (HDMI_SPDIF1)
47	Chassis ID0 Jumper (Chassis ID2)
48	Front Panel Audio Header (HD_AUDIO1)
49	Rear Fan Connector (REAR_FAN1)

**The onboard Thunderbolt port is only supported on Windows 8.1 / 8 / 7.*

No.	Description
1	2 x 240-pin DDR3 DIMM Slots (DDR3_C2, DDR3_D2, White)
2	2 x 240-pin DDR3 DIMM Slots (DDR3_C1, DDR3_D1, Blue)
3	ATX 12V Power Connector (ATX12V1)
4	PSU SMBus (PSU_SMB1)
5	ATX Power Connector (ATXPWR1)
6	CPU Fan Connector (CPU_FAN1)
7	2 x 240-pin DDR3 DIMM Slots (DDR3_A2, DDR3_B2, White)
8	2 x 240-pin DDR3 DIMM Slots (DDR3_A1, DDR3_B1, Blue)
9	USB 3.0 Header (USB3_3_4)
10	TPM Header (TPM1)
11	SATA3 Connector (M_SATA_1), White
12	SATA3 Connector (M_SATA_0), White
13	Front Fan Connector (FRONT_FAN2)
14	Front Fan Connector (FRONT_FAN1)
15	SATA3 Connector (SATA_4), White
16	SATA3 Connector (SATA_3), White
17	SATA3 Connector (SATA_2), White
18	SATA3 Connector (SATA_1), White
19	SATA3 Connector (SSATA_1), White
20	SATA3 Connector (SSATA_0), White
21	SATA SGPIO Connector (SATA_SGPIO1)
22	USB 2.0 Header (USB_3_4)
23	SATA SGPIO Connector (SATA_SGPIO3)
24	SATA3 DOM Connector (SATA_0), Red
25	SATA DOM Power Jumper (SATAPWR1)
26	SATA SGPIO Connector (SATA_SGPIO2)
27	SATA3 Connector (SATA_5), White
28	SATA3 Connector (SSATA_2), White (Marvell 9172)
29	SATA3 Connector (SSATA_3), White (Marvell 9172)
30	SATA DOM Power Header (SATA_PWR1)
31	Vertical Type A USB 2.0 (USB_5)
32	Front Fan Connector (FRONT_FAN3)
33	System Panel Header (PANEL1)

No.	Description
34	Thermal Sensor header (TR1)
35	Auxiliary Panel Header (AUX_PANEL1)
36	Speaker Header (SPEAKER1)
37	Intelligent Platform Management Bus header (IPMB_1)
38	BMC SMBus Header (BMC_SMB_3)
39	BMC SMBus Header (BMC_SMB_2)
40	BMC SMBus Header (BMC_SMB_1)
41	Non Maskable Interrupt Button (NMI_BTN1)
42	COM Port Header (COM2)
43	Chassis ID0 Jumper (Chassis ID0)
44	CPU PECI Jumper (PECI1)
45	Chassis ID0 Jumper (Chassis ID1)
46	Chassis ID0 Jumper (Chassis ID2)
47	Rear Fan Connector (REAR_FAN1)

1.5 I/O Panel

EPC612D8TA-TB

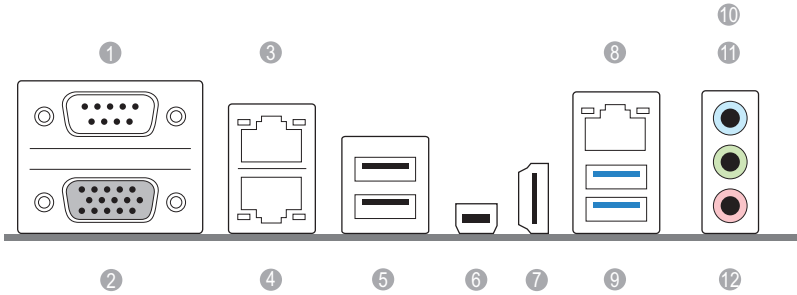

No.	Description	No.	Description
1	Serial Port (COM1)	7	Display Port Input (DP_IN1)
2	VGA Port (VGA1)	8	LAN RJ-45 Port (IPMI_LAN)**
3	LAN RJ-45 Port (LAN2)*	9	USB 3.0 Ports (USB3_1-2)
4	LAN RJ-45 Port (LAN1)* (NCSI)	10	Front Speaker (Lime)
5	USB 2.0 Ports (USB_1_2)	11	Microphone (Pink)
6	Thunderbolt Port (TBT1)	12	Line In (Light Blue)

*The onboard Thunderbolt port is only supported on Windows 8.1 / 8 / 7.

EPC612D8TA

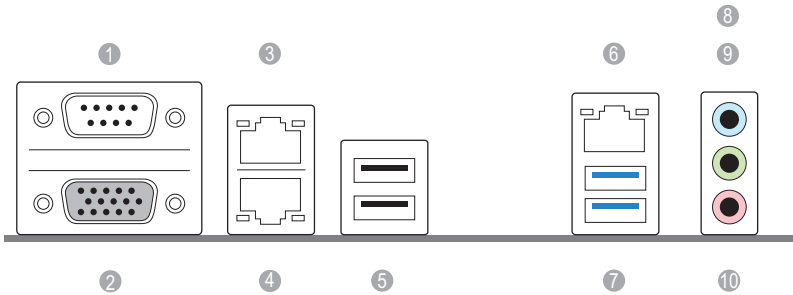

No.	Description	No.	Description
1	Serial Port (COM1)	6	LAN RJ-45 Port (IPMI_LAN)**
2	VGA Port (VGA1)	7	USB 3.0 Ports (USB3_1-2)
3	LAN RJ-45 Port (LAN2)*	8	Front Speaker (Lime)
4	LAN RJ-45 Port (LAN1)* (NCSI)	9	Microphone (Pink)
5	USB 2.0 Ports (USB_1_2)	10	Line In (Light Blue)

EPC612D8T



No.	Description	No.	Description
1	Serial Port (COM1)	5	USB 2.0 Ports (USB_1_2)
2	VGA Port (VGA1)	6	LAN RJ-45 Port (IPMI_LAN)**
3	LAN RJ-45 Port (LAN2)*	7	USB 3.0 Ports (USB3_1-2)
4	LAN RJ-45 Port (LAN1)* (NCSI)		

LAN Port LED Indications

*There are two LED next to the LAN port. Please refer to the table below for the LAN port LED indications.

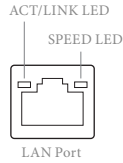

Dedicated IPMI LAN Port LED Indications

Activity / Link LED		Speed LED	
Status	Description	Status	Description
Off	No Link	Off	10Mbps connection
Blinking	Data Activity (100Mbps)	Orange	100Mbps connection
On	Link	Green	1Gbps connection

**There are two LEDs on each LAN port. Please refer to the table below for the LAN port LED indications.

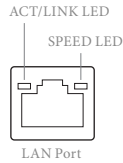

LAN Port (LAN1, LAN2) LED Indications

Activity / Link LED		Speed LED	
Status	Description	Status	Description
Off	No Link	Off	10Mbps connection
Blinking	Data Activity	Orange	100Mbps connection
On	Link	Green	1Gbps connection

1.6 Block Diagram

EPC612D8TA-TB

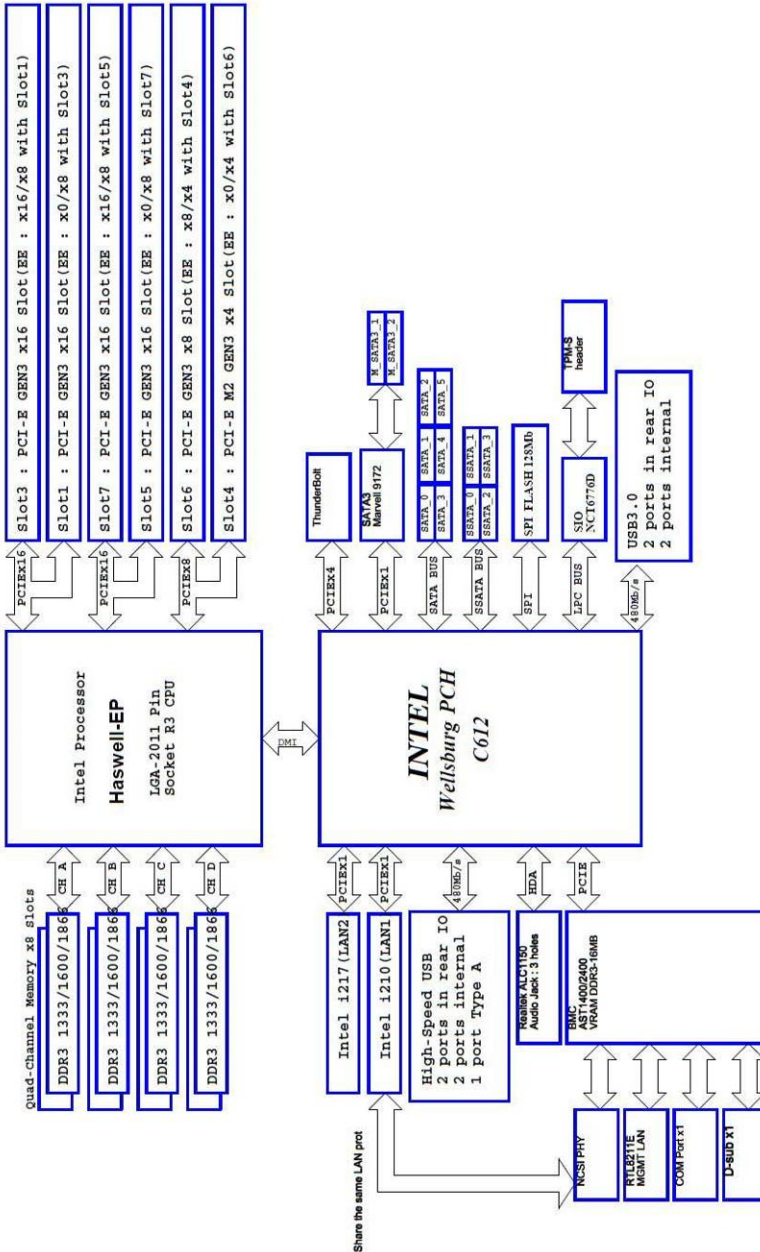

English

EPC612D8T

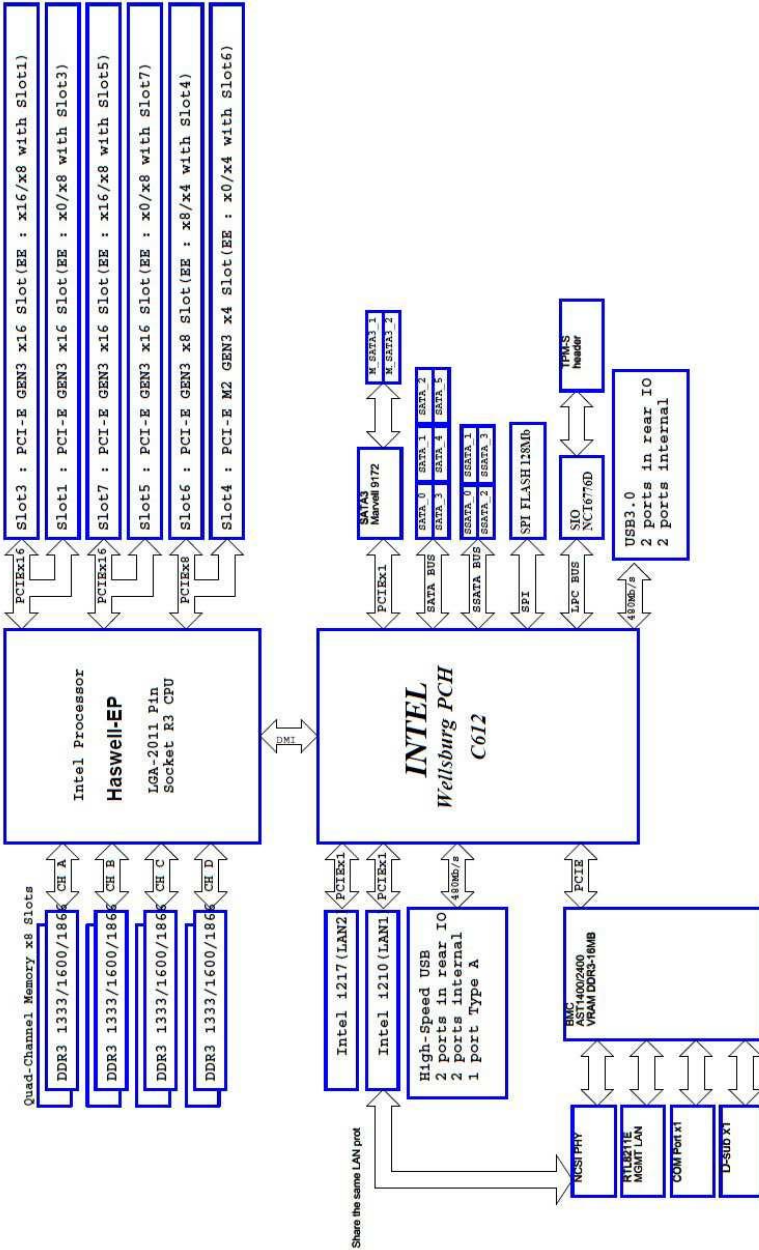

Chapter 2 Installation

This is an ATX form factor (12" x 9.6", 30.5 cm x 24.4 cm) motherboard. Before you install the motherboard, study the configuration of your chassis to ensure that the motherboard fits into it.



Make sure to unplug the power cord before installing or removing the motherboard. Failure to do so may cause physical injuries to you and damages to motherboard components.

2.1 Screw Holes

Place screws into the holes indicated by circles to secure the motherboard to the chassis.



Do not over-tighten the screws! Doing so may damage the motherboard.

2.2 Pre-installation Precautions

Take note of the following precautions before you install motherboard components or change any motherboard settings.

1. Unplug the power cord from the wall socket before touching any components.
2. To avoid damaging the motherboard's components due to static electricity, NEVER place your motherboard directly on the carpet or the like. Also remember to use a grounded wrist strap or touch a safety grounded object before you handle the components.
3. Hold components by the edges and do not touch the ICs.
4. Whenever you uninstall any component, place it on a grounded anti-static pad or in the bag that comes with the component.
5. When placing screws into the screw holes to secure the motherboard to the chassis, please do not over-tighten the screws! Doing so may damage the motherboard.



Before you install or remove any component, ensure that the power is switched off or the power cord is detached from the power supply. Failure to do so may cause severe damage to the motherboard, peripherals, and/or components.

2.3 Installing the CPU



1. Before you insert the 2011-3-Pin CPU into the socket, please check if the PnP cap is on the socket, if the CPU surface is unclean, or if there are any bent pins in the socket. Do not force to insert the CPU into the socket if above situation is found. Otherwise, the CPU will be seriously damaged.
2. Unplug all power cables before installing the CPU.

CAUTION:

Please note that C612 platform is only compatible with the LGA 2011-3 socket, which is incompatible with the LGA 2011 socket.

This motherboard only supports the DDR3 compatible CPU (E5-2669 v3, E5-2649 v3, E5-2629 v3). You cannot power on the system if you use a DDR4 compatible CPU.

Socket Type: Narrow ILM Socket

1

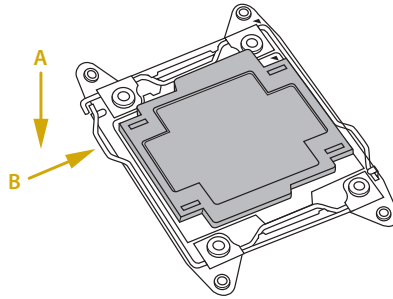

2

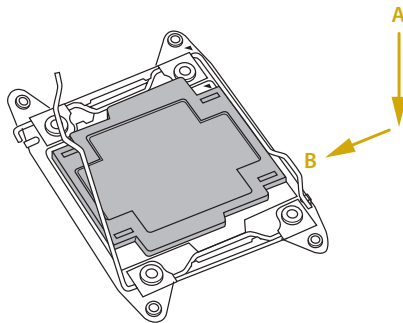

3

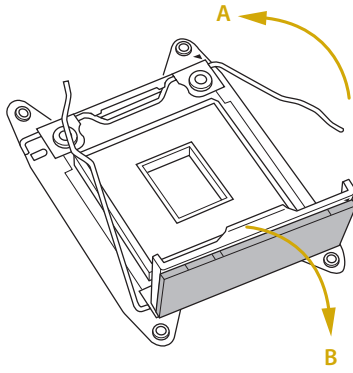

4

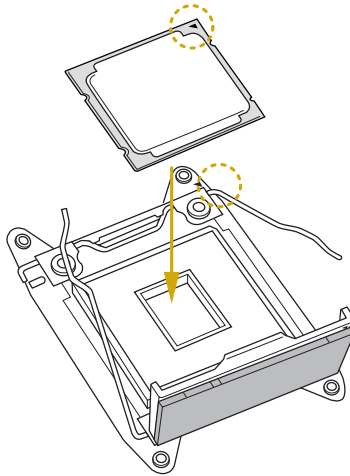

5

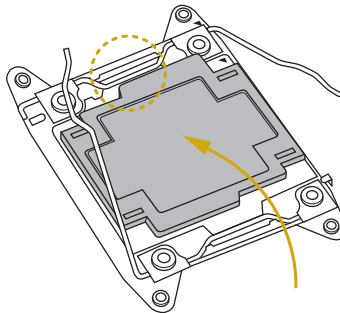

6

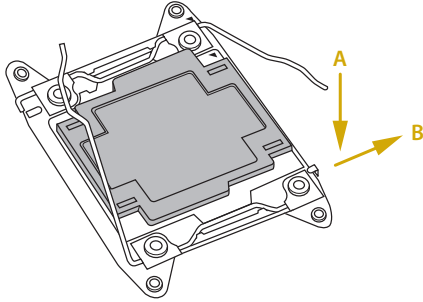

7

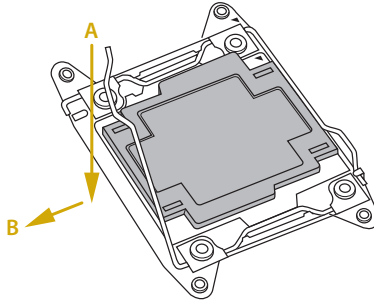

8

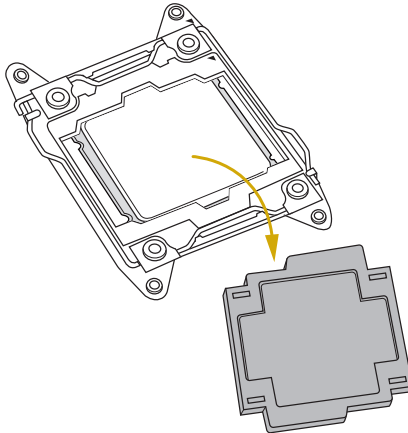

The cover must be placed if returning the motherboard for after service.

2.4 Installing the CPU Fan and Heatsink



Before you installed the heatsink, you need to spray thermal interface material between the CPU and the heatsink to improve heat dissipation.

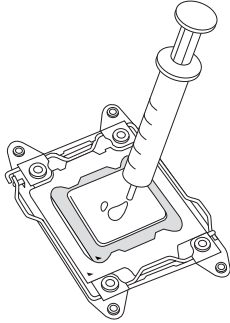

1

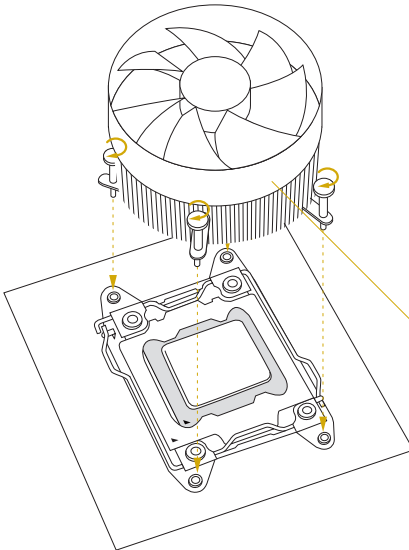

2

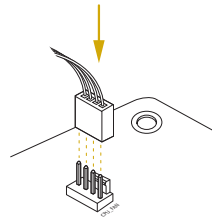

CPU fan for narrow ILM socket
*Support an active or passive heatsink

2.5 Installation of Memory Modules (DIMM)

This motherboard provides eight 240-pin DDR3 (Double Data Rate 3) DIMM slots, and supports Dual Channel Memory Technology.



1. For dual channel configuration, you always need to install identical (the same brand, speed, size and chip-type) DDR3 DIMM pairs.
2. It is unable to activate Dual Channel Memory Technology with only one or three memory module installed.
3. It is not allowed to install a DDR or DDR2 memory module into a DDR3 slot; otherwise, this motherboard and DIMM may be damaged.

Dual Channel Memory Configuration

Priority	DDR3_A1	DDR3_A2	DDR3_B1	DDR3_B2
1	Populated		Populated	
2	Populated	Populated	Populated	Populated

Priority	DDR3_C1	DDR3_C2	DDR3_D1	DDR3_D2
1	Populated		Populated	
2	Populated	Populated	Populated	Populated



The DIMM only fits in one correct orientation. It will cause permanent damage to the motherboard and the DIMM if you force the DIMM into the slot at incorrect orientation.

1

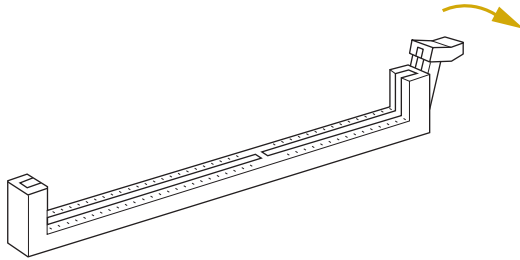

2

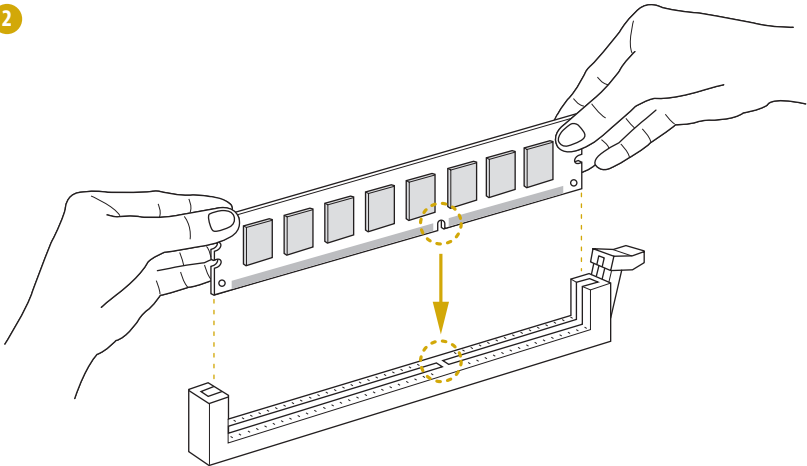

3

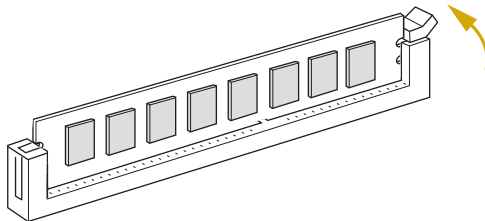

2.6 Expansion Slots (PCI and PCI Express Slots)

There are 5 PCI Express slots on this motherboard.

PCIe slot:

PCIe6 (PCIe 3.0 x8 slot, from CPU) is used for PCI Express x8 lane width graphics cards.

PCIe1 and PCIe5 (PCIe 3.0 x16 slot, from CPU) are used for PCI Express x8 lane width graphics cards.

PCIe3 and PCIe7 (PCIe 3.0 x16 slot, from CPU) are used for PCI Express x16 lane width graphics cards.

Slot	Generation	Mechanical	Electrical	Source
PCIe 7	3.0	x16	x16	CPU
PCIe 6	3.0	x8	x8	CPU
PCIe 5	3.0	x16	x8	CPU
PCIe 3	3.0	x16	x16	CPU
PCIe 1	3.0	x16	x8	CPU

PCI Express Slot Configuration

No.	PCIe 7	PCIe 3
Single Graphics Card	x16	x0
Two Graphics Cards	x8	x8

Installing an expansion card

- Step 1. Before installing an expansion card, please make sure that the power supply is switched off or the power cord is unplugged. Please read the documentation of the expansion card and make necessary hardware settings for the card before you start the installation.
- Step 2. Remove the system unit cover (if your motherboard is already installed in a chassis).
- Step 3. Remove the bracket facing the slot that you intend to use. Keep the screws for later use.
- Step 4. Align the card connector with the slot and press firmly until the card is completely seated on the slot.
- Step 5. Fasten the card to the chassis with screws.
- Step 6. Replace the system cover.

2.7 Jumper Setup

The illustration shows how jumpers are setup. When the jumper cap is placed on the pins, the jumper is “Short”. If no jumper cap is placed on the pins, the jumper is “Open”. The illustration shows a 3-pin jumper whose pin1 and pin2 are “Short” when a jumper cap is placed on these 2 pins.

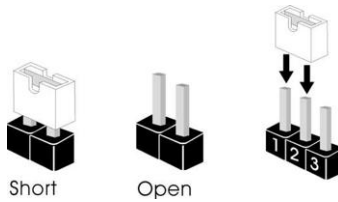

SATA DOM Power Jumper*
(3-pin SATAPWR1)
(No. 25)



SATA DOM



SATA Cable (Default)

*SATAPWR1 allows you to select the internal voltage source for the SATA DOM connected on the SATA_0 connector (No.24).

CPU PECI Mode Jumper
(3-pin PECI1)
(No. 44)



Reserved Only



CPU PECI connect to BMC
(Default)

Descriptor Security Over-ride Jumper

Chassis ID0 Jumper
(3-pin Chassis ID0)
(see p.7, No. 43)



Chassis ID1 Jumper
(3-pin Chassis ID1)
(see p.7, No. 45)



Chassis ID2 Jumper
(3-pin Chassis ID2)
(see p.7, No. 47)



Board Level SKU (Default)

Reserved for system level use

Chassis ID0 Jumper
(3-pin Chassis ID0)
(see p.7, No. 43)



Chassis ID1 Jumper
(3-pin Chassis ID1)
(see p.7, No. 45)



Chassis ID2 Jumper
(3-pin Chassis ID2)
(see p.7, No. 47)



Reserved for system level use

Reserved for system level use

Chassis ID0 Jumper
(3-pin Chassis ID0)
(see p.7, No. 43)



Chassis ID1 Jumper
(3-pin Chassis ID1)
(see p.7, No. 45)









Chassis ID2 Jumper
(3-pin Chassis ID2)
(see p.7, No. 47)



Reserved for system level use

Reserved for system level use

Chassis ID0 Jumper (3-pin Chassis ID0) (see p.7, No. 43)		
Chassis ID1 Jumper (3-pin Chassis ID1) (see p.7, No. 45)		
Chassis ID2 Jumper (3-pin Chassis ID2) (see p.7, No. 47)		
	Reserved for system level use	Reserved for system level use

2.8 Onboard Headers and Connectors



Onboard headers and connectors are NOT jumpers. Do NOT place jumper caps over these headers and connectors. Placing jumper caps over the headers and connectors will cause permanent damage to the motherboard.

System Panel Header
(9-pin PANEL1)
(No. 33)

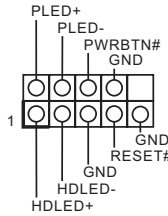

Connect the power switch, reset switch and system status indicator on the chassis to this header according to the pin assignments below. Note the positive and negative pins before connecting the cables.



PWRBTN (Power Switch):

Connect to the power switch on the chassis front panel. You may configure the way to turn off your system using the power switch.

RESET (Reset Switch):

Connect to the reset switch on the chassis front panel. Press the reset switch to restart the computer if the computer freezes and fails to perform a normal restart.

PLED (System Power LED):

Connect to the power status indicator on the chassis front panel. The LED is on when the system is operating. The LED keeps blinking when the system is in S1/S3 sleep state. The LED is off when the system is in S4 sleep state or powered off (S5).

HDLED (Hard Drive Activity LED):

Connect to the hard drive activity LED on the chassis front panel. The LED is on when the hard drive is reading or writing data.

The front panel design may differ by chassis. A front panel module mainly consists of power switch, reset switch, power LED, hard drive activity LED, speaker and etc. When connecting your chassis front panel module to this header, make sure the wire assignments and the pin assignments are matched correctly.

Auxiliary Panel Header
(18-pin AUX_PANEL_1)
(No. 35)

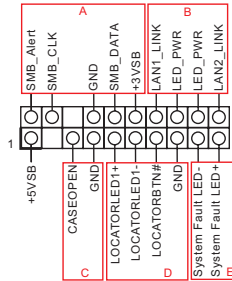

This header supports multiple functions on the front panel, including the front panel SMB, internet status indicator and chassis intrusion pin.



A. Front panel SMBus connecting pin (6-1 pin FPSMB)

This header allows you to connect SMBus (System Management Bus) equipment. It can be used for communication between peripheral equipment in the system, which has slower transmission rates, and power management equipment.

B. Internet status indicator (2-pin LAN1_LED, LAN2_LED)

These two 2-pin headers allow you to use the Gigabit internet indicator cable to connect to the LAN status indicator. When this indicator flickers, it means that the internet is properly connected.

C. Chassis intrusion pin (2-pin CHASSIS)

This header is provided for host computer chassis with chassis intrusion detection designs. In addition, it must also work with external detection equipment, such as a chassis intrusion detection sensor or a microswitch. When this function is activated, if any chassis component movement occurs, the sensor will immediately detect it and send a signal to this header, and the system will then record this chassis intrusion event. The default setting is set to the CASEOPEN and GND pin; this function is off.

D. Locator LED (4-pin LOCATOR)

This header is for the locator switch and LED on the front panel.

E. System Fault LED (2-pin LED)

This header is for the Fault LED on the system.

Serial ATA3 Connectors

(White)

(SATA_1)

(No. 18)

(SATA_2)

(No. 17)

(SATA_3)

(No. 16)

(SATA_4)

(No. 15)

(SATA_5)

(No. 27)

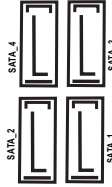

These eight SATA3 connectors support SATA data cables for internal storage devices with up to 6.0 Gb/s data transfer rate.

(SSATA_0)

(No. 20)

(SSATA_1)

(No. 19)

(SSATA_2)

(No. 28)

(SSATA_3)

(No. 29)



(M_SATA_0)

(No. 12)

(M_SATA_1)

(No. 11)



Serial ATA3 DOM

Connector

(SATA_0)

(No. 24)



The SATA3 DOM connector supports both a SATA DOM (Disk-On-Module) and a SATA data cable for internal storage device.



When connecting to a SATA DOM, no additional power cable is required. Use SATA DOM Power jumper (SATAPWR1)(No. 25) to select voltage source for SATA DOM.

USB 2.0 Header
(9-pin USB_3_4)
(No. 22)

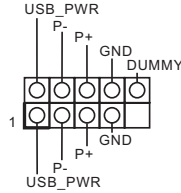

Besides two USB 2.0 ports on the I/O panel, there is one header on this motherboard. Each USB 2.0 header can support two ports.

USB 2.0 Connector
(USB_5)
(No. 31)



USB 3.0 Header
(19-pin USB3_3_4)
(No. 9)

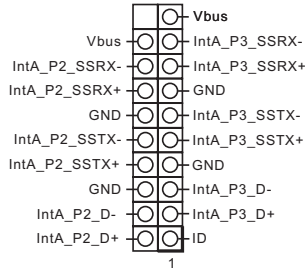

Besides two default USB 3.0 ports on the I/O panel, there is one USB 3.0 header on this motherboard. This USB 3.0 header can support two USB 3.0 ports.

Front Panel Audio Header (9-pin HD_AUDIO1) (No. 48)

**Not supported for EPC612D8T motherboard*

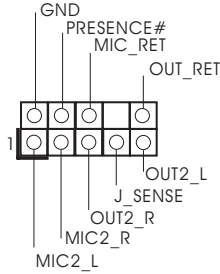

This is an interface for the front panel audio cable that allows convenient connection and control of audio devices.



1. High Definition Audio supports Jack Sensing, but the panel wire on the chassis must support HDA to function correctly. Please follow the instruction in our manual and chassis manual to install your system.

2. If you use AC'97 audio panel, please install it to the front panel audio header as below:

A. Connect Mic_IN (MIC) to MIC2_L.

B. Connect Audio_R (RIN) to OUT2_R and Audio_L (LIN) to OUT2_L.

C. Connect Ground (GND) to Ground (GND).

D. MIC_RET and OUT_RET are for HD audio panel only. You don't need to connect them for AC'97 audio panel.

Chassis Speaker Header (4-pin SPEAKER1) (No. 36)

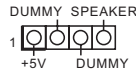

Please connect the chassis speaker to this header.

HDMI_SPDIF Header (2-pin HDMI_SPDIF1) (No. 46)

**Not supported for EPC612D8T motherboard*



HDMI_SPDIF header, providing SPDIF audio output to HDMI VGA card, allows the system to connect HDMI Digital TV/projector/LCD devices. Please connect the HDMI connector of HDMI VGA card to this header.

CPU Fan Connector (4-pin CPU_FAN1) (No. 6)

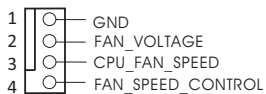

This motherboard provides a 4-Pin CPU fan (Quiet Fan) connector. If you plan to connect a 3-Pin CPU fan, please connect it to Pin 1-3.

Front and Rear Fan Connectors
 (4-pin FRONT_FAN1)
 (No. 14)
 (4-pin FRONT_FAN2)
 (No. 13)
 (4-pin FRONT_FAN3)
 (No. 32)

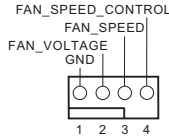

Please connect fan cables to the fan connectors and match the black wire to the ground pin. All fans support Fan Control.

(4-pin REAR_FAN1)
 (see p.8 , No. 49)
 (see p.11, No. 47)

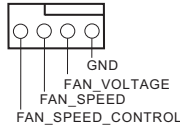

SATA Power Connectors
 (4-pin SATA_PWR1)
 (No. 30)

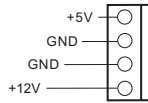

Please connect a SATA power cable.

ATX Power Connector
 (24-pin ATXPWR1)
 (No. 5)

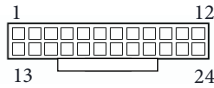

This motherboard provides a 24-pin ATX power connector. To use a 20-pin ATX power supply, please plug it along Pin 1 and Pin 13.

ATX 12V Power Connector
 (8-pin ATX12V1)
 (No. 3)

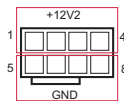

This motherboard provides a 8-pin ATX 12V power connector.

Serial Port Header
(9-pin COM2)
(No. 42)

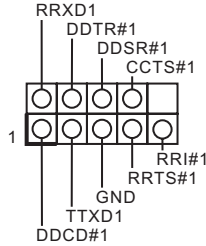

This COM2 header supports a serial port module.

TPM Header
(17-pin TPM1)
(No. 10)

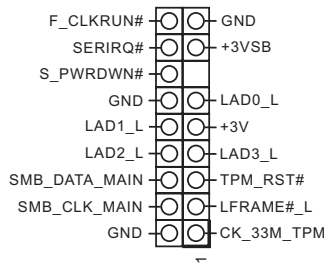

This connector supports Trusted Platform Module (TPM) system, which can securely store keys, digital certificates, passwords, and data. A TPM system also helps enhance network security, protects digital identities, and ensures platform integrity.

Serial General Purpose
Input/Output Headers
(7-pin SATA_SGPIO1)
(No. 21)
(7-pin SATA_SGPIO2)
(No. 26)
(7-pin SATA_SGPIO3)
(No. 23)

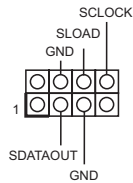

These headers support Serial Link interface for onboard SATA connections.

PSU SMBus
(PSU_SMB1)
(No. 4)

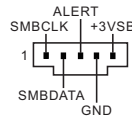

PSU SMBus monitors the status of the power supply, fan and system temperature.

Non Maskable Interrupt
Button Header
(NMI_BTN1)
(No. 41)

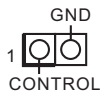

Please connect a NMI device to this header.

Intelligent Platform
Management Bus header
(4-pin IPMB_1)
(No. 37)

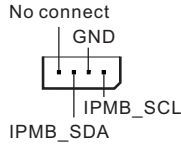

This 4-pin connector is used to provide a cabled base-board or front panel connection for value added features and 3rd-party add-in cards, such as Emergency Management cards, that provide management features using the IPMB.

Thermal Sensor Header
(3-pin TR1)
(No. 34)

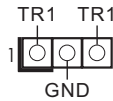

Please connect the thermal sensor cable to either pin 1-2 or pin 2-3 and the other end to the device which you wish to monitor its temperature.

Baseboard Management
Controller SMBus Headers
(5-pin BMC_SMB_1)
(No. 40)
(5-pin BMC_SMB_2)
(No. 39)
(5-pin BMC_SMB_3)
(No. 38)

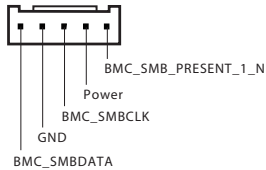

These headers are used for the SM BUS devices.

2.9 Dr. Debug

Dr. Debug is used to provide code information, which makes troubleshooting even easier. Please see the diagrams below for reading the Dr. Debug codes.

Code	Description
00	Please check if the CPU is installed correctly and then clear CMOS.
0d	Problem related to memory, VGA card or other devices. Please clear CMOS, re-install the memory and VGA card, and remove other USB, PCI devices.
01 - 54 (except 0d), 5A- 60	Problem related to memory. Please re-install the CPU and memory then clear CMOS. If the problem still exists, please install only one memory module or try using other memory modules.
55	The Memory could not be detected. Please re-install the memory and CPU. If the problem still exists, please install only one memory module or try using other memory modules.
61 - 91	Chipset initialization error. Please press reset or clear CMOS.
92 - 99	Problem related to PCI-E devices. Please re-install PCI-E devices or try installing them in other slots. If the problem still exists, please remove all PCI-E devices or try using another VGA card.
A0 - A7	Problem related to IDE or SATA devices. Please re-install IDE and SATA devices. If the problem still exists, please clear CMOS and try removing all SATA devices.
b0	Problem related to memory. Please re-install the CPU and memory. If the problem still exists, please install only one memory module or try using other memory modules.
b4	Problem related to USB devices. Please try removing all USB devices.
b7	Problem related to memory. Please re-install the CPU and memory then clear CMOS. If the problem still exists, please install only one memory module or try using other memory modules.
d6	The VGA could not be recognized. Please clear CMOS and try re-installing the VGA card. If the problem still exists, please try installing the VGA card in other slots or use other VGA cards.
d7	The Keyboard and mouse could not be recognized. Please try re-installing the keyboard and mouse.
d8	Invalid Password.
FF	Please check if the CPU is installed correctly and then clear CMOS.

2.10 Driver Installation Guide

To install the drivers to your system, please insert the support CD to your optical drive first. Then, the drivers compatible to your system can be auto-detected and listed on the support CD driver page. Please follow the order from top to bottom to install those required drivers. Therefore, the drivers you install can work properly.

2.12 DisplayPort Input

The DisplayPort Input on the motherboard allows you to utilize the power of discrete graphics with a Thunderbolt™ display connected.

Connection Diagram (Using Graphics card with DisplayPort)

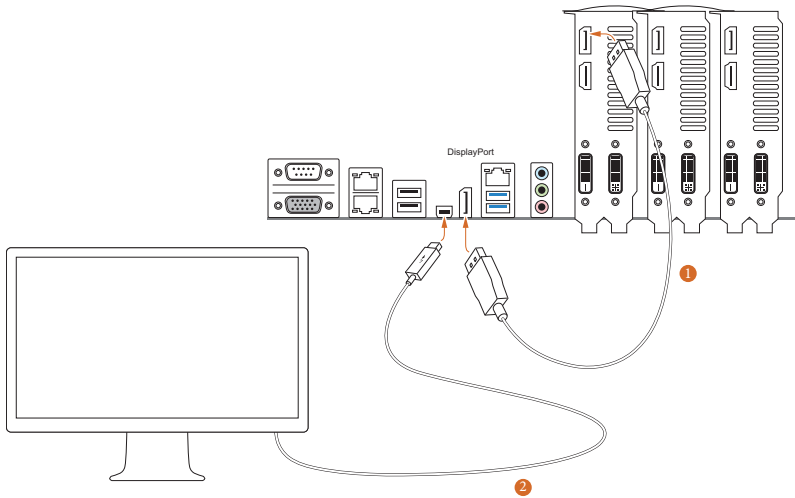

1. Connect one end of the DisplayPort Cable to the **DisplayPort** of the graphics card. Then connect the other end of the cable to the **DisplayPort Input** on the rear I/O panel.

DisplayPort Cable

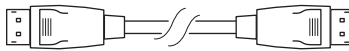

2. Connect your Thunderbolt™ 2 display to the **Thunderbolt™ 2 Port (TBT1)** on the rear I/O panel using a Thunderbolt™ cable.

Thunderbolt™ cable



2.11 Dual LAN and Teaming Operation Guide

Dual LAN with Teaming enabled on this motherboard allows two single connections to act as one single connection for twice the transmission bandwidth, making data transmission more effective and improving the quality of transmission of distant images. Fault tolerance on the dual LAN network prevents network downtime by transferring the workload from a failed port to a working port.



The speed of transmission is subject to the actual network environment or status even with Teaming enabled.

Before setting up Teaming, please make sure whether your Switch (or Router) supports Teaming (IEEE 802.3ad Link Aggregation). You can specify a preferred adapter in Intel® PROSet. Under normal conditions, the Primary adapter handles all non-TCP/IP traffic. The Secondary adapter will receive fallback traffic if the primary fails. If the Preferred Primary adapter fails, but is later restored to an active status, control is automatically switched back to the Preferred Primary adapter.

Step 1

From **Device Manager**, open the properties of a team.

Step 2

Click the **Settings** tab.

Step 3

Click the **Modify Team** button.

Step 4

Select the adapter you want to be the primary adapter and click the **Set Primary** button.

If you do not specify a preferred primary adapter, the software will choose an adapter of the highest capability (model and speed) to act as the default primary. If a failover occurs, another adapter becomes the primary. The adapter will, however, rejoin the team as a non-primary.

2.12 M.2_SSD (NGFF) Module Installation Guide

The M.2, also known as the Next Generation Form Factor (NGFF), is a small size and versatile card edge connector that aims to replace mPCIe and mSATA. The M.2_SSD (NGFF) Socket 3 can accommodate either a M.2 SATA3 6.0 Gb/s module or a M.2 PCI Express module up to Gen 2 x2 (10 Gb/s). Please be noted that the M.2_SSD (NGFF) Socket 3 is shared with the SATA Express connector; you can only choose either the M.2_SSD (NGFF) Socket 3 or the SATA Express connector to use.

*The M.2_SSD (NGFF) Socket 3 supports SSD drives. Please note that the WiFi or other non-SSD M.2 modules are not supported.

Installing the M.2_SSD (NGFF) Module

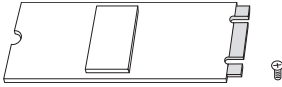

Step 1

Prepare a M.2_SSD (NGFF) module and the screw.

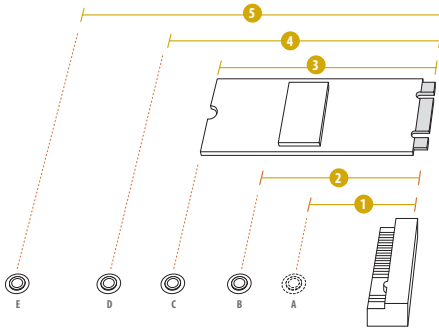

Step 2

Depending on the PCB type and length of your M.2_SSD (NGFF) module, find the corresponding nut location to be used.

No.	1	2	3	4	5
Nut Location	A	B	C	D	E
PCB Length	3cm	4.2cm	6cm	8cm	11cm
Module Type	Type2230	Type 2242	Type2260	Type 2280	Type 22110

Step 3



Move the standoff based on the module type and length. The standoff is placed at the nut location D by default. Skip Step 3 and 4 and go straight to Step 5 if you are going to use the default nut. Otherwise, release the standoff by hand.

Step 4



Peel off the yellow protective film on the nut to be used. Hand tighten the standoff into the desired nut location on the motherboard.

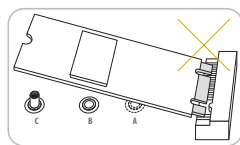

Step 5

Align and gently insert the M.2 (NGFF) SSD module into the M.2 slot. Please be aware that the M.2 (NGFF) SSD module only fits in one orientation.

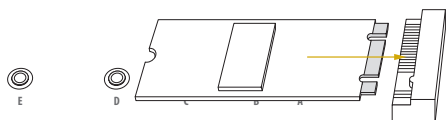

Step 6

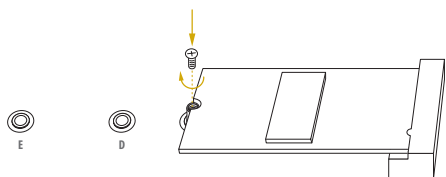

Tighten the screw with a screwdriver to secure the module into place. Please do not overtighten the screw as this might damage the module.

M.2_SSD (NGFF) Module Support List

PCIe Interface	SATA Interface
Plextor PX-AG256M6e	ADATA AXNS381E-128GM-B
Plextor PX-AG512M6e	ADATA AXNS381E-256GM-B
SanDisk SD6PP4M-128G	Crucial CT120M500SSD4/120G
SanDisk SD6PP4M-256G	Crucial CT240M500SSD4/240G
Samsung XP941-512G (MZHPU512HCGL)	Intel SSDSCKGW080A401/80G
	Kingston RBU-SNS8400S3/180GD

For the latest updates of M.2_SSD (NFGG) module support list, please visit our website for details: <http://www.asrockrack.com>

Chapter 3 UEFI Setup Utility

3.1 Introduction

This section explains how to use the UEFI SETUP UTILITY to configure your system. The UEFI chip on the motherboard stores the UEFI SETUP UTILITY. You may run the UEFI SETUP UTILITY when you start up the computer. Please press <F2> or during the Power-On-Self-Test (POST) to enter the UEFI SETUP UTILITY; otherwise, POST will continue with its test routines.

If you wish to enter the UEFI SETUP UTILITY after POST, restart the system by pressing <Ctrl> + <Alt> + <Delete>, or by pressing the reset button on the system chassis. You may also restart by turning the system off and then back on.



Because the UEFI software is constantly being updated, the following UEFI setup screens and descriptions are for reference purpose only, and they may not exactly match what you see on your screen.

3.1.1 UEFI Menu Bar

The top of the screen has a menu bar with the following selections:

Item	Description
Main	To set up the system time/date information
Advanced	To set up the advanced UEFI features
Server Mgmt	To manage the server
Security	To set up the security features
Boot	To set up the default system device to locate and load the Operating System
Event Logs	For event log configuration
Exit	To exit the current screen or the UEFI SETUP UTILITY

Use <←> key or <→> key to choose among the selections on the menu bar, and then press <Enter> to get into the sub screen. You can also use the mouse to click your required item.

3.1.2 Navigation Keys

Please check the following table for the function description of each navigation key.

Navigation Key(s)	Function Description
← / →	Moves cursor left or right to select Screens
↑ / ↓	Moves cursor up or down to select items
+ / -	To change option for the selected items
<Tab>	Switch to next function
<Enter>	To bring up the selected screen
<PGUP>	Go to the previous page
<PGDN>	Go to the next page
<HOME>	Go to the top of the screen
<END>	Go to the bottom of the screen
<F1>	To display the General Help Screen
<F7>	Discard changes and exit the UEFI SETUP UTILITY
<F9>	Load optimal default values for all the settings
<F10>	Save changes and exit the UEFI SETUP UTILITY
<F12>	Print screen
<ESC>	Jump to the Exit Screen or exit the current screen

3.2 Main Screen

Once you enter the UEFI SETUP UTILITY, the Main screen will appear and display the system overview. The Main screen provides system overview information and allows you to set the system time and date.

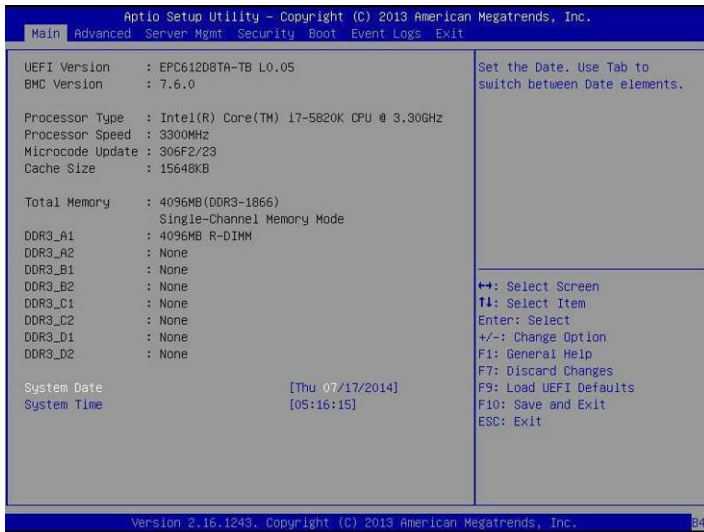

3.3 Advanced Screen

In this section, you may set the configurations for the following items: CPU Configuration, DRAM Configuration, ACPI Configuration, Configure Super IO Settings, Serial Port Console Redirection, USB Configuration, Chipset Configuration, Storage Configuration, H/W Monitor, Intel ME Configuration, Easy RAID Installer and Instant Flash.

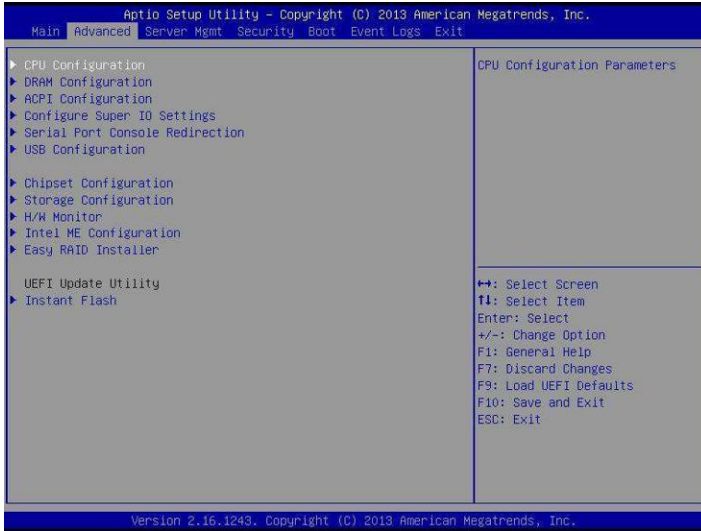

Setting wrong values in this section may cause the system to malfunction.

3.3.1 CPU Configuration



Intel Hyper Threading Technology

Intel Hyper Threading Technology allows multiple threads to run on each core, so that the overall performance on threaded software is improved.

Active Processor Cores

Use this item to select the number of cores to enable in each processor package.

No-Execute Memory Protection

Processors with No-Execution Memory Protection Technology may prevent certain classes of malicious buffer overflow attacks.

Enable Intel TXT Support

Enable Intel Trusted Execution Technology configuration. Please disable “EX DFX 60 English Features” when TXT is enabled.

Intel Virtualization Technology

Intel Virtualization Technology allows a platform to run multiple operating systems and applications in independent partitions, so that one computer system can function as multiple virtual system.

Hardware Prefetcher

Use this item to automatically prefetch data and code for the processor. Enable for better performance.

Adjacent Cache Line Prefetch

Automatically prefetch the subsequent cache line while retrieving the currently requested cache line. Enable for better performance.

CPU Thermal Throttling

Enable CPU internal thermal control mechanisms to keep the CPU from overheating.

CPU C States Support

Enable CPU C States Support for power saving. It is recommended to keep C3 and C6 enabled for better power saving.

Package C State Support

Enable CPU, PCIe, Memory, Graphics C State Support for power saving.

CPU C3 State Support

Enable C3 sleep state for lower power consumption.

CPU C6 State Support

Enable C6 deep sleep state for lower power consumption.

Enhanced Halt State(C1E)

Enable Enhanced Halt State (C1E) for lower power consumption.

3.3.2 DRAM Configuration

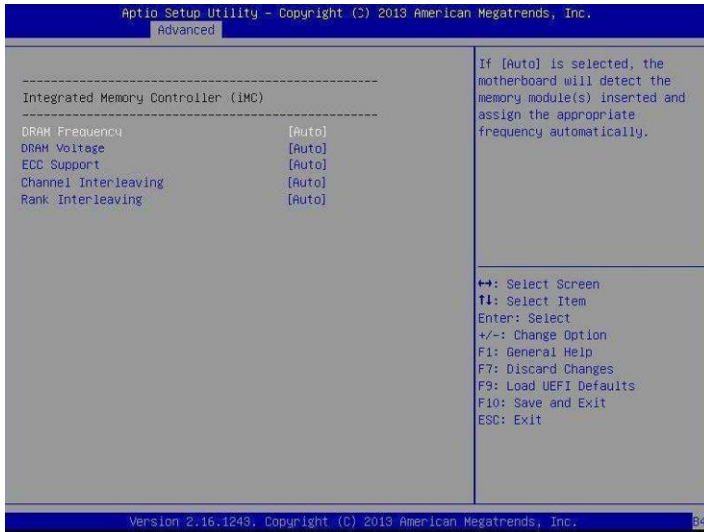

DRAM Frequency

If [Auto] is selected, the motherboard will detect the memory module(s) inserted and assign the appropriate frequency automatically.

DRAM Voltage

Use this item to configure DRAM Voltage Configuration.

ECC Support

This allows you to enable or disable the DDR ECC support feature.

Channel Interleaving

Use this item to select Channel Interleaving setting.

Rank Interleaving

Use this item to select Rank Interleaving setting.

3.3.3 ACPI Configuration

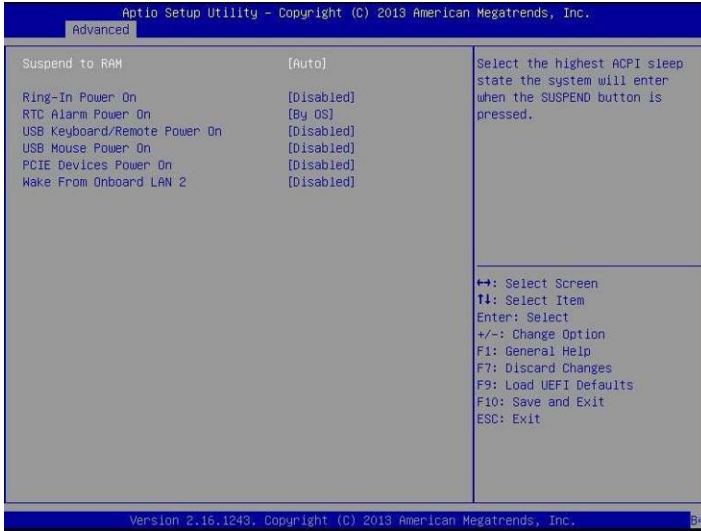

Suspend to RAM

Use this item to select whether to auto-detect or disable the Suspend-to-RAM feature. Selecting [Auto] will enable this feature if the OS supports it.

Ring-In Power On

Use this item to enable or disable Ring-In signals to turn on the system from the power-soft-off mode.

RTC Alarm Power On

Use this item to enable or disable RTC (Real Time Clock) to power on the system.

USB Keyboard/Remote Power On

Use this item to enable or disable USB Keyboard/Remote to turn on the system from the power-soft-off mode.

USB Mouse Power On

Use this item to enable or disable USB Mouse to turn on the system from the power-soft-off mode.

PCIE Devices Power On

Use this item to enable or disable PCIE devices to turn on the system from the power-soft-off mode.

Wake From Onboard LAN 2

It allows the system to be waked up by the Onboard Intel LAN.

3.3.4 Configure Super IO Settings



Serial Port 1 Configuration

Use this item to configure the onboard serial port 1.

Select and enter the "Serial Port 1 Configuration" and you will see the followings:

Serial Port

Use this item to enable or disable the onboard serial port.

Change Settings

Use this item to select an optimal setting for Super IO device.

Serial Port 2 Configuration

Use this item to configure the onboard serial port 2.

Select and enter the "Serial Port 2 Configuration" and you will see the followings:

Serial Port

Use this item to enable or disable the onboard serial port.

Change Settings

Use this item to select an optimal setting for Super IO device.

Serial Port Mode

Use this item to select Serial Over LAN or COM mode.

3.3.5 Serial Port Console Redirection

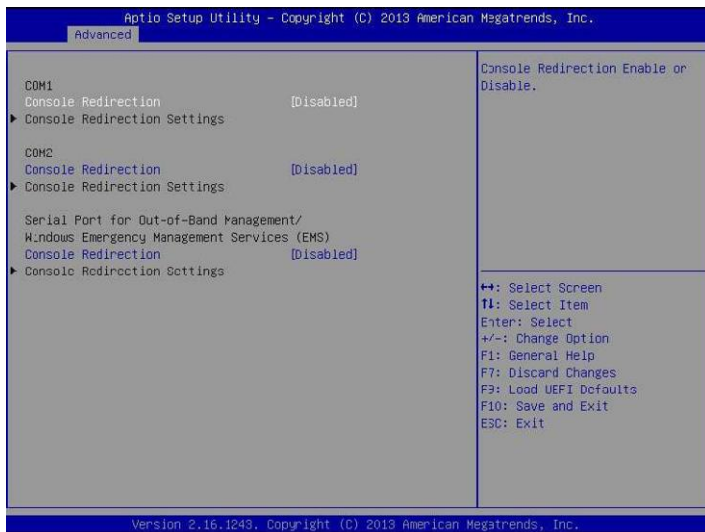

Console Redirection

Use this option to enable or disable Console Redirection. If this item is set to Enabled, you can select a COM Port to be used for Console Redirection.

Console Redirection Settings

Use this option to configure Console Redirection Settings, and specify how your computer and the host computer to which you are connected exchange information.

Terminal Type

Use this item to select the preferred terminal emulation type for out-of-band management. It is recommended to select [VT-UTF8].

Option	Description
VT100	ASCII character set
VT100+	Extended VT100 that supports color and function keys
VT-UTF8	UTF8 encoding is used to map Unicode chars onto 1 or more bytes
ANSI	Extended ASCII character set

Bits Per Second

Use this item to select the serial port transmission speed. The speed used in the host computer and the client computer must be the same. Long or noisy lines may require lower transmission speed. The options include [9600], [19200], [57600] and [115200].

Data Bits

Use this item to set the data transmission size. The options include [7] and [8] (Bits).

Parity

Use this item to select the parity bit. The options include [None], [Even], [Odd], [Mark] and [Space].

Stop Bits

The item indicates the end of a serial data packet. The standard setting is [1] Stop Bit. Select [2] Stop Bits for slower devices.

Flow Control

Use this item to set the flow control to prevent data loss from buffer overflow. When sending data, if the receiving buffers are full, a "stop" signal can be sent to stop the data flow. Once the buffers are empty, a "start" signal can be sent to restart the flow. Hardware flow uses two wires to send start/stop signals. The options include [None], [Hardware RTS/CTS], and [Software Xon/Xoff].

VT-UTF8 Combo Key Support

Use this item to enable or disable the VT-UTF8 Combo Key Support for ANSI/VT100 terminals.

Recorder Mode

Use this item to enable or disable Recorder Mode to capture terminal data and send it as text messages.

Resolution 100x31

Use this item to enable or disable extended terminal resolution support.

Legacy OS Redirection Resolution

Use this item to select the number of rows and columns used in legacy OS redirection.

Putty Keypad

Use this item to select Function Key and Keypad on Putty.

Redirection After BIOS POST

If the [LoadBooster] is selected, legacy console redirection is disabled before booting to legacy OS. If [Always Enabled] is selected, legacy console redirection is enabled for legacy OS. The default value is [Always Enabled].

3.3.6 USB Configuration

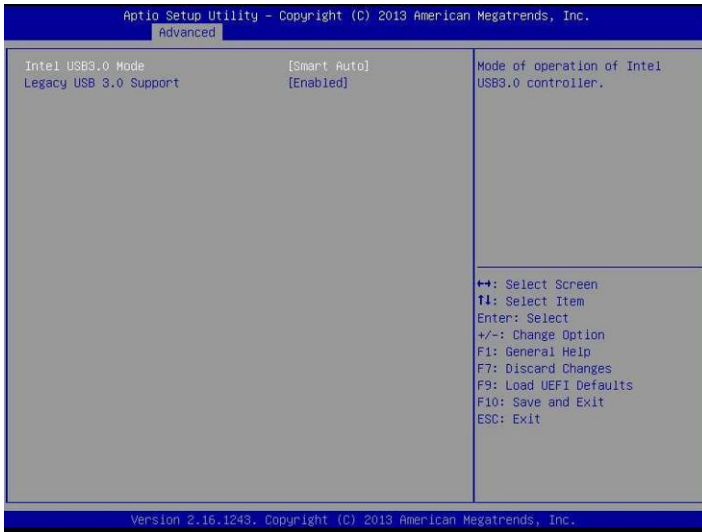

Intel USB3.0 Mode

Use this item to select the mode of operation of Intel USB3.0 controller.

Legacy USB 3.0 Support

Use this item to enable or disable Legacy OS Support for USB 3.0 devices.

3.3.7 Chipset Configuration

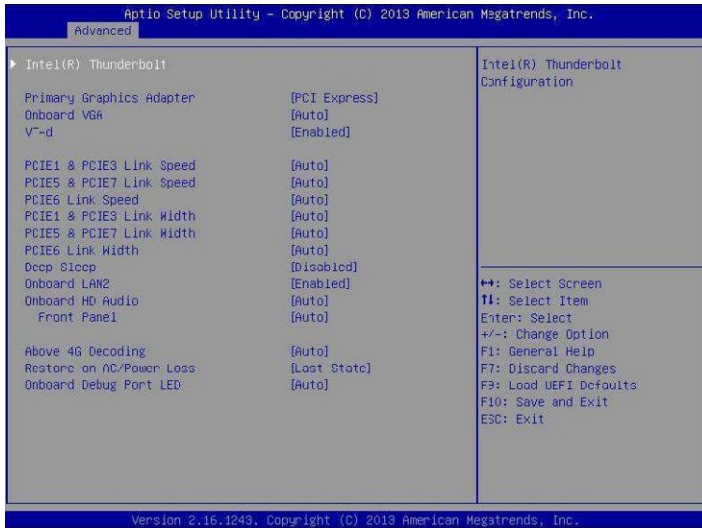

Intel(R) Thunderbolt *(Only for EPC612D8TA-TB motherboard)*

Intel Thunderbolt™ Technology

Enable or disable the Intel® Thunderbolt™ function.

Security Level

Select Legacy to skip the Windows certification checking process for Thunderbolt™ devices. Select Unique ID for checking the Windows certification, and show warning messages if the devices aren't certified. Or select DP++ to support DP 1.2.

TBT Device IO resource Support

Enable IO Resource Support if your older Thunderbolt devices have trouble working properly.

Thunderbolt™ PCIe Cache-line Size

Configure the cache-line size of the Thunderbolt PCIe subtree.

Primary Graphics Adapter

If PCI Express graphics card is installed on the motherboard, you may use this option to select PCI Express or Onboard as the primary graphics adapter.

Onboard VGA

Use this to enable or disable the Onboard VGA function. The default value is [Auto].

**This item is not available when the Primary Graphic Adapter is set to [Onboard].*

VT-d

Intel Virtualization Technology for Directed I/O helps your virtual machine monitor better utilize hardware by improving application compatibility and reliability, and providing additional levels of manageability, security, isolation, and I/O performance.

PCIE 1 & PCIE 3 Link Speed

This allows you to select PCIE 1 & PCIE 3 Link Speed. The default value is [Auto].

PCIE 5 & PCIE 7 Link Speed

This allows you to select PCIE 5 & PCIE 7 Link Speed. The default value is [Auto].

PCIE 6 Link Speed

This allows you to select PCIE 6 Link Speed. The default value is [Auto].

PCIE 1 & PCIE 3 Link Width

This allows you to select PCIE 1 & PCIE 3 Link Width. The default value is [Auto].

PCIE 5 & PCIE 7 Link Width

This allows you to select PCIE 3 & PCIE 4 Link Width. The default value is [Auto].

PCIE 6 Link Width

This allows you to select PCIE 6 Link Width. The default value is [Auto].

PCIE ASPM Support

This option enables or disables the ASPM support for all CPU downstream devices.

PCH PCIE ASPM Support

This option enables or disables the ASPM support for all PCH downstream devices.

Deep Sleep

Configure deep sleep mode for power saving when the computer is shut down. We recommend disabling Deep Sleep for better system compatibility and stability.

Onboard LAN2

This allows you to enable or disable the Onboard LAN 2 feature.

Onboard HD Audio *(Only for EPC612D8TA-TB / EPC612D8TA motherboard)*

Use this item to automatically enable or disable onboard HD audio. Set to Auto to enable onboard HD audio and automatically disable it when a sound card is installed.

Front Panel *(Only for EPC612D8TA-TB / EPC612D8TA motherboard)*

Use this item to set front panel HD audio to Auto or Disabled.

Above 4G Decoding

Enable or disable 64bit capable Devices to be decoded in Above 4G Address Space (only if the system supports 64 bit PCI decoding).

Restore on AC/Power Loss

This allows you to set the power state after an unexpected AC/power loss. If [Power Off] is selected, the AC/power remains off when the power recovers. If [Power On] is selected, the AC/power resumes and the system starts to boot up when the power recovers. If [Last State] is selected, it will recover to the state before AC/power loss.

Onboard Debug Port LED

Use this item to turn on or off Onboard Debug Port LED.

3.3.8 Storage Configuration

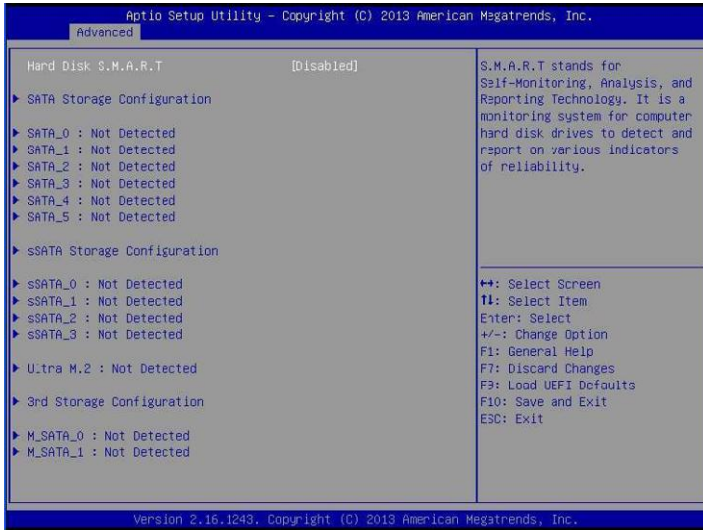

Hard Disk S.M.A.R.T.

Use this item to enable or disable the S.M.A.R.T. (Self-Monitoring, Analysis, and Reporting Technology) feature. Configuration options: [Disabled] and [Enabled].

SATA Storage Configuration

SATA Controller

Use this item to enable or disable SATA Controller.

SATA Mode Selection

Use this to select SATA mode. Configuration options: [Disabled], [IDE Mode], [AHCI Mode] and [RAID Mode]. The default value is [AHCI Mode].



AHCI (Advanced Host Controller Interface) supports NCQ and other new features that will improve SATA disk performance but IDE mode does not have these advantages.

SATA Aggressive Link Power Mgmt

Use this item to configure SATA Aggressive Link Power Management.

SATA Port 0 / 1 / 2 / 3 / 4 / 5

Depending on how many SATA ports you have, you will see SATA_x (x means number) listed on the screen, with its status indicated as SATA device [(Model Name)] or [Not Detected].

External SATA

Use this item to enable SATA safe removal notifications. Please note that the SATA device will be downgraded to SATA2.

Hot Plug

Designates this port as Hot Pluggable.

Spin Up Device

If enabled for any of ports, Staggered Spin Up will be performed and only the drives which have this option enabled will spin up at boot. Otherwise all drives spin up at boot.

SATA Rx Setting

Adjust SATA DTLE DATA Values (0-15).

SATA Device Type

Identify the SATA port connected to Solid State Drive or Hard Disk Drive.

sSATA Storage Configuration

sSATA Controller

Use this item to enable or disable sSATA Controller.

sSATA Mode Selection

Use this to select sSATA mode. Configuration options: [Disabled], [IDE Mode], [AHCI Mode] and [RAID Mode]. The default value is [AHCI Mode].



AHCI (Advanced Host Controller Interface) supports NCQ and other new features that will improve SATA disk performance but IDE mode does not have these advantages.

sSATA Aggressive Link Power Management

Use this item to configure sSATA Aggressive Link Power Management.

sSATA Port 0 / 1 / 2 / 3

Depending on how many sSATA ports you have, you will see sSATA_x (x means number) listed on the screen, with its status indicated as SATA device [(Model Name)] or [Not

Detected].

External sSATA

Use this item to enable SATA safe removal notifications. Please note that the SATA device will be downgraded to SATA2.

Hot Plug

Designates this port as Hot Pluggable.

Spin Up Device

If enabled for any of ports, Staggered Spin Up will be performed and only the drives which have this option enabled will spin up at boot. Otherwise all drives spin up at boot.

SATA Rx Setting

Adjust SATA DTLE DATA Values (0-15).

SATA Device Type

Identify the SATA port connected to Solid State Drive or Hard Disk Drive.

Ultra M.2

3rd Storage Configuration

Marvell 9172 Controller

Enable or disable Marvell 9172 Controller.

Marvell 9172 Operation Mode

This item is for M_SATA ports. Use this to select Marvell SATA operation mode. Configuration options: [IDE Mode], [AHCI Mode] and [RAID Mode]. The default value is [AHCI Mode]. Press <Ctrl-M> to enter RAID ROM during UEFI POST process.

Bootable Marvell 9172 SATA3

We recommend to use Intel SATA ports (Port 0~5) for your bootable devices. This will minimize your boot time and get the best performance. If you still want to boot from Marvell SATA3 controller, please set this item to [Yes].

M_SATA_0 / M_SATA_1

Depending on how many M_SATA ports you have, you will see M_SATA_x (x means number) listed on the screen, with its status indicated as SATA device [(Model Name)] or [Not Detected].

3.3.9 H/W Monitor Screen

In this section, it allows you to monitor the status of the hardware on your system, including the parameters of the CPU temperature, motherboard temperature, CPU fan speed, chassis fan speed, and the critical voltage.

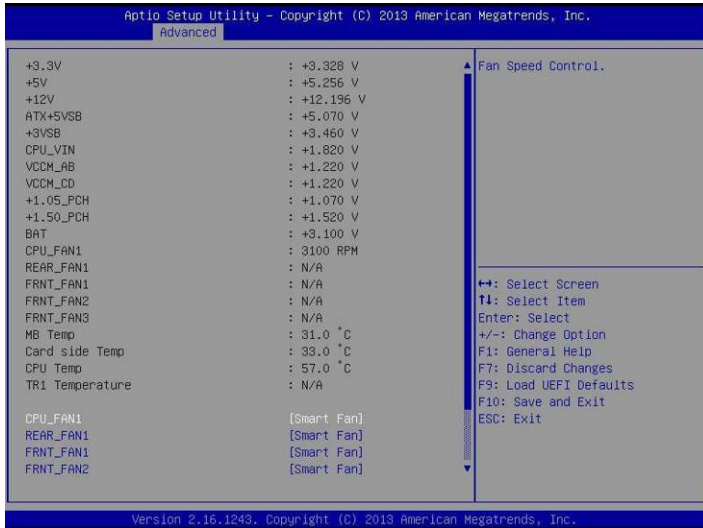

CPU_FAN 1

This allows you to set the CPU fan 1's speed. The default value is [Smart Fan].

REAR_FAN 1

This allows you to set the rear fan 1's speed. The default value is [Smart Fan].

FRNT_FAN 1

This allows you to set the front fan 1's speed. The default value is [Smart Fan].

FRNT_FAN 2

This allows you to set the front fan 2's speed. The default value is [Smart Fan].

FRNT_FAN 3

This allows you to set the front fan 3's speed. The default value is [Smart Fan].

Smart Fan Control

This allows you to set the Smart fan's level speed.

Smart Fan Duty Control

Smart Fan Duty x (x means 1 to 11 stage)

This allows you to set duty cycle for each stage.

Smart Fan Temp Control

Smart Fan Temp x (x means 1 to 11 stage)

This allows you to set temperature for each stage.

Watch Dog Timer

This allows you to enable or disable the Watch Dog Timer. The default value is [Disabled].

3.3.10 Intel ME Configuration

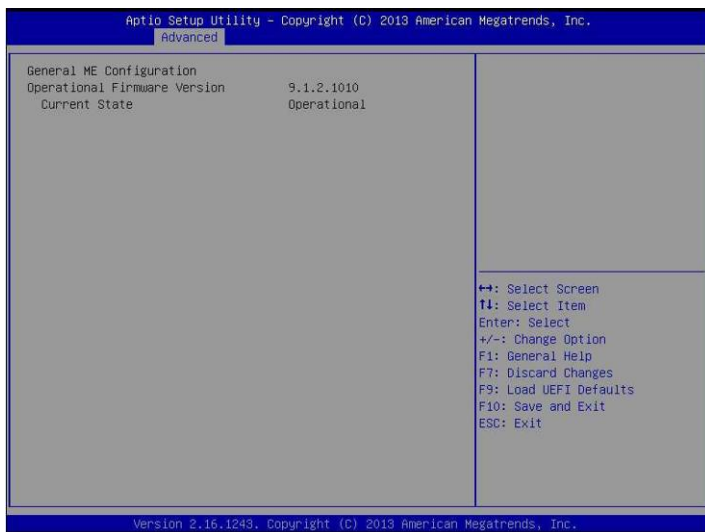

ME Subsystem screen displays the Intel ME Subsystem Configuration information, such as Operational Firmware Version, ME Firmware, ME Firmware Type, ME Firmware SKU and ME File System Integrity Value.

3.3.11 Easy RAID Installer

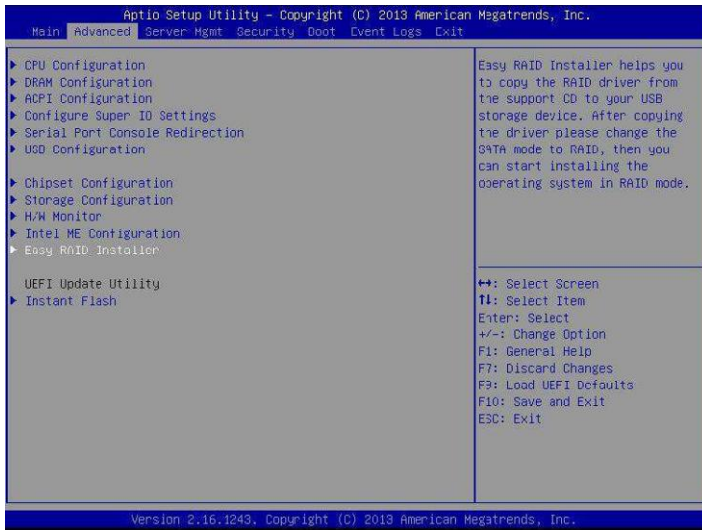

Easy RAID Installer can help you to copy the RAID driver from a support CD to your USB storage device. After copying the RAID driver to your USB storage device, please change “SATA Mode” to “RAID”, then you can start installing the OS in RAID mode.

3.3.12 Instant Flash

Instant Flash is a UEFI flash utility embedded in Flash ROM. This convenient UEFI update tool allows you to update system UEFI without entering operating systems first like MS-DOS or Windows. Just save the new UEFI file to your USB flash drive, floppy disk or hard drive and launch this tool, then you can update your UEFI only in a few clicks without preparing an additional floppy diskette or other complicated flash utility. Please be noted that the USB flash drive or hard drive must use FAT32/16/12 file system. If you execute Instant Flash utility, the utility will show the UEFI files and their respective information. Select the proper UEFI file to update your UEFI, and reboot your system after the UEFI update process is completed.

3.4 Server Mgmt (Server Management)



Wait For BMC

Wait For BMC response for specified time out. In PILOTII, BMC starts at the same time when BIOS starts during AC power ON. It takes around 30 seconds to initialize Host to BMC interfaces.

System Event Log

Press <Enter> to change the SEL event log configuration.

SEL Components

Change this to enable or disable all features of System Event Logging during boot.

Erase SEL

Use this to choose options for erasing SEL.

When SEL is Full

Use this to choose options for reactions to a full SEL.

Log EFI Status Codes

Use this item to disable the logging of EFI Status Codes or log only error code or only progress or both.

BMC Network Configuration

Enter to configure BMC Network parameters.

Configuration Address Source

Select to configure BMC network parameters statically or dynamically (by BIOS or BMC).
Configuration options: [Unspecified], [Static], and [Dynamic].

Unspecified: BMC network parameters are configured by BMC itself.

Static: Manually enter the IP Address, Subnet Mask and Gateway Address in the BIOS for BMC LAN channel configuration.

Dynamic: IP address, Subnet Mask and Gateway Address are automatically assigned by the network's DHCP server.

To configure BMC network parameters using the BIOS setup, select either [Static] or [Dynamic] option.

To configure BMC network parameters using the BMC web interface, select [Unspecified] option.



When [Dynamic] or [Static] is selected, do NOT modify the BMC network settings on the IPMI web page.

BMC Mac Backup Tool

Use this to restore BMC Mac from the backup.

3.5 Security Screen

In this section, you may set or change the supervisor/user password for the system. For the user password, you may also clear it.

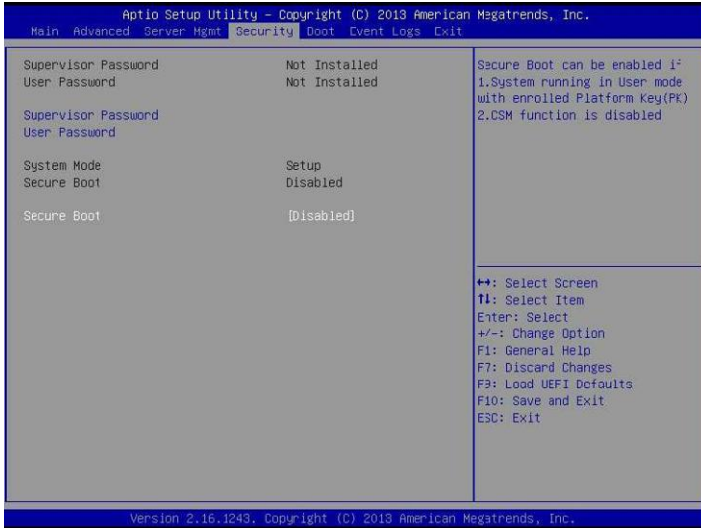

Supervisor Password

Set or change the password for the administrator account. Only the administrator has authority to change the settings in the UEFI Setup Utility. Leave it blank and press enter to remove the password.

User Password

Set or change the password for the user account. Users are unable to change the settings in the UEFI Setup Utility. Leave it blank and press enter to remove the password.

Secure Boot

Secure Boot can be enabled if 1. System running in User mode with enrolled Platform Key(PK) 2. CSM function is disabled.

3.6 Boot Screen

In this section, it will display the available devices on your system for you to configure the boot settings and the boot priority.



Boot Option #1

Use this item to set the system boot order.

Boot From Onboard LAN

Use this item to enable or disable the Boot From Onboard LAN feature.

Setup Prompt Timeout

This shows the number of seconds to wait for setup activation key.

Bootup Num-Lock

If this item is set to [On], it will automatically activate the Numeric Lock function after boot-up.

Boot Beep

Select whether the Boot Beep should be turned on or off when the system boots up. Please note that a buzzer is needed.

Full Screen Logo

Use this item to enable or disable OEM Logo. The default value is [Enabled].

AddOn ROM Display

Use this option to adjust AddOn ROM Display. If you enable the option “Full Screen Logo” but you want to see the AddOn ROM information when the system boots, please select [Enabled]. Configuration options: [Enabled] and [Disabled]. The default value is [Enabled].

Boot Failure Guard

If the computer fails to boot for a number of times the system automatically restores the default settings.

Boot Failure Guard Count

Configure the number of attempts to boot until the system automatically restores the default settings.

CSM Parameters

Use this option to configure the parameters of OpROM execution, boot options filter, etc.

CSM

Enable to launch the Compatibility Support Module. If you are using Windows 8 64-bit UEFI and all of your devices support UEFI, you may also disable CSM for faster boot speed.

Boot Option Filter

Use this option to control what devices system can boot to. Configuration options: [UEFI and Legacy], [Legacy only] and [UEFI only].

Launch Storage OpROM Policy

Select UEFI only to run those that support UEFI option ROM only. Select [Legacy only] to run those that support legacy option ROM only. Select [Do not launch] to not to execute both legacy and UEFI option ROM.

Launch Video OpROM Policy

Select UEFI only to run those that support UEFI option ROM only. Select [Legacy only] to run those that support legacy option ROM only.

3.7 Event Logs

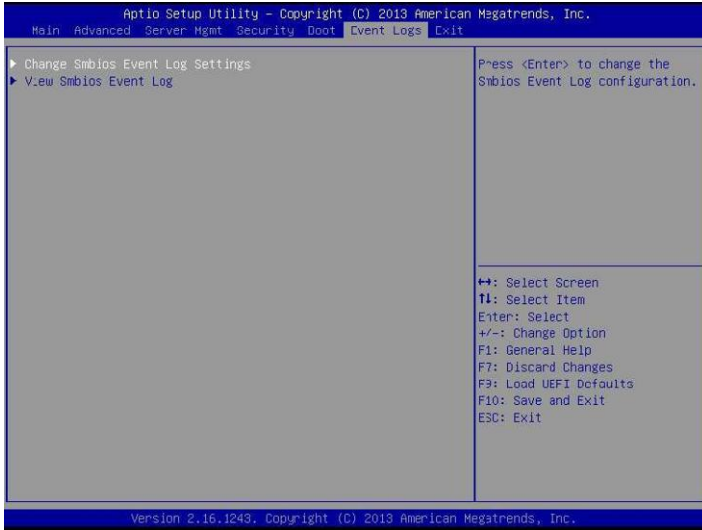

Change Smbios Event Log Settings

This allows you to configure the Smbios Event Log Settings.

When entering the item, you will see the followings:

Smbios Event Log

Use this item to enable or disable all features of the SMBIOS Event Logging during system boot.

Erase Event Log

The options include [No], [Yes, Next reset] and [Yes, Every reset]. If Yes is selected, all logged events will be erased.

When Log is Full

Use this item to choose options for reactions to a full Smbios Event Log. The options include [Do Nothing] and [Erase Immediately].

MECI (Multiple Event Count Increment)

Use this item to enter the increment value for the multiple event counter. The valid range is from 1 to 255.

METW (Multiple Event Time Window)

Use this item to specify the number of minutes which must pass between duplicate log entries which utilize a multiple-event counter. The value ranges from 0 to 99 minutes.

View Smbios Event Log

This allows you to view the Smbios Event Log records.



All values changed here do not take effect until computer is restarted.

3.8 Exit Screen



Save Changes and Exit

When you select this option, the following message “Save configuration changes and exit setup?” will pop-out. Select [Yes] to save the changes and exit the UEFI SETUP UTILITY.

Discard Changes and Exit

When you select this option, the following message “Discard changes and exit setup?” will pop-out. Select [Yes] to exit the UEFI SETUP UTILITY without saving any changes.

Discard Changes

When you select this option, the following message “Discard changes?” will pop-out. Select [Yes] to discard all changes.

Load UEFI Defaults

Load UEFI default values for all the setup questions. F9 key can be used for this operation.

Chapter 4 Software Support

4.1 Install Operating System

This motherboard supports various Microsoft® Windows® 7 / 8/ 8.1 / Server 2008 R2 SP1 / 2012 / 2012 R2 / Linux compliant. Because motherboard settings and hardware options vary, use the setup procedures in this chapter for general reference only. Refer to your OS documentation for more information.

4.2 Support CD Information

The Support CD that came with the motherboard contains necessary drivers and useful utilities that enhance the motherboard's features.

4.2.1 Running The Support CD

To begin using the support CD, insert the CD into your CD-ROM drive. The CD automatically displays the Main Menu if "AUTORUN" is enabled in your computer. If the Main Menu does not appear automatically, locate and double click on the file "ASRSetup.exe" from the root folder in the Support CD to display the menu.

4.2.2 Drivers Menu

The Drivers Menu shows the available device's drivers if the system detects installed devices. Please install the necessary drivers to activate the devices.

4.2.3 Utilities Menu

The Utilities Menu shows the application softwares that the motherboard supports. Click on a specific item then follow the installation wizard to install it.

4.2.4 Contact Information

If you need to contact ASRock Rack or want to know more about ASRock Rack, welcome to visit ASRock Rack's website at <http://www.ASRockRack.com>; or you may contact your dealer for further information.

Chapter 5 Troubleshooting

5.1 Troubleshooting Procedures

Follow the procedures below to troubleshoot your system.



Always unplug the power cord before adding, removing or changing any hardware components. Failure to do so may cause physical injuries to you and damages to motherboard components.

1. Disconnect the power cable and check whether the PWR LED is off.
2. Unplug all cables, connectors and remove all add-on cards from the motherboard. Make sure that the jumpers are set to default settings.
3. Confirm that there are no short circuits between the motherboard and the chassis.
4. Install a CPU and fan on the motherboard, then connect the chassis speaker and power LED.

If there is no power...

1. Confirm that there are no short circuits between the motherboard and the chassis.
2. Make sure that the jumpers are set to default settings.
3. Check the settings of the 115V/230V switch on the power supply.
4. Verify if the battery on the motherboard provides ~3VDC. Install a new battery if it does not.

If there is no video...

1. Try replugging the monitor cables and power cord.
2. Check for memory errors.

If there are memory errors...

1. Verify that the DIMM modules are properly seated in the slots.
2. Use recommended DDR3 1600/1333/1066 non ECC, unbuffered DIMMs.
3. If you have installed more than one DIMM modules, they should be identical with the same brand, speed, size and chip-type.
4. Try inserting different DIMM modules into different slots to identify faulty ones.
5. Check the settings of the 115V/230V switch on the power supply.

Unable to save system setup configurations...

1. Verify if the battery on the motherboard provides ~3VDC. Install a new battery if it does not.
2. Confirm whether your power supply provides adequate and stable power.

Other problems...

1. Try searching keywords related to your problem on ASRock Rack's FAQ page:
<http://www.asrockrack.com/support>

5.2 Technical Support Procedures

If you have tried the troubleshooting procedures mentioned above and the problems are still unsolved, please contact ASRock Rack's technical support with the following information:

1. Your contact information
2. Model name, BIOS version and problem type.
3. System configuration.
4. Problem description.

You may contact ASRock Rack's technical support at:

<http://www.asrockrack.com/support/tsd.asp>

5.3 Returning Merchandise for Service

For warranty service, the receipt or a copy of your invoice marked with the date of purchase is required. By calling your vendor or going to our RMA website (<http://event.asrockrack.com/tsd.asp>) you may obtain a Returned Merchandise Authorization (RMA) number.

The RMA number should be displayed on the outside of the shipping carton which is mailed prepaid or hand-carried when you return the motherboard to the manufacturer. Shipping and handling charges will be applied for all orders that must be mailed when service is complete.

This warranty does not cover damages incurred in shipping or from failure due to alteration, misuse, abuse or improper maintenance of products.

Contact your distributor first for any product related problems during the warranty period.

Chapter 6: Net Framework Installation Guide

To let Intel® RSTe works properly, it is required to install Net Framework. Please follow the steps below to enable “.Net Framework” feature on Microsoft® Windows® Server 2008 R2.

6.1 Installing .Net Framework 3.5.1 (For Server 2008 R2)

1. Double-click the Server Manager icon in the Windows system tray.

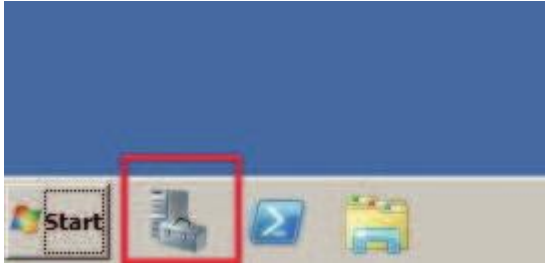

2. Click Add Features in the right hand pane.

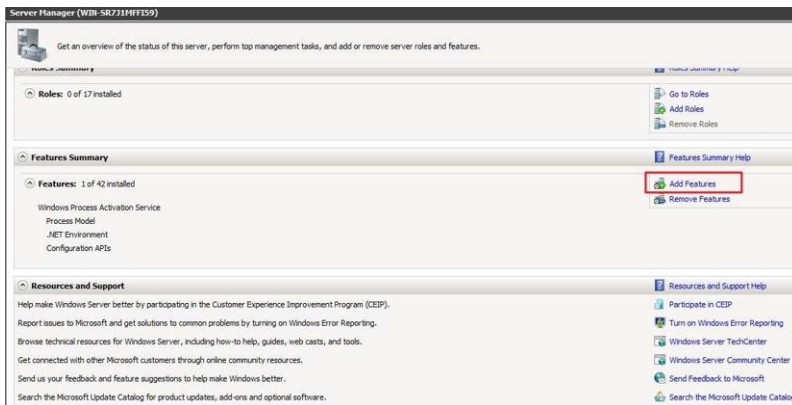

3. Check the box next to .Net Framework 3.5.1 and then click **Next**.

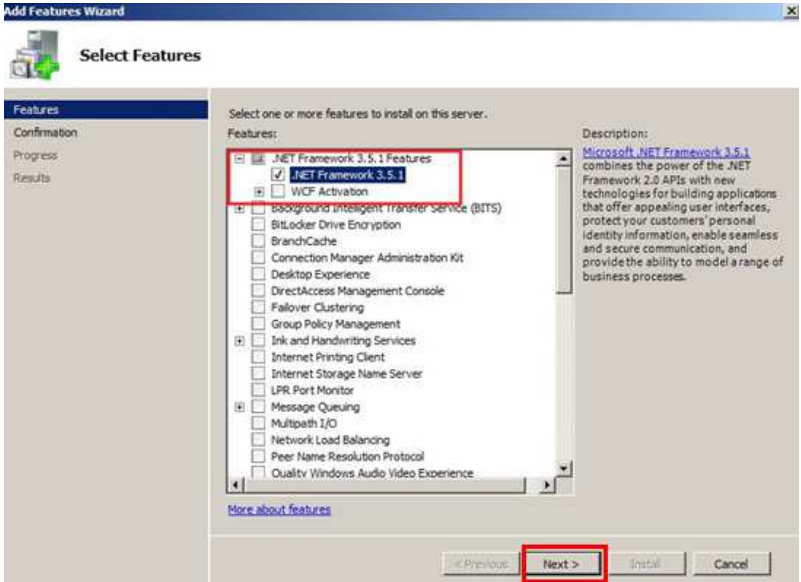

4. Click **Next** to continue.

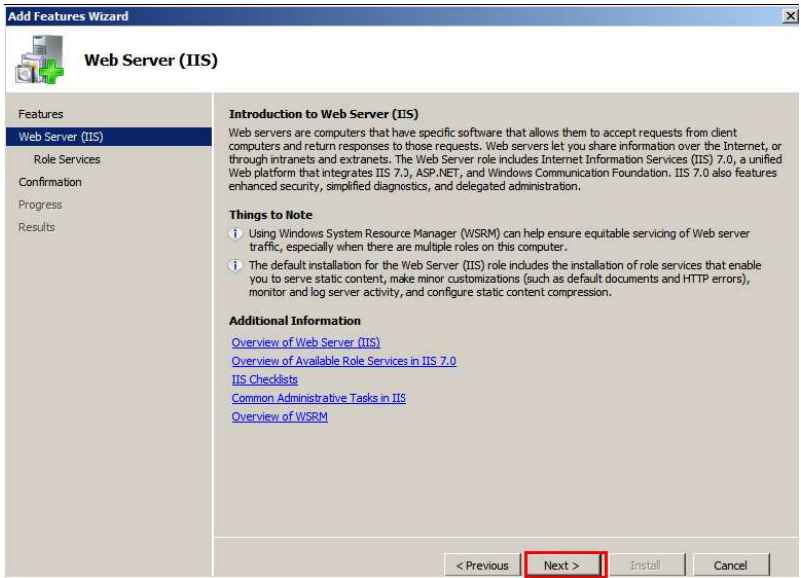

5. Click **Install** to start installing .Net Framework 3.5.1.

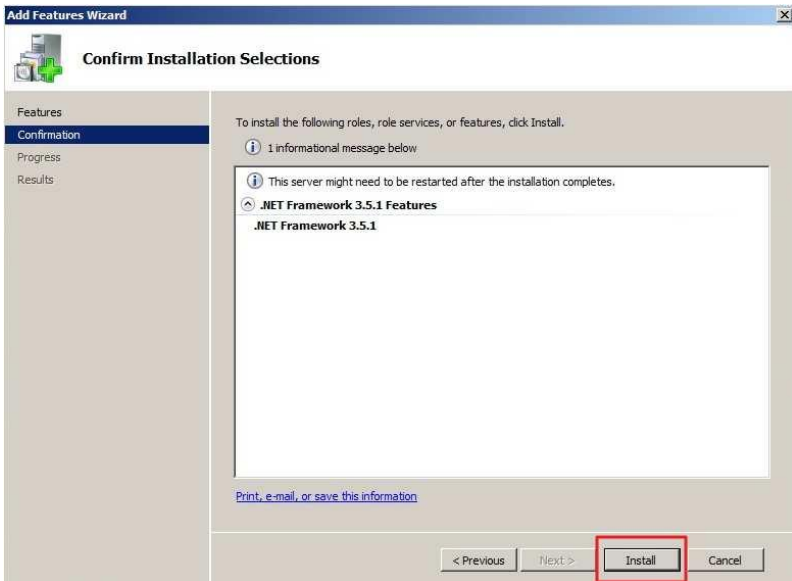

6. After the installation completes, click **Close**.

