

**ASRock**



# ***B550M-P***

User Manual

## Contact Information

If you need to contact ASRock or want to know more about ASRock, you're welcome to visit ASRock's website at <http://www.asrock.com>; or you may contact your dealer for further information. For technical questions, please submit a support request form at <https://event.asrock.com/tsd.asp>

### **ASRock Incorporation**

e-mail: [info@asrock.com.tw](mailto:info@asrock.com.tw)

### **ASRock EUROPE B.V.**

e-mail: [sales@asrock.nl](mailto:sales@asrock.nl)

### **ASRock America, Inc.**

e-mail: [sales@asrockamerica.com](mailto:sales@asrockamerica.com)



Scan the QR code to view more manuals and documents.

# Contents

<b>Chapter 1 Introduction</b>	<b>1</b>
1.1 Package Contents	1
1.2 Specifications	2
1.3 Motherboard Layout	6
1.4 I/O Panel	8
1.5 Block Diagram	10
<b>Chapter 2 Installation</b>	<b>11</b>
2.1 Installing the CPU	12
2.2 Installing the CPU Fan and Heatsink	14
2.3 Installing Memory Modules (DIMM)	22
2.4 Connecting the Front Panel Header	25
2.5 Installing the I/O Panel Shield	26
2.6 Installing the Motherboard	27
2.7 Installing SATA Drives	28
2.8 Installing a Graphics Card	30
2.9 Connecting Peripheral Devices	32
2.10 Connecting the Power Connectors	33
2.11 Power On	34
2.12 Jumpers Setup	35
2.13 Onboard Headers and Connectors	36
2.14 M.2 WiFi/BT Module Installation Guide	49
2.15 M.2 SSD Installation Guide (M2_1)	51

# Chapter 1 Introduction

Thank you for purchasing ASRock B550M-Pmotherboard, a reliable motherboard produced under ASRock's consistently stringent quality control. It delivers excellent performance with robust design conforming to ASRock's commitment to quality and endurance.



*Because the motherboard specifications and the BIOS software might be updated, the content of this documentation will be subject to change without notice. In case any modifications of this documentation occur, the updated version will be available on ASRock's website without further notice. If you require technical support related to this motherboard, please visit our website for specific information about the model you are using. You may find the latest VGA cards and CPU support list on ASRock's website as well. ASRock website <http://www.asrock.com>.*

## 1.1 Package Contents

- ASRock B550M-P Motherboard (Micro ATX Form Factor)
- 1 x I/O Panel Shield
- 2 x Serial ATA (SATA) Data Cables (Optional)
- 1 x Screw for M.2 Socket (Optional)

## 1.2 Specifications

**Platform** • Micro ATX Form Factor

**CPU** • Supports AMD AM4 Socket Ryzen™ 3000, 3000 G-Series, 4000 G-Series, 5000 and 5000 G-Series Desktop Processors\*  
\* Please refer to CPU support list for details.

**Chipset** • AMD B550

**Memory**

- Dual Channel DDR4 Memory Technology
- 4 x DDR4 DIMM Slots
- AMD Ryzen series CPUs (Vermeer) support DDR4 4600+(OC)/4533(OC)/4466(OC)/4400(OC)/4333(OC)/4266(OC)/4200(OC)/4133(OC)/4000(OC)/3866(OC)/3800(OC)/3733(OC)/3600(OC)/3466(OC)/3200/2933/2667/2400/2133 ECC & non-ECC, un-buffered memory\*
- AMD Ryzen series CPUs (Matisse) support DDR4 4600+(OC)/4533(OC)/4466(OC)/4400(OC)/4333(OC)/4333(OC)/4266(OC)/4200(OC)/4133(OC)/4000(OC)/3866(OC)/3800(OC)/3733(OC)/3600(OC)/3466(OC)/3200/2933/2667/2400/2133 ECC & non-ECC, un-buffered memory\*
- AMD Ryzen series APUs (Cezanne) support DDR4 4733+(OC)/4666(OC)/4600(OC)/4533(OC)/4466(OC)/4400(OC)/4333(OC)/4266(OC)/4200(OC)/4133(OC)/4000(OC)/3866(OC)/3800(OC)/3733(OC)/3600(OC)/3466(OC)/3200/2933/2667/2400/2133 ECC & non-ECC, un-buffered memory\*
- AMD Ryzen series APUs (Renoir) support DDR4 4733+(OC)/4666(OC)/4600(OC)/4533(OC)/4466(OC)/4400(OC)/4333(OC)/4266(OC)/4200(OC)/4133(OC)/4000(OC)/3866(OC)/3800(OC)/3733(OC)/3600(OC)/3466(OC)/3200/2933/2667/2400/2133 ECC & non-ECC, un-buffered memory\*
- AMD Ryzen series APUs (Picasso) support DDR4 3333+(OC)/3200(OC)/2933/2667/2400/2133 non-ECC, un-buffered memory\*

\* For Ryzen Series APUs (Picasso, Cezanne and Renoir), ECC is only supported with PRO CPUs.

\* Please refer to Memory Support List on ASRock's website for more information. (<http://www.asrock.com/>)

- Max. capacity of system memory: 64GB
- Supports Extreme Memory Profile (XMP) memory modules
- 15 $\mu$  Gold Contact in DIMM Slots

### Expansion Slot

CPU:

- 1 x PCIe 4.0 x16 Slot (PCIe2), supports x16 mode\*

\* Supports NVMe SSD as boot disks

Chipset:

- 1 x PCIe 3.0 x1 Slot (PCIe1)
  
- 1 x M.2 Socket (Key E), supports type 2230 WiFi/BT PCIe WiFi module

### Graphics

- Integrated AMD Radeon™ Vega Series Graphics in Ryzen Series APU (Actual support may vary by CPU)
- Supports HDMI 2.1 with max. resolution up to 4K x 2K (4096x2160) @ 60Hz
- Supports DisplayPort 1.4 with max. resolution up to 5K (5120x2880)@120Hz

### Audio

- 7.1 CH HD Audio (Realtek ALC897 Audio Codec)

### LAN

- 2.5 Gigabit LAN 10/100/1000/2500 Mb/s
- Dragon RTL8125BG
- Supports Dragon 2.5G LAN Software
  - Smart Auto Adjust Bandwidth Control
  - Visual User Friendly UI
  - Visual Network Usage Statistics
  - Optimized Default Setting for Game, Browser, and Streaming Modes
  - User Customized Priority Control

## USB

### CPU:

- 1 x USB 3.2 Gen1 Type-C (Rear)
- 3 x USB 3.2 Gen1 Type-A (3 Rear (USB32\_1 and USB32\_23))

### Chipset:

- 1 x USB 3.2 Gen1 Type-C (Front)
- 3 x USB 3.2 Gen1 Type-A (1 Rear (USB32\_4), 2 Front)
- 4 x USB 2.0 (1 Rear, 3 Front)

\* All USB ports support ESD Protection

## Rear Panel I/O

- 1 x HDMI Port
- 1 x DisplayPort 1.4
- 1 x USB 3.2 Gen1 Type-C Port
- 4 x USB 3.2 Gen1 Type-A Ports
- 1 x USB 2.0 Port
- 1 x RJ-45 LAN Port
- HD Audio Jacks: Line in / Front Speaker / Microphone

## Storage

### CPU:

- 1 x Hyper M.2 Socket (M2\_1, Key M), supports type 2260/2280 SATA3 6.0 Gb/s & PCIe Gen4x4 (64 Gb/s) modes\*

### Chipset:

- 4 x SATA3 6.0 Gb/s Connectors

\* Supports NVMe SSD as boot disks

\* NVMe SSD is not supported with AMD Athlon™ 3000G Processors

## RAID

- Supports RAID 0, RAID 1 and RAID 10 for SATA storage devices

**Connector**

- 1 x SPI TPM Header
- 1 x COM Port Header
- 1 x Chassis Intrusion and Speaker Header
- 1 x RGB LED Header\*
- 3 x Addressable LED Headers\*\*
- 1 x CPU Fan Connector (4-pin) (Smart Fan Speed Control)\*\*\*
- 2 x Chassis Fan Connectors (4-pin) (Smart Fan Speed Control)\*\*\*\*
- 1 x 24 pin ATX Power Connector
- 1 x 4 pin 12V Power Connector
- 1 x Front Panel Audio Connector
- 2 x USB 2.0 Headers (Support 3 USB 2.0 ports)
- 1 x USB 3.2 Gen1 Header (Supports 2 USB 3.2 Gen1 ports)
- 1 x Front Panel Type C USB 3.2 Gen1 Header

\* Supports in total up to 12V/3A, 36W LED Strip

\*\* Support in total up to 5V/3A, 15W LED Strip

\*\*\* CPU\_FAN1, CHA\_FAN1 supports the fan power up to 1A (12W).

\*\*\*\* CHA\_FAN2 support the fan power up to 2A (24W).

\*\*\*\* CHA\_FAN2 can auto detect if 3-pin or 4-pin fan is in use

**BIOS  
Feature**

- AMI UEFI Legal BIOS with GUI support

**OS**

- Microsoft® Windows® 10 64-bit / 11 64-bit

**Certifica-  
tions**

- FCC, CE
- ErP/EuP ready (ErP/EuP ready power supply is required)

\* For detailed product information, please visit our website: <http://www.asrock.com>



Please realize that there is a certain risk involved with overclocking, including adjusting the setting in the BIOS, applying Untied Overclocking Technology, or using third-party overclocking tools. Overclocking may affect your system's stability, or even cause damage to the components and devices of your system. It should be done at your own risk and expense. We are not responsible for possible damage caused by overclocking.

# 1.3 Motherboard Layout

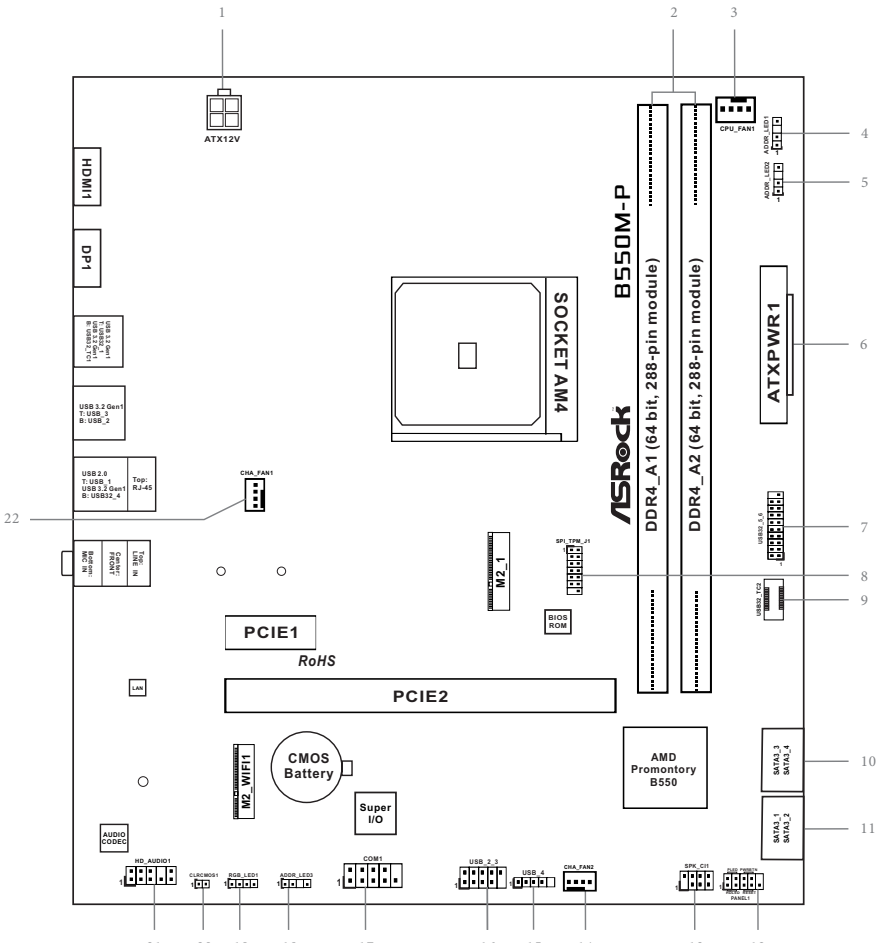

No.	Description
1	8 pin 12V Power Connector (ATX12V1)
2	2 x 288-pin DDR4 DIMM Slots (DDR4_A1, DDR4_B1)
3	CPU Fan Connector (CPU_FAN1)
4	Addressable LED Header (ADDR_LED1)
5	Addressable LED Header (ADDR_LED2)
6	ATX Power Connector (ATXPWR1)
7	USB 3.2 Gen1 Header (USB32_5_6)
8	SPI TPM Header (SPI_TPM_J1)
9	Front Panel Type C USB 3.2 Gen1 Header (USB32_TC2)
10	SATA3 Connector (SATA3_3) (Upper), SATA3 Connector (SATA3_4) (Lower)
11	SATA3 Connector (SATA3_1) (Upper), SATA3 Connector (SATA3_2) (Lower)
12	System Panel Header (PANEL1)
13	Chassis Intrusion and Speaker Header (SPK_CI1)
14	Chassis Fan Connector (CHA_FAN2)
15	USB 2.0 Header (USB_4)
16	USB 2.0 Header (USB_2_3)
17	COM Port Header (COM1)
18	Addressable LED Header (ADDR_LED3)
19	RGB LED Header (RGB_LED1)
20	Clear CMOS Jumper (CLRCMOS1)
21	Front Panel Audio Header (HD_AUDIO1)
22	Chassis Fan Connector (CHA_FAN1)

## 1.4 I/O Panel



No.	Description	No.	Description
1	2.5G LAN RJ-45 Port*	7	USB 3.2 Gen1 Type-A Ports (USB32_23)
2	Line In (Light Blue)**	8	USB 3.2 Gen1 Type-A Port (USB32_1)
3	Front Speaker (Lime)**	9	USB 3.2 Gen1 Type-C Port (USB32_TC1)
4	Microphone (Pink)**	10	DisplayPort 1.4
5	USB 2.0 Port (USB_1)	11	HDMI Port
6	USB 3.2 Gen1 Type-A Port (USB32_4)		

\*There are two LEDs on each LAN port. Please refer to the table below for the LAN port LED indications.

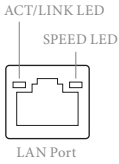

Activity / Link LED		Speed LED	
Status	Description	Status	Description
Off	No Link	Off	10Mbps connection
Blinking	Data Activity	Orange	100Mbps/1Gbps connection
On	Link	Green	2.5Gbps connection

\*\* Function of the Audio Ports in 7.1-channel Configuration:

Port	Function
Light Blue (Rear panel)	Rear Speaker Out
Lime (Rear panel)	Front Speaker Out
Pink (Rear panel)	Central /Subwoofer Speaker Out
Lime (Front panel)	Side Speaker Out

# 1.5 Block Diagram

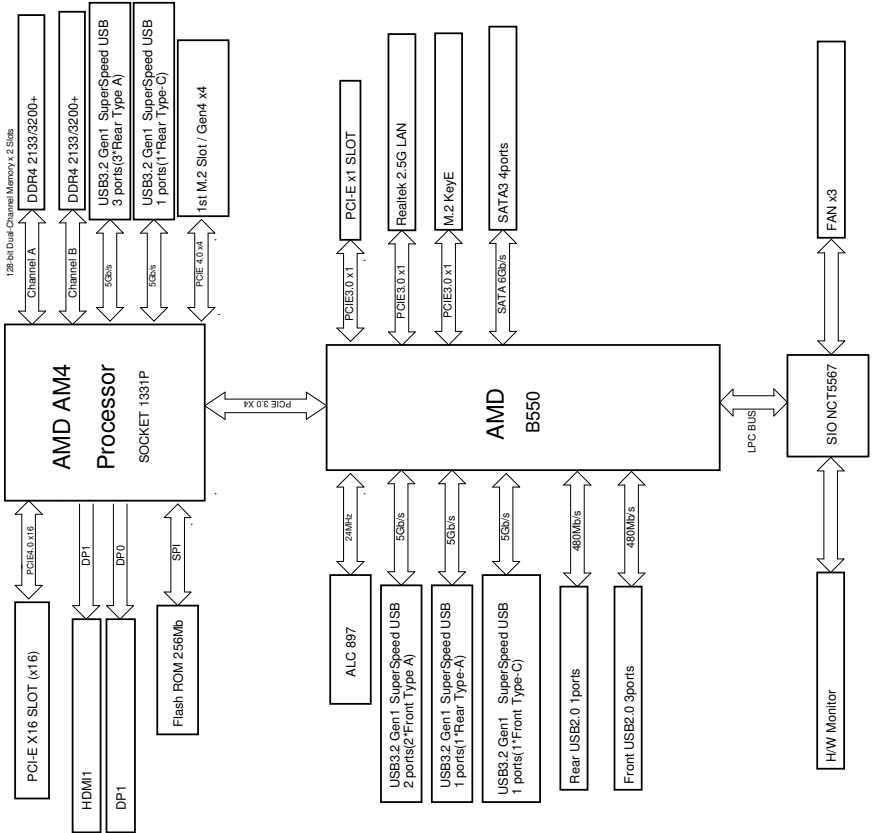

## Chapter 2 Installation

This is a Micro ATX form factor motherboard. Before you install the motherboard, study the configuration of your chassis to ensure that the motherboard fits into it.

### Pre-installation Precautions

Take note of the following precautions before you install motherboard components or change any motherboard settings.

- Make sure to unplug the power cord before installing or removing the motherboard. Failure to do so may cause physical injuries to you and damages to motherboard components.
- In order to avoid damage from static electricity to the motherboard's components, NEVER place your motherboard directly on a carpet. Also remember to use a grounded wrist strap or touch a safety grounded object before you handle the components.
- Hold components by the edges and do not touch the ICs.
- Whenever you uninstall any components, place them on a grounded anti-static pad or in the bag that comes with the components.
- When placing screws to secure the motherboard to the chassis, please do not over-tighten the screws! Doing so may damage the motherboard.

## 2.1 Installing the CPU



*Unplug all power cables before installing the CPU.*

1

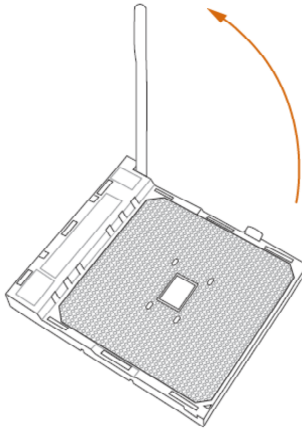

2

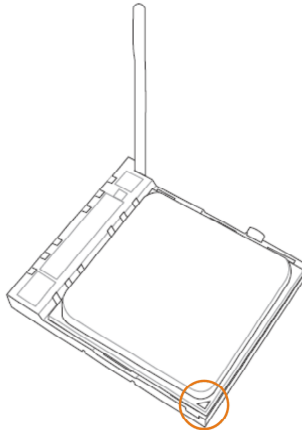

3

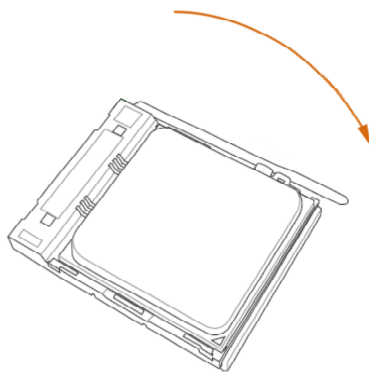

## 2.2 Installing the CPU Fan and Heatsink

After you install the CPU into this motherboard, it is necessary to install a larger heatsink and cooling fan to dissipate heat. You also need to spray thermal grease between the CPU and the heatsink to improve heat dissipation. Make sure that the CPU and the heatsink are securely fastened and in good contact with each other.



*Please turn off the power or remove the power cord before changing a CPU or heatsink.*

### Installing the CPU Box Cooler SR1

1

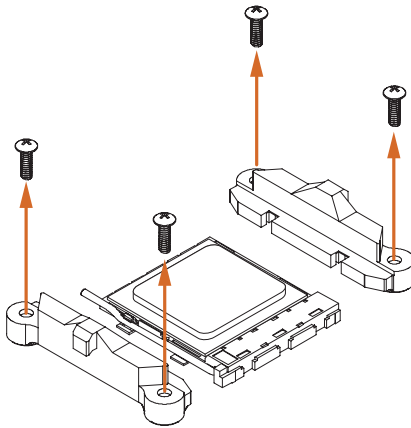

2

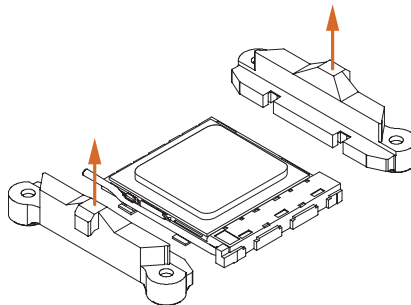

3

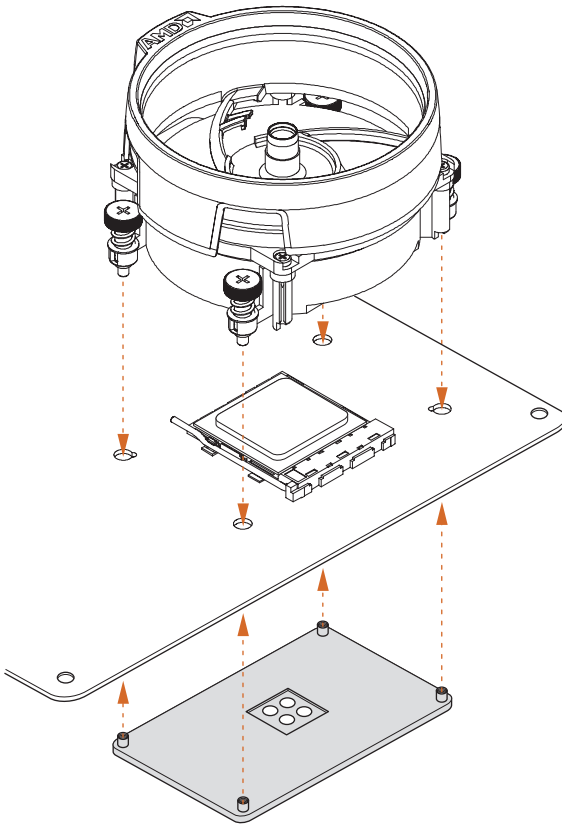

4

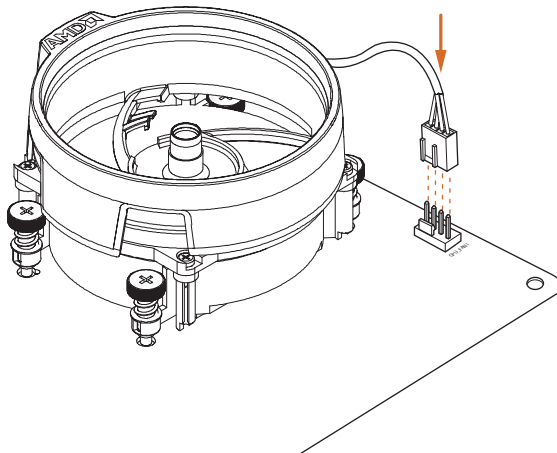

## Installing the AM4 Box Cooler SR2

1

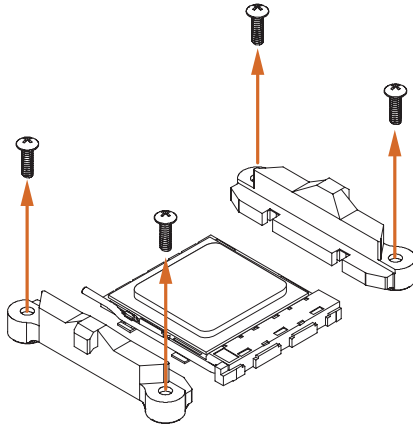

2

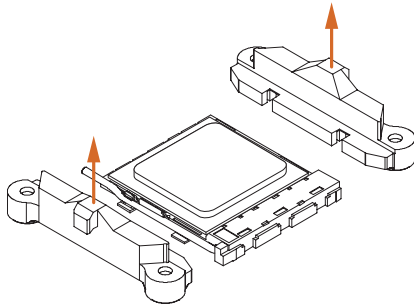

3

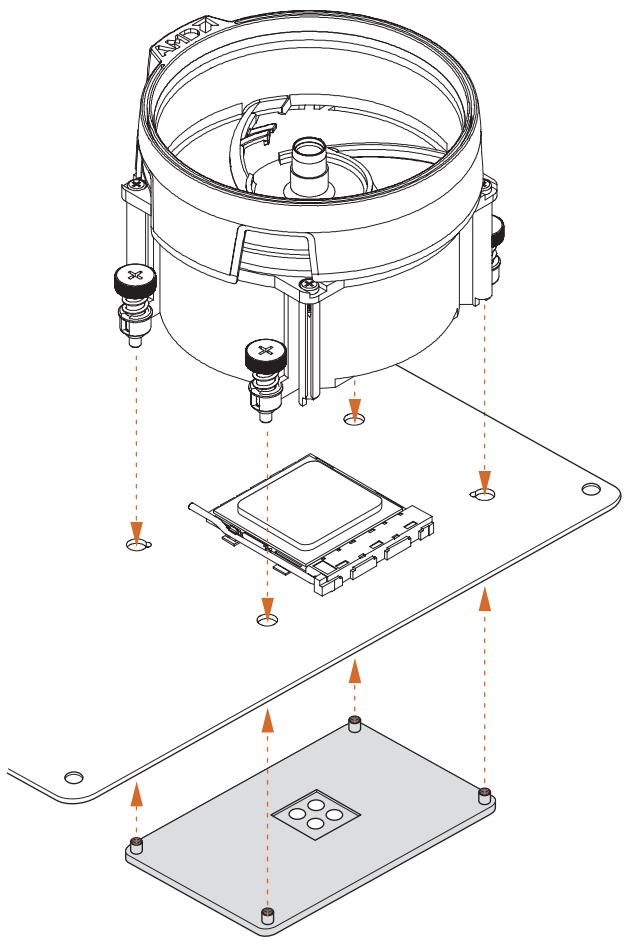

4

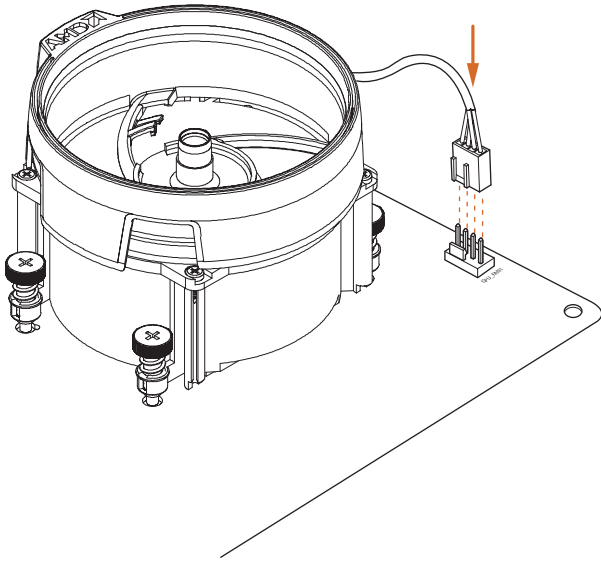

\*The diagrams shown here are for reference only. The headers might be in a different position on your motherboard.

## Installing the AM4 Box Cooler SR3

1

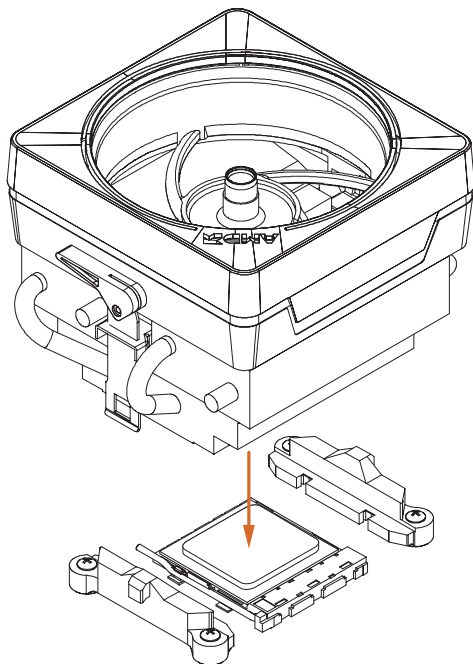

2

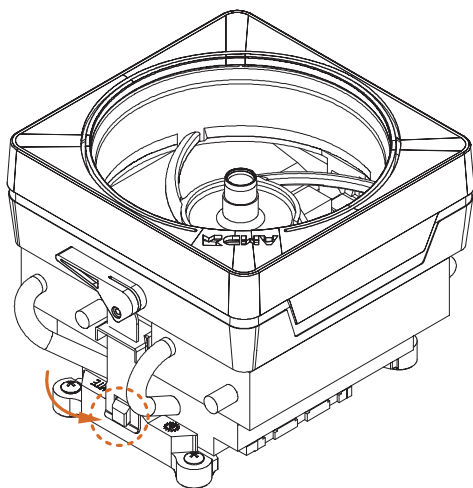

3

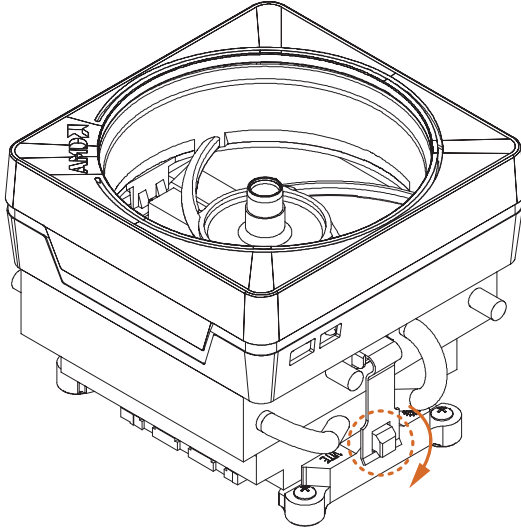

4

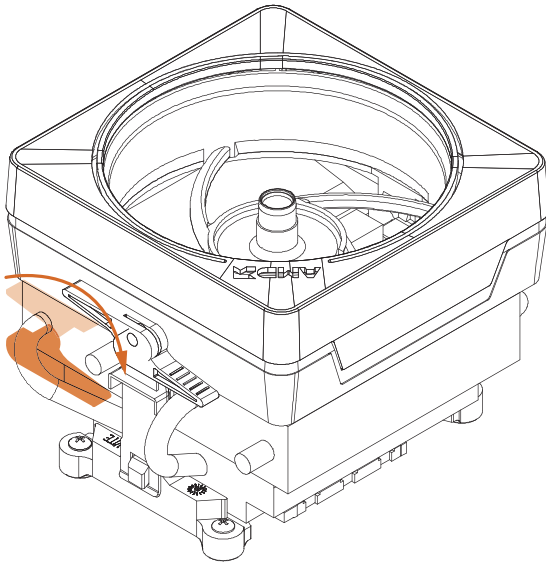

5

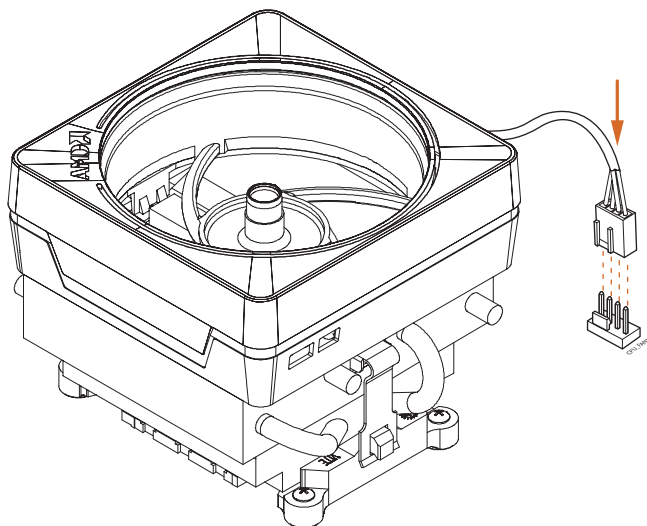

6

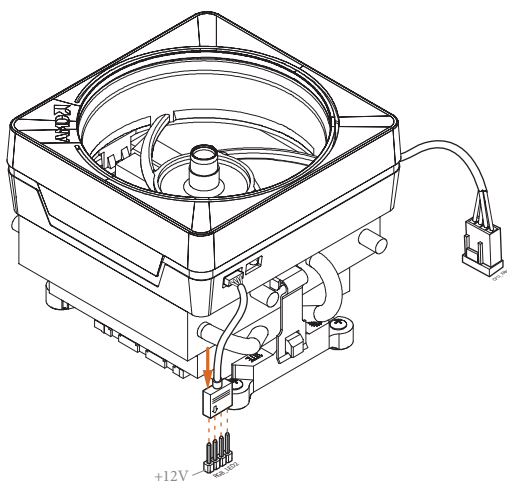

\*The diagrams shown here are for reference only. The headers might be in a different position on your motherboard.

## 2.3 Installing Memory Modules (DIMM)

This motherboard provides two 288-pin DDR4 (Double Data Rate 4) DIMM slots, and supports Dual Channel Memory Technology.



1. For dual channel configuration, you always need to install identical (the same brand, speed, size and chip-type) DDR4 DIMM pairs.
2. It is unable to activate Dual Channel Memory Technology with only one memory module installed.
3. It is not allowed to install a DDR, DDR2 or DDR3 memory module into a DDR4 slot; otherwise, this motherboard and DIMM may be damaged.

### AMD non-XMP Memory Frequency Support

Ryzen Series CPUs (Vermeer and Matisse):

UDIMM Memory Slot		Frequency
A1	B1	(Mhz)
SR	-	3200
-	SR	3200
DR	-	3200
-	DR	3200
SR	SR	3200
DR	DR	3200

Ryzen Series APUs (Cezanne and Renoir):

UDIMM Memory Slot		Frequency
A1	B1	(Mhz)
SR	-	3200
-	SR	3200
DR	-	3200
-	DR	3200
SR	SR	3200
DR	DR	3200

## Ryzen Series APUs (Picasso):

UDIMM Memory Slot		Frequency (Mhz)
A1	B1	
SR	-	2933
-	SR	2933
DR	-	2933
-	DR	2933
SR	SR	2933
DR	DR	2933

SR: Single rank DIMM, 1Rx4 or 1Rx8 on DIMM module label

DR: Dual rank DIMM, 2Rx4 or 2Rx8 on DIMM module label



The DIMM only fits in one correct orientation. It will cause permanent damage to the motherboard and the DIMM if you force the DIMM into the slot at incorrect orientation.

1

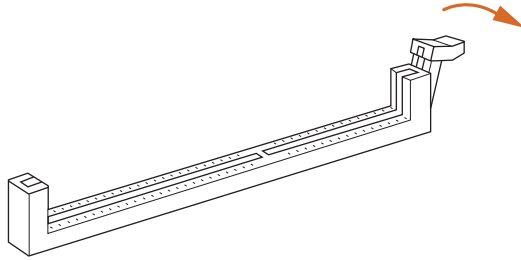

2

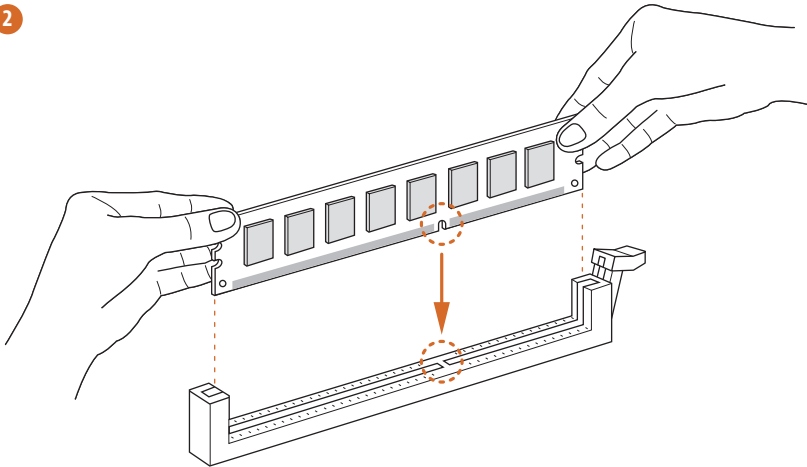

3

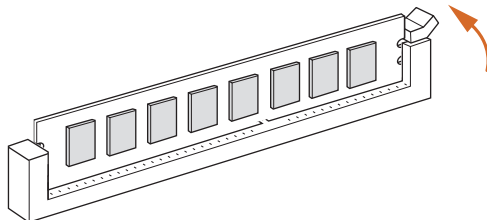

## 2.4 Connecting the Front Panel Header

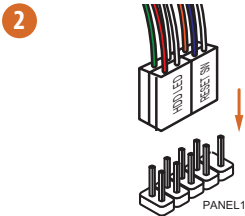
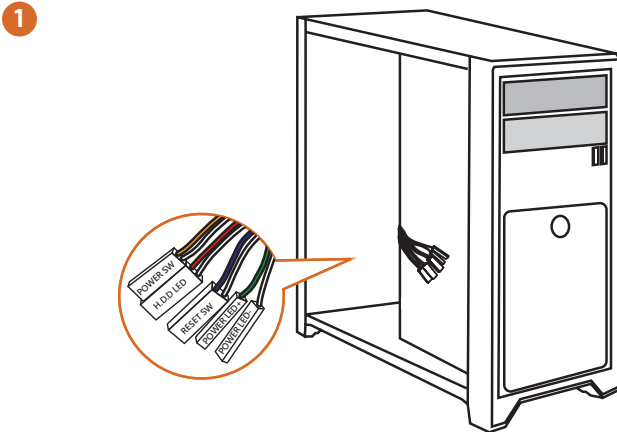

System Panel Header

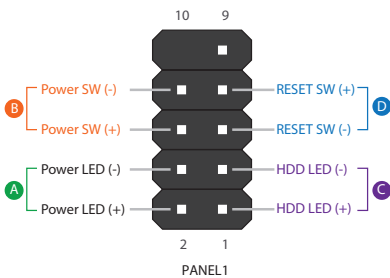

Front Panel Wires

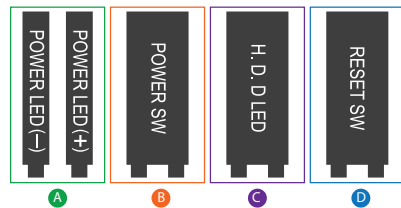

## 2.5 Installing the I/O Panel Shield

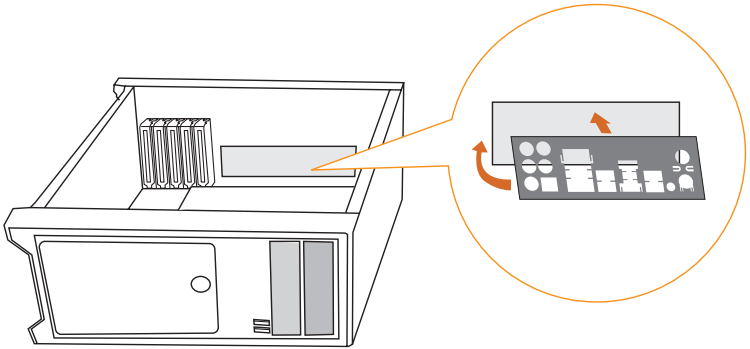

## 2.6 Installing the Motherboard

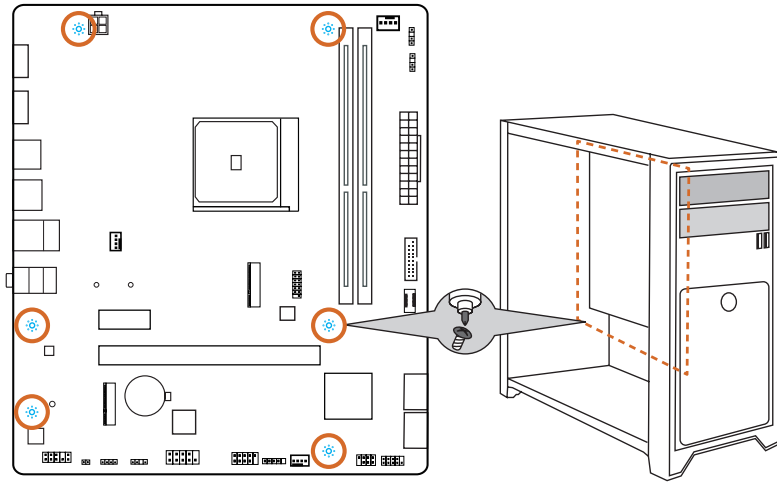

## 2.7 Installing SATA Drives

1

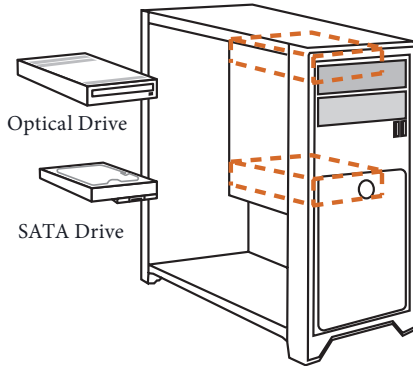

2

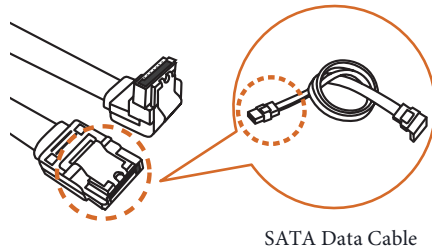

3

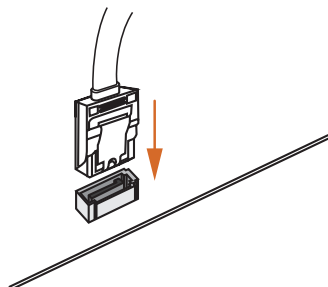

4

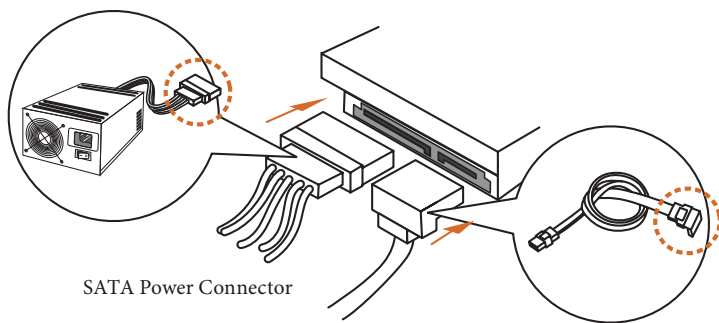

SATA Power Connector

SATA Data Connector

## 2.8 Installing a Graphics Card

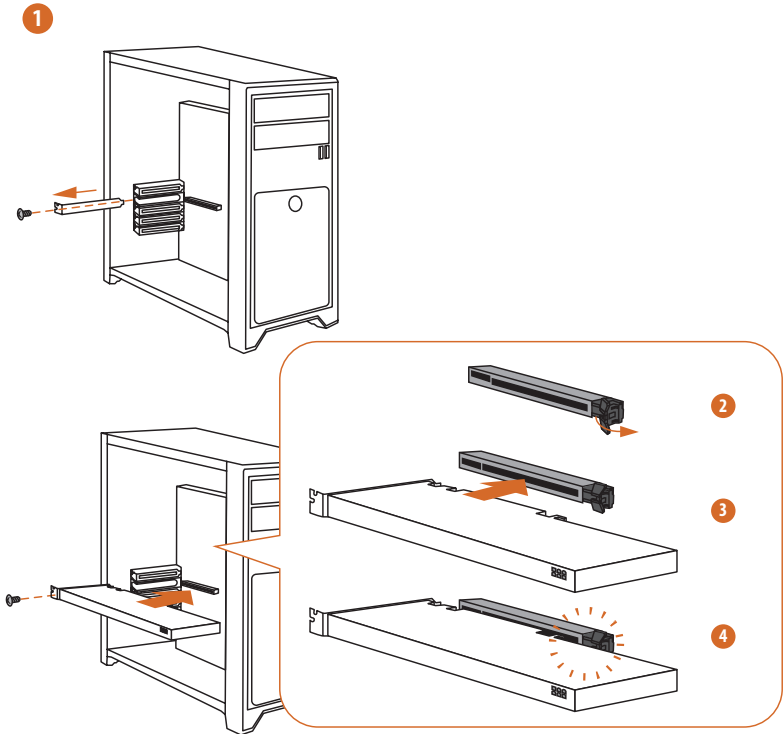

## Expansion Slots (PCIe Slots)

There are 2 PCI Express slots on the motherboard.



*Before installing an expansion card, please make sure that the power supply is switched off or the power cord is unplugged. Please read the documentation of the expansion card and make necessary hardware settings for the card before you start the installation.*

### **PCIe slots:**

PCIE1 (PCIe 3.0 x1 slot) is used for PCI Express x1 lane width cards.

PCIE2 (PCIe 4.0 x16 slot) is used for PCI Express x16 lane width graphics cards.\*

\* When using certain NVIDIA RTX 4060 graphics cards on this motherboard, PCIE2 will run at PCIe 3.0 mode.

## 2.9 Connecting Peripheral Devices

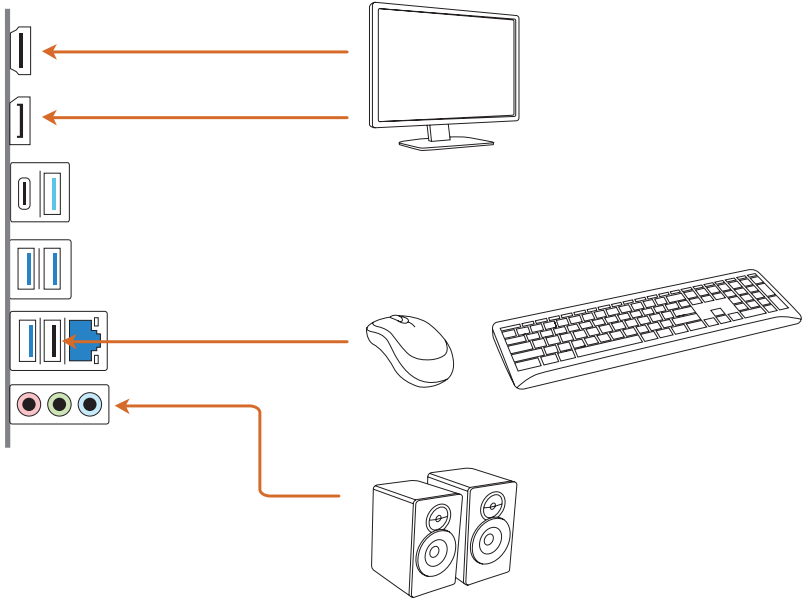

## 2.10 Connecting the Power Connectors

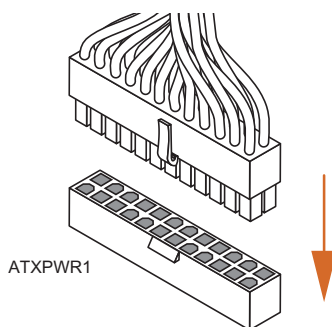
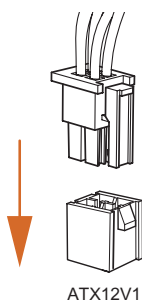
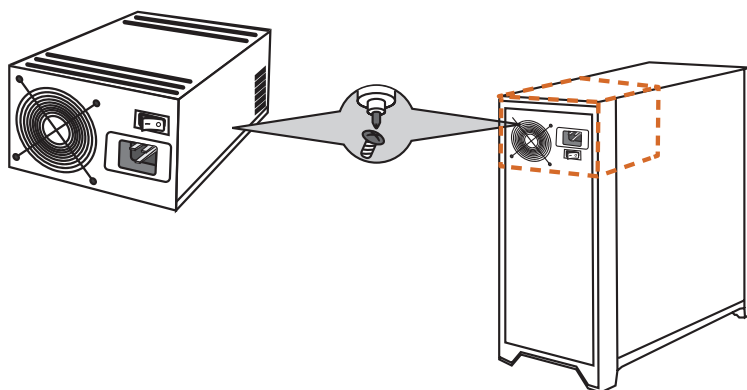

## 2.11 Power On

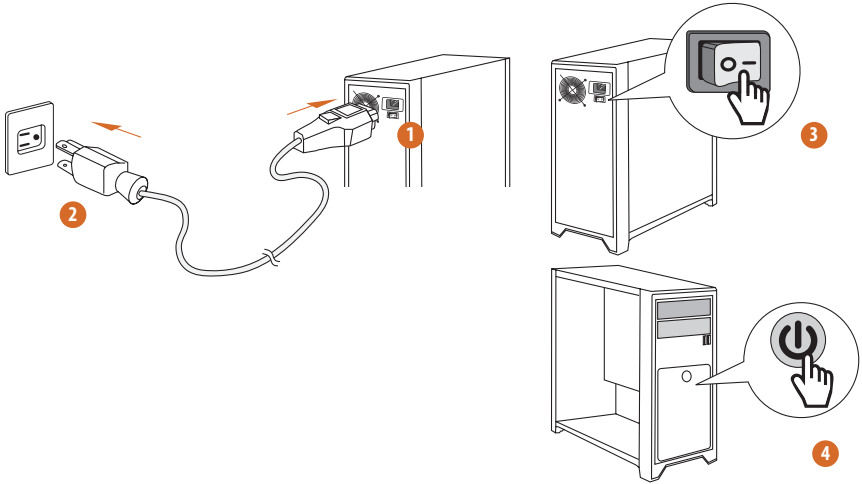

## 2.12 Jumpers Setup

The illustration shows how jumpers are setup. When the jumper cap is placed on the pins, the jumper is “Short”. If no jumper cap is placed on the pins, the jumper is “Open”.

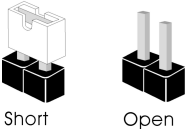

### Clear CMOS Jumper

(CLR\_CMOS1) (see p.6, No. 20)

CLR\_CMOS1 allows you to clear the data in CMOS. The data in CMOS includes system setup information such as system password, date, time, and system setup parameters. To clear and reset the system parameters to default setup, please turn off the computer and unplug the power cord, then use a jumper cap to short the pins on CLR\_CMOS1 for 3 seconds. Please remember to remove the jumper cap after clearing the CMOS. If you need to clear the CMOS when you just finish updating the BIOS, you must boot up the system first, and then shut it down before you do the clear-CMOS action.

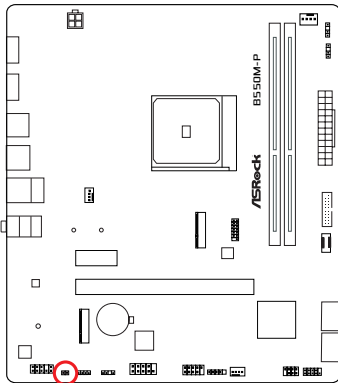

CLR\_CMOS1



2-pin Jumper

Short: Clear CMOS

Open: Default

## 2.13 Onboard Headers and Connectors



Onboard headers and connectors are NOT jumpers. Do NOT place jumper caps over these headers and connectors. Placing jumper caps over the headers and connectors will cause permanent damage to the motherboard.

### System Panel Header

(9-pin PANEL1) (see p.6, No. 12)

Connect the power button, reset button and system status indicator on the chassis to this header according to the pin assignments below. Note the positive and negative pins before connecting the cables.

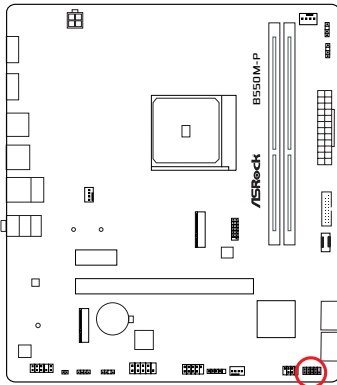

PANEL1

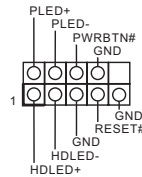

#### **PWRBTN (Power Button):**

Connect to the power button on the chassis front panel. You may configure the way to turn off your system using the power button.

#### **RESET (Reset Button):**

Connect to the reset button on the chassis front panel. Press the reset button to restart the computer if the computer freezes and fails to perform a normal restart.

#### **PLED (System Power LED):**

Connect to the power status indicator on the chassis front panel. The LED is on when the system is operating. The LED keeps blinking when the system is in S1/S3 sleep state. The LED is off when the system is in S4 sleep state or powered off (S5).

#### **HDLED (Hard Drive Activity LED):**

Connect to the hard drive activity LED on the chassis front panel. The LED is on when the hard drive is reading or writing data.

The front panel design may differ by chassis. A front panel module mainly consists of power button, reset button, power LED, hard drive activity LED, speaker and etc. When connecting your chassis front panel module to this header, make sure the wire assignments and the pin assignments are matched correctly.

### Chassis Intrusion and Speaker Header (7-pin SPK\_C11) (see p.6, No. 13)

Please connect the chassis power LED and the chassis speaker to this header.

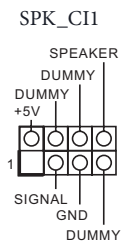
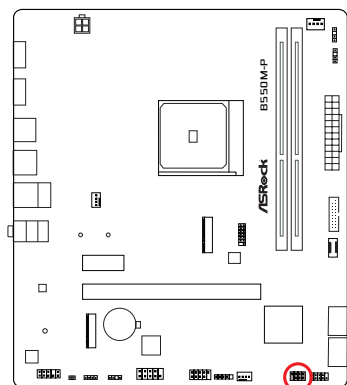

## Serial ATA3 Connectors

### Right Angle:

(SATA3\_1) (see p.6, No. 11)(Upper)

(SATA3\_2) (see p.6, No. 11)(Lower)

(SATA3\_3) (see p.6, No. 10)(Upper)

(SATA3\_4) (see p.6, No. 10)(Lower)

These four SATA3 connectors support SATA data cables for internal storage devices with up to 6.0 Gb/s data transfer rate.

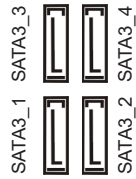
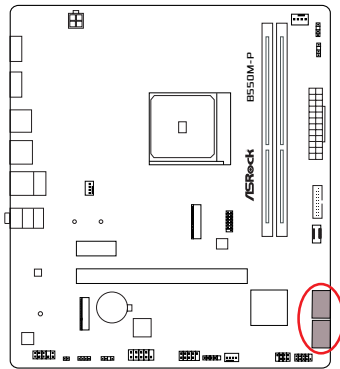



### USB 3.2 Gen1 Header

(19-pin USB32\_5\_6) (see p.6, No. 7)

There is one header on this motherboard. This USB 3.2 Gen1 header can support two ports.

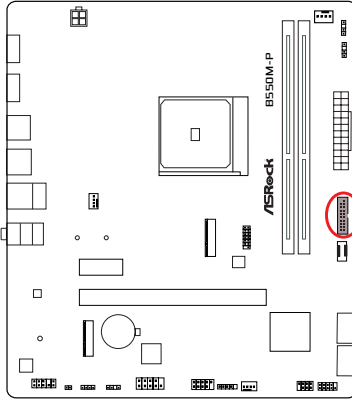

USB32\_4\_5

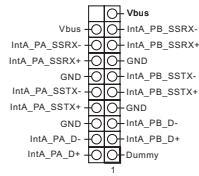

### Front Panel Type C USB 3.2 Gen1 Header

(20-pin USB32\_TC2) (see p.6, No. 9)

There is one Front Panel Type C USB 3.2 Gen1 Header on this motherboard. This header is used for connecting a USB 3.2 Gen1 module for additional USB 3.2 Gen1 ports.

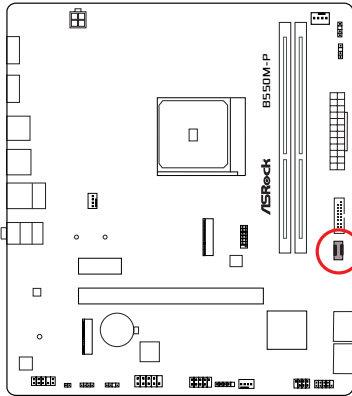

USB32\_TC2

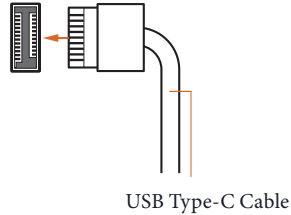

### Front Panel Audio Header

(9-pin HD\_AUDIO1) (see p.6, No. 21)

This header is for connecting audio devices to the front audio panel.

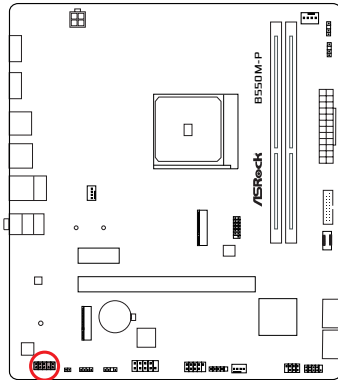

### HD\_AUDIO1

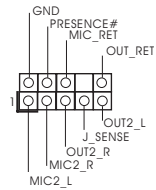

*High Definition Audio supports Jack Sensing, but the panel wire on the chassis must support HDA to function correctly. Please follow the instructions in our manual and chassis manual to install your system.*

## Chassis Fan Connectors

(4-pin CHA\_FAN1) (see p.6, No. 22)

(4-pin CHA\_FAN2) (see p.6, No. 14)

These headers allow you to connect Case or Radiator fans. If you plan to connect a 3-pin fan, please connect it to Pin 1-3.

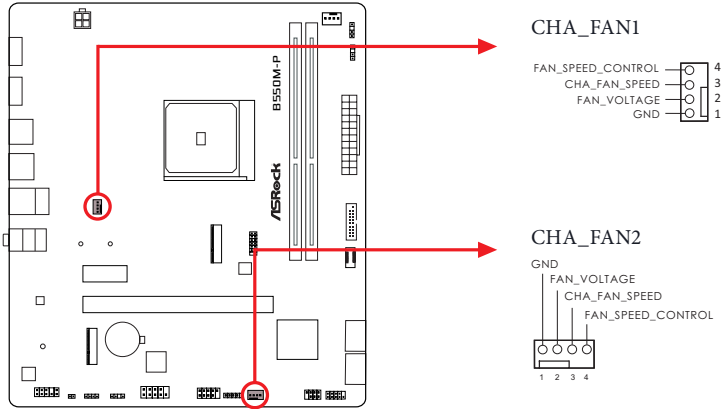

### CPU Fan Connector

(4-pin CPU\_FAN1) (see p.6, No. 3)

This header allows you to connect CPU fan. If you plan to connect a 3-pin fan, please connect it to Pin 1-3.

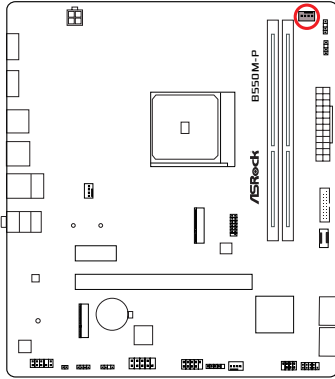

CPU\_FAN1

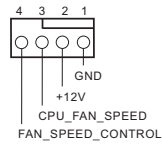

### ATX Power Connector

(24-pin ATXPWR1) (see p.6, No. 6)

This motherboard provides a 24-pin ATX power connector. To use a 20-pin ATX power supply, please plug it along Pin 1 and Pin 13.

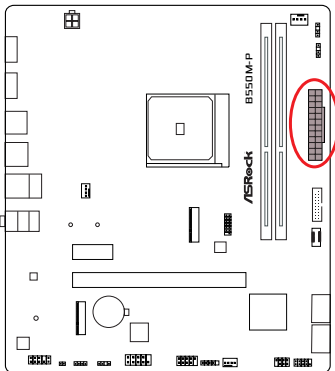

ATXPWR1

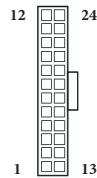

ATX 12V Power Connector  
(4-pin ATX12V1) (see p.6, No. 1)

Please connect an ATX 12V power supply to this connector.

\*The power supply plug fits into this connector in only one orientation.

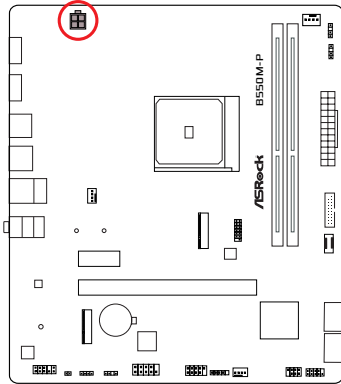

ATX12V1



Serial Port Header  
(9-pin COM1) (see p.6, No. 17)

This COM1 header supports a serial port module.

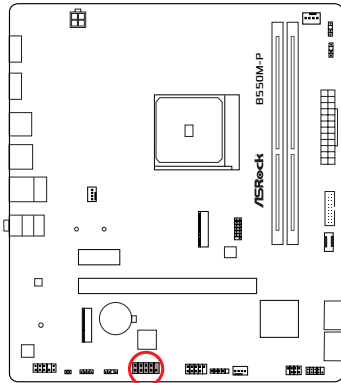

COM1

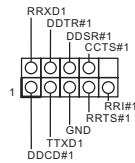

## SPI TPM Header

(13-pin SPI\_TPM\_J1) (see p.6, No. 8)

This connector supports SPI Trusted Platform Module (TPM) system, which can securely store keys, digital certificates, passwords, and data. A TPM system also helps enhance network security, protects digital identities, and ensures platform integrity.

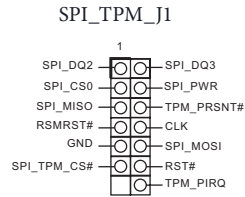
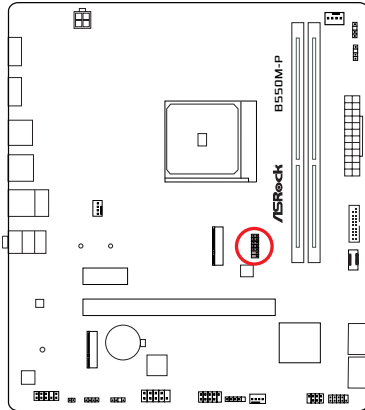

## RGB LED Header

(4-pin RGB\_LED1) (see p.6, No. 19)

This RGB header is used to connect RGB LED extension cable which allow users to choose from various LED lighting effects.

**Caution: Never install the RGB LED cable in the wrong orientation; otherwise, the cable may be damaged.**

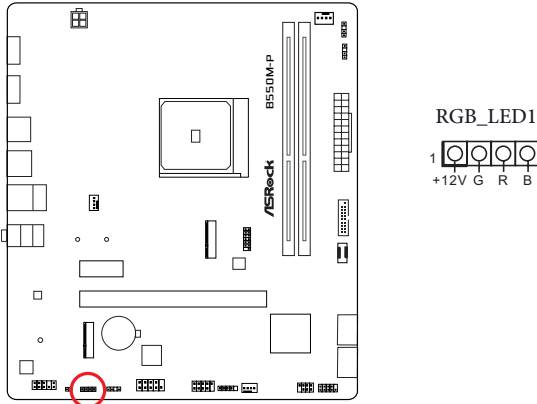

Connect your RGB LED strip to the **RGB LED Header (RGB\_LED1)** on the motherboard.

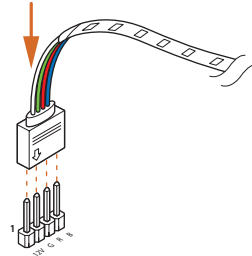

1. Never install the RGB LED cable in the wrong orientation; otherwise, the cable may be damaged.
2. Before installing or removing your RGB LED cable, please power off your system and unplug the power cord from the power supply. Failure to do so may cause damages to motherboard components.



1. Please note that the RGB LED strip does not come with the package.
2. The RGB LED header supports standard 5050 RGB LED strip (12V/G/R/B), with a maximum power rating of 3A (12V) and length within 2 meters.

### Addressable LED Headers

(3-pin ADDR\_LED1) (see p.6, No. 4)

(3-pin ADDR\_LED2) (see p.6, No. 5)

(3-pin ADDR\_LED3) (see p.6, No. 18)

These headers are used to connect Addressable LED extension cables which allow users to choose from various LED lighting effects.

**Caution: Never install the Addressable LED cable in the wrong orientation; otherwise, the cable may be damaged.**

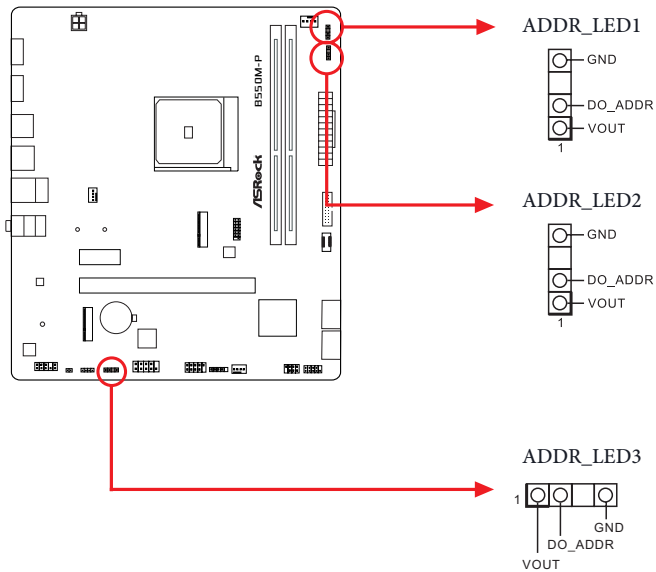

Connect your Addressable RGB LED strips to the **Addressable LED Headers (ADDR\_LED1 / ADDR\_LED2 / ADDR\_LED3)** on the motherboard.

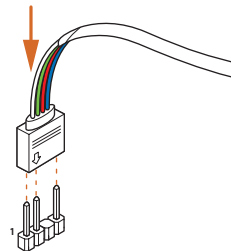



1. *Never install the Addressable LED cable in the wrong orientation; otherwise, the cable may be damaged.*
2. *Before installing or removing your Addressable LED cable, please power off your system and unplug the power cord from the power supply. Failure to do so may cause damages to motherboard components.*



1. *Please note that the Addressable LED strips do not come with the package.*
2. *The Addressable LED header supports WS2812B addressable RGB LED strip (5V/Data/GND), with a maximum power rating of 3A (5V) and length within 2 meters.*

## 2.14 M.2 WiFi/BT Module Installation Guide

The M.2 is a small size and versatile card edge connector that aims to replace mPCIe and mSATA. The M.2 Socket (Key E) supports type 2230 WiFi/BT module.

\* The M.2 socket does not support SATA M.2 SSDs.

### Installing the WiFi/BT module

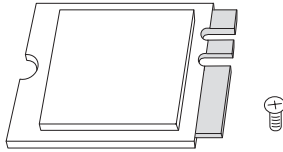

#### Step 1

Prepare a type 2230 WiFi/BT module and the screw.

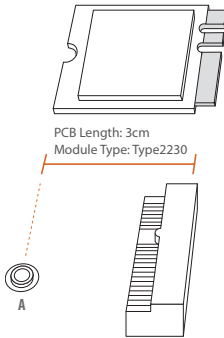

#### Step 2

Find the nut location to be used.

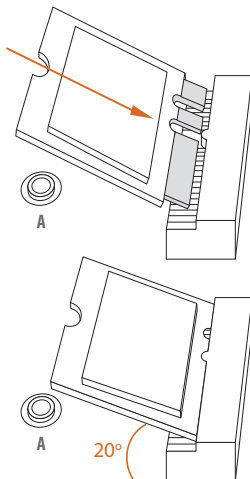

#### Step 3

Gently insert the WiFi/BT module into the M.2 slot. Please be aware that the module only fits in one orientation.

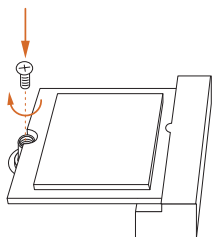

#### **Step 4**

Tighten the screw with a screwdriver to secure the module into place. Please do not overtighten the screw as this might damage the module.

## 2.15 M.2 SSD Installation Guide (M2\_1)

The M.2 is a small size and versatile card edge connector that aims to replace mPCIe and mSATA. The Hyper M.2 Socket (M2\_1, Key M) supports type 2260/2280 SATA3 6.0 Gb/s & PCIe Gen4x4 (64 Gb/s) modes.

\* NVMe SSD is not supported with AMD Athlon™ 3000G Processors

### Installing the M.2 SSD

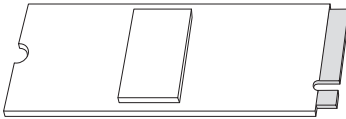

#### Step 1

Prepare a M.2 SSD and the screw.

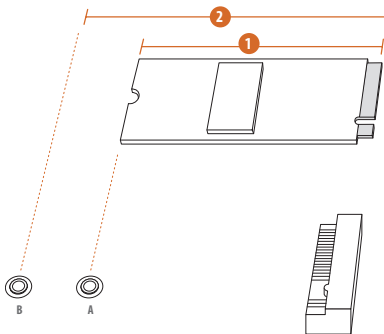

#### Step 2

Depending on the PCB type and length of your M.2 SSD, find the corresponding nut location to be used.

No.	1	2
Nut Location	A	B
PCB Length	6cm	8cm
Module Type	Type2260	Type 2280

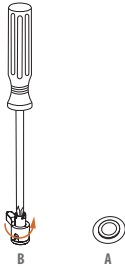

### Step 3

Use a screwdriver to remove the standoff.

*Skip Step 3 if your M.2 SSD is Type 2280.*

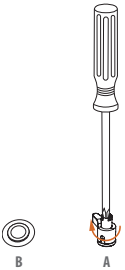

### Step 4

Peel off the yellow protective film on the nut to be used. Tighten the standoff into the desired nut location on the motherboard with a screwdriver.

*Skip Step 4 if your M.2 SSD is Type 2280.*

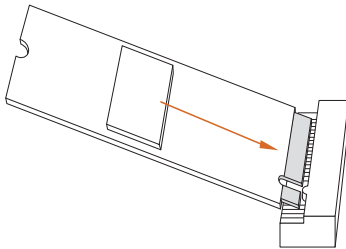
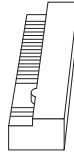

### Step 5

Align and gently insert the M.2 SSD into the M.2 slot. Please be aware that the M.2 SSD only fits in one orientation.

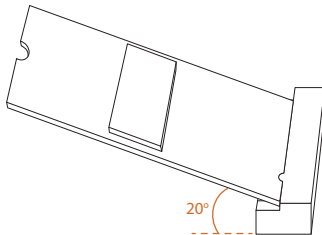

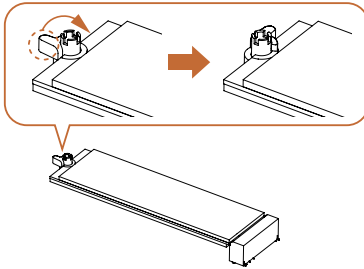
**Step 6**

Ensure that the notch at the end of the M.2 SSD aligns with the nut. Then secure the M.2 SSD by turning the nut lock clockwise to its locked position.

For the latest updates of M.2 SSD support list, please visit our website for details: <http://www.asrock.com>

Version 1.0

Published April 2026

Copyright©2026 ASRock INC. All rights reserved.

### Copyright Notice:

No part of this documentation may be reproduced, transcribed, transmitted, or translated in any language, in any form or by any means, except duplication of documentation by the purchaser for backup purpose, without written consent of ASRock Inc.

Products and corporate names appearing in this documentation may or may not be registered trademarks or copyrights of their respective companies, and are used only for identification or explanation and to the owners' benefit, without intent to infringe.

### Disclaimer:

Specifications and information contained in this documentation are furnished for informational use only and subject to change without notice, and should not be constructed as a commitment by ASRock. ASRock assumes no responsibility for any errors or omissions that may appear in this documentation.

To the extent permitted by law, with respect to the contents of this documentation, ASRock does not provide warranty of any kind, either expressed or implied, including but not limited to the implied warranties or conditions of merchantability or fitness for a particular purpose. In no event shall ASRock, its directors, officers, employees, or agents be liable for any indirect, special, incidental, or consequential damages (including damages for loss of profits, loss of business, loss of data, interruption of business and the like), even if ASRock has been advised of the possibility of such damages arising from any defect or error in the documentation or product.

## FCC Compliance Statement



This device complies with Part 15 of the FCC Rules. Operation is subject to the following two conditions:

- (1) this device may not cause harmful interference, and
- (2) this device must accept any interference received, including interference that may cause undesired operation.

This equipment has been tested and found to comply with the limits for a Class B digital device, pursuant to part 15 of the FCC Rules. These limits are designed to provide reasonable protection against harmful interference in a residential installation. This equipment generates, uses and can radiate radio frequency energy and, if not installed and used in accordance with the instructions, may cause harmful interference to radio communications. However, there is no guarantee that interference will not occur in a particular installation. If this equipment does cause harmful interference to radio or television reception, which can be determined by turning the equipment off and on, the user is encouraged to try to correct the interference by one or more of the following measures:

- Reorient or relocate the receiving antenna.
- Increase the separation between the equipment and receiver.
- Connect the equipment into an outlet on a circuit different from that to which the receiver is connected.
- Consult the dealer or an experienced radio/TV technician for help.

## Button Battery Safety Notice

### **WARNING**

- **INGESTION HAZARD:** This product contains a button cell or coin battery.
- **DEATH** or serious injury can occur if ingested.
- A swallowed button cell or coin battery can cause **Internal Chemical Burns** in as little as **2 hours**.
- **KEEP** new and used batteries **OUT OF REACH** of **CHILDREN**
- **Seek immediate medical attention** if a battery is suspected to be swallowed or inserted inside any part of the body.



- Remove and immediately recycle or dispose of used batteries according to local regulations and keep away from children. Do NOT dispose of batteries in household trash or incinerate.
- Even used batteries may cause severe injury or death.
- Call a local poison control center for treatment information.
- Battery type: CR2032
- Battery voltage: 3V
- Non-rechargeable batteries are not to be recharged.
- Do not force discharge, recharge, disassemble, heat above (manufacturer's specified temperature rating) or incinerate. Doing so may result in injury due to venting, leakage or explosion resulting in chemical burns.
- This product contains an irreplaceable battery.
- This icon indicates that a swallowed button battery can cause serious injury or death. Please keep batteries out of sight or reach of children.

## CALIFORNIA, USA ONLY

The Lithium battery adopted on this motherboard contains Perchlorate, a toxic substance controlled in Perchlorate Best Management Practices (BMP) regulations passed by the California Legislature. When you discard the Lithium battery in California, USA, please follow the related regulations in advance.

“Perchlorate Material-special handling may apply, see [www.dtsc.ca.gov/hazardouswaste/perchlorate](http://www.dtsc.ca.gov/hazardouswaste/perchlorate)”

## CALIFORNIA, USA ONLY



WARNING: Cancer and Reproductive Harm  
[www.P65Warnings.ca.gov](http://www.P65Warnings.ca.gov)

## CE Conformity



ASRock INC. hereby declares that this device is in compliance with the essential requirements and other relevant provisions of related Directives. Full text of EU declaration of conformity is available at: <http://www.asrock.com>

ASRock follows the green design concept to design and manufacture our products, and makes sure that each stage of the product life cycle of ASRock product is in line with global environmental regulations. In addition, ASRock disclose the relevant information based on regulation requirements.

Please refer to <https://www.asrock.com/general/about.asp?cat=Responsibility> for information disclosure based on regulation requirements ASRock is complied with.

## UKCA Conformity



ASRock INC. hereby declares that this device is in compliance with the essential requirements and other relevant provisions of related UKCA Directives. Full text of UKCA declaration of conformity is available at: <http://www.asrock.com>

## Consumer Limited Warranty - Australia

Our goods come with guarantees that cannot be excluded under the Australian Consumer Law. You are entitled to a replacement or refund for a major failure and compensation for any other reasonably foreseeable loss or damage caused by our goods. You are also entitled to have the goods repaired or replaced if the goods fail to be of acceptable quality and the failure does not amount to a major failure. If you require assistance please call ASRock Tel : +886-2-28965588 ext.123 (Standard International call charges apply)



### WARNING

THIS PRODUCT CONTAINS A BUTTOON BATTERY

If swallowed, a button battery can cause serious injury or death.  
Please keep batteries out of sight or reach of children.

## Proper Disposal



DO NOT throw the motherboard in municipal waste. This product has been designed to enable proper reuse of parts and recycling. This symbol of the crossed out wheeled bin indicates that the product (electrical and electronic equipment) should not be placed in municipal waste. Check local regulations for disposal of electronic products.

## Class B ITE

この装置は、クラス B 情報技術装置です。この装置は、家庭環境で使用することを目的としていますが、この装置がラジオやテレビジョン受信機に近接して使用されると、受信障害を引き起こすことがあります。取扱説明書に従って正しい取り扱いをして下さい。

## Trademark Information

The terms HDMI® and HDMI High-Definition Multimedia Interface, and the HDMI logo are trademarks or registered trademarks of HDMI Licensing LLC in the United States and other countries.



## BSMI 限用物質及元素清單

單元	限用物質及其化學符號					
	鉛 (Pb)	鎘 (Cd)	汞 (Hg)	六價鉻 (Cr <sup>+6</sup> )	多溴聯苯 (PBB)	多溴聯苯醚 (PBDE)
電路板	○	○	○	○	○	○
電子元件	-	○	○	○	○	○
線材	-	○	○	○	○	○
配件	-	○	○	○	○	○

備考 1. “超出 0.1 wt %” 及 “超出 0.01 wt %” 係指限用物質之百分比含量超出百分比含量基準值。

備考 2. “○” 係指該項限用物質之百分比含量未超出百分比含量基準值。

備考 3. “-” 係指該項限用物質為排除項目。

## China RoHS

### 电子信息产品污染控制标示

依据中国发布的「电子信息产品污染控制管理办法」及 SJ/T 11364-2014「电子信息产品污染控制标示要求」，电子信息产品应进行标示，藉以向消费者揭露产品中含有的有毒有害物质或元素不致发生外泄或突变从而对环境造成污染或对人身、财产造成严重损害的期限。依上述规定，您可于本产品之印刷电路板上看见图一之标示。图一中之数字为产品之环保使用期限。由此可知此主板之环保使用期限为 10 年。



图一

### 有毒有害物质或元素的名称及含量说明

若您欲了解此产品的有毒有害物质或元素的名称及含量说明，请参照以下表格及说明。

部件名称	有害物质或元素					
	铅 (Pb)	镉 (Cd)	汞 (Hg)	六价铬 (Cr(VI))	多溴联苯 (PBB)	多溴二苯醚 (PBDE)
印刷电路板及电子组件	X	O	O	O	O	O
外部信号连接头及线材	X	O	O	O	O	O

以上表格依据 SJ/T 11364-2014 的规定编制。  
O: 表示该有害物质在该部件所有均质材料中的含量均在 GB/T 26572 规定的限量要求以下。  
X: 表示该有害物质至少在该部件的某一均质材料中的含量超出 GB/T 26572 规定的限量要求。  
备注：此产品所标示之环保使用年限，系指在一般正常使用状况下。